



Heating and Air Conditioning

TECHNICAL GUIDE

R-22 SPLIT-SYSTEM HEAT PUMPS

13 SEER – R-22

MODELS:

E*RD018 THRU 060

(1.5 THRU 5 NOMINAL TONS, 1 PHASE)

E*RD030 THRU 060

(2.5 THRU 5 NOMINAL TONS, 3 PHASE)



CERTIFICATION APPLIES ONLY
WHEN THE COMPLETE
SYSTEM IS LISTED
WITH ARI.



ISO 9001
Certified Quality
Management System

Due to continuous product improvement, specifications are subject to change without notice.

Visit us on the web at www.york.com for the most up-to-date technical information.

Additional rating information can be found at www.ari.org/ari directory

DESCRIPTION

The 13 SEER series heat pumps are designed for use with a variety of UPG evaporator sections to suit any application need. A full line of matching Add-On Coils are available for use with upflow, downflow or horizontal furnaces. Matching Air Handlers are also available for upflow, downflow or horizontal installation to provide a complete system. Electric heat may be installed in air handlers. All units are factory charged to assure easy installation.

WARRANTY

Single Phase Units:

5-year limited parts warranty.

5-year limited compressor warranty.

Three Phase Units:

1-year limited parts warranty.

5-year limited compressor warranty.

FEATURES

- **DURABLE CONSTRUCTION** - The outdoor unit is constructed of pre-painted steel that offers tough protection against corrosion and resists fading when exposed to sunlight. Drain holes are incorporated into the base pan to permit free drainage of moisture.
- **QUALITY COILS** - The coil is constructed of enhanced copper tube and aluminum fins.
- **COIL PROTECTION** - Coils are protected from damage by a polymer mesh applied between the coil face, and a PVC coated steel coil guard.
- **PROTECTED COMPRESSOR** - The hermetic compressor is internally protected against high pressure and temperature by the simultaneous operation of a high pressure relief valve and temperature sensors which stop the compressor if operating temperatures go too high. Both protectors reset automatically. A discharge line solid core filter drier further protects the compressor.
- **Complete System Control** - These heat pumps utilize the unique microprocessor defrost control system to provide optimal comfort and to monitor the overall system for reliable operation. The defrost control system continuously monitors the space environment to maintain optimum efficiency. It initiates defrost only when necessary to further reduce heating costs and improve reliability. In the event improper operating conditions occur, the control will automatically shut the system down to extend the life of the heat pump. Rapid cycling is prevented by use of an internal anti-recycle timer.
- **LOW OPERATING SOUND LEVEL** - The compressor is mounted on rubber isolators to reduce operating sounds. The slow moving condenser fan keeps air turbulence and sound to a low level.
- **EASY ACCESS** - Removable panel affords accessibility to the electrical box.
- **FULLY CHARGED AND FACTORY WIRED** - to simply installation and reduce labor costs. Only power supply and control wiring and refrigerant lines must be connected. All models are sweat connect with reusable service valves.
- **Factory tested** - to verify system operation and control functioning before shipment.
- **U.L. and C.U.L. listed** - approved for outdoor application.

Certified in accordance with the Unitary Small Equipment certification program, which is based on ARI Standard 210/240.

PHYSICAL AND ELECTRICAL DATA - 1 PHASE

MODEL		E1RD018S06	E1RD024S06	E1RD030S06	E1RD036S06	E1RD042S06	E1RD048S06	E1RD060S06
Unit Supply Voltage		208-230V, 1 ϕ , 60Hz						
Normal Voltage Range ¹		187 to 252						
Minimum Circuit Ampacity		9.9	15.0	16.9	19.8	25.0	32.7	37.8
Max. Overcurrent Device Amps ²		15	25	25	30	40	50	60
Min. Overcurrent Device Amps ³		15	20	20	20	30	35	40
Compressor Type ⁴		Recip	Recip	Recip	Recip	Recip	Scroll ^D	Scroll ^D
Compressor Amps	Rated Load	7.5	10.7	12.4	14.6	18.8	25.0	29.1
	Locked Rotor	41	44	60	78	78	115	150
Crankcase Heater		Yes	Yes	Yes	Yes	Yes	No	No
Fan Motor Amps	Rated Load	0.5	1.5	1.5	1.5	1.5	1.5	1.5
Fan Diameter Inches		22	22	22	22	22	24	24
Fan Motor	Rated HP	1/15	1/4	1/4	1/4	1/4	1/4	1/4
	Nominal RPM	850	850	850	850	850	850	850
	Nominal CFM	2,000	3,250	3,450	3,500	3,500	3,400	3,500
Coil	Face Area Sq. Ft.	15.72	18.34	20.96	23.58	23.58	24.00	27.00
	Rows Deep	1	1	1	1	1	2	2
	Fin / Inches	22	22	22	22	22	18	18
Liquid Line Set OD (Field Installed)		3/8	3/8	3/8	3/8	3/8	3/8	3/8
Vapor Line Set OD (Field Installed)		3/4	3/4	7/8	7/8	7/8	7/8	1-1/8
Unit Charge (Lbs. - Oz.) ⁵		7 - 1	6 - 6	8 - 7	8 - 7	8 - 7	12 - 8	16 - 7
Charge Per Foot, Oz.		0.68	0.68	0.70	0.70	0.70	0.70	0.76
Operating Weight Lbs.		172	184	196	208	208	250	294

1. Rated in accordance with ARI Standard 110, utilization range "A".
2. Dual element fuses or HACR circuit breaker. Maximum allowable overcurrent protection.
3. Dual element fuses or HACR circuit breaker. Minimum recommended overcurrent protection.
4. All scrolls listed with a superscript "D" are Danfoss scrolls. All scrolls listed with a superscript "C" are Copeland scrolls.
5. The Unit Charge is correct for the outdoor unit, matched indoor coil and 15 feet of refrigerant tubing. For tubing lengths other than 15 feet, add or subtract the amount of refrigerant, using the difference in length multiplied by the per foot value.

All dimensions are in inches. They are subject to change without notice. Certified dimensions will be provided upon request.

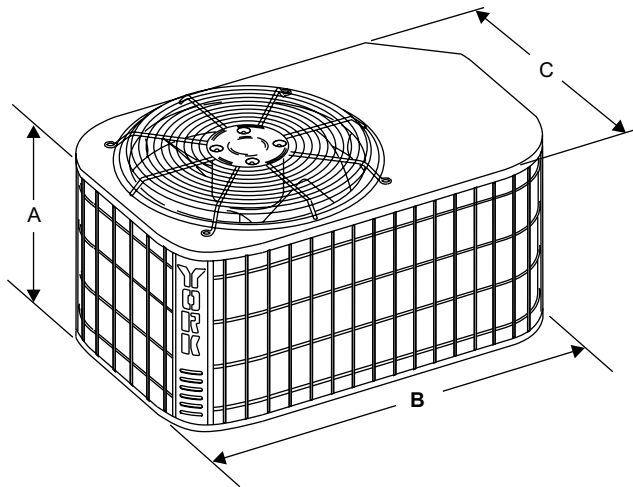

Unit Model	Dimensions (Inches)			Refrigerant Connection Service Valve Size	
	A ¹	B	C	Liquid	Vapor
018	27	37	27	3/8"	3/4"
024	31	37	27		
030	35	37	27		
036	39	37	27		7/8"
042	39	37	27		
048	34	43	32		
060	38	43	32		
					7/8**

1. Including Fan Guard.
- * Adapter fitting required for 1-1/8" line set.

Additional R-22 Charge / Orifice Size for Various Matched Systems - 1 Phase							
Outdoor Unit	E1RD018S06	E1RD024S06	E1RD030S06	E1RD036S06	E1RD042S06	E1RD048S06	E1RD060S06
Required TXV	1TVM2A1	1TVM2A1	1TVM2A1	1TVM2A1	1TVM2C1	1TVM2C1	1TVM2C1
Factory R-22 Charge, lbs-oz	7 - 1	6 - 9	8 - 9	8 - 7	8 - 7	12 - 8	16 - 7
Indoor Coil^{1,2}	Additional Charge, Oz						
FC/MC/PC/UC18A2A	0	-	-	-	-	-	-
FC/MC/PC/UC18B2A	0	-	-	-	-	-	-
FC/MC/PC/UC24A2A	-	0	-	-	-	-	-
FC/MC/PC/UC24B2A	-	0	-	-	-	-	-
FC/MC/PC/UC30A2A	-	0	-	-	-	-	-
FC/MC/PC/UC30B2A	-	0	-	-	-	-	-
FC/MC/PC35B2A	-	-	0	9	-	-	-
FC/MC/PC35C2C	-	-	0	9	-	-	-
FC/MC/PC/UC42B2C	-	-	0	9	-	-	-
FC/MC/PC/UC42C2C	-	-	0	9	-	-	-
FC/MC/PC/UC48C2C	-	-	-	9	14	-	-
FC/MC/PC/UC48D2C	-	-	-	9	14	-	-
FC/PC/UC60C2C	-	-	-	-	-	7	7
FC/MC/PC/UC60D2C	-	-	-	-	-	7	7
MC61D2C	-	-	-	-	-	7	7
HC18A2A	0	-	-	-	-	-	-
HC30A2A	-	0	-	-	-	-	-
HC36B2A	-	-	0	-	-	-	-
HC42C2C	-	-	-	9	-	-	-
HC60C2C	-	-	-	-	-	7	7
HD24A2A	-	0	-	-	-	-	-
HD36B2A	-	-	0	9	-	-	-
HD48C2C	-	-	-	-	14	-	-
HD60D2C	-	-	-	-	-	7	7
AHP18B2A	0	-	-	-	-	-	-
AHP24B2A	-	0	-	-	-	-	-
AHP30B2A	-	-	0	-	-	-	-
AHP36C2A	-	-	-	9	-	-	-
AHP42C2C	-	-	-	9	-	-	-
AHP/SHP48D2C	-	-	-	-	14	7	-
AHP/SHP60D2C	-	-	-	-	-	7	7
AV24B2A	0	0	-	-	-	-	-
AV36C2A	-	-	0	9	-	-	-
AV/SV48D2C	-	-	-	-	14	7	-
AV/SV60D2C	-	-	-	-	-	-	7
FC/MC/PC/UC18A3X	0	-	-	-	-	-	-
FC/MC/PC/UC18B3X	0	-	-	-	-	-	-
FC/MC/PC/UC24A3X	-	0	-	-	-	-	-
FC/MC/PC/UC24B3X	-	0	-	-	-	-	-
FC/MC/PC/UC30A3X	-	0	-	-	-	-	-
FC/MC/PC/UC30B3X	-	0	-	-	-	-	-
FC/MC/PC35B3X	-	-	0	9	-	-	-
FC/MC/PC35X3X	-	-	0	9	-	-	-
FC/MC/PC/UC42B3X	-	-	0	9	-	-	-
FC/MC/PC/UC42X3X	-	-	0	9	-	-	-
FC/MC/PC/UC48C3X	-	-	-	9	14	-	-
FC/MC/PC/UC48D3X	-	-	-	9	14	-	-
FC/PC/UC60C3X	-	-	-	-	-	7	7
FC/MC/PC/UC60D3X	-	-	-	-	-	7	7
MC61D3X	-	-	-	-	-	7	7
HC18A3X	0	-	-	-	-	-	-
HC30A3X	-	0	-	-	-	-	-
HC36B3X	-	-	0	-	-	-	-
HC42C3X	-	-	-	9	-	-	-
HC60C3X	-	-	-	-	-	7	7

For Notes See Page 4.

Additional R-22 Charge / Orifice Size for Various Matched Systems - 1 Phase (Continued)							
Outdoor Unit	E1RD018S06	E1RD024S06	E1RD030S06	E1RD036S06	E1RD042S06	E1RD048S06	E1RD060S06
Required TXV	1TVM2A1	1TVM2A1	1TVM2A1	1TVM2A1	1TVM2C1	1TVM2C1	1TVM2C1
Factory R-22 Charge, lbs-oz	7 - 1	6 - 9	8 - 9	8 - 7	8 - 7	12 - 8	16 - 7
Indoor Coil^{1,2}	Additional Charge, Oz						
HD24A3X	-	0	-	-	-	-	-
HD36B3X	-	-	0	9	-	-	-
HD48C3X	-	-	-	-	14	-	-
HD60D3X	-	-	-	-	-	7	7
AHP18B3X	0	-	-	-	-	-	-
AHP24B3X	-	0	-	-	-	-	-
AHP30B3X	-	-	0	-	-	-	-
AHP36C3X	-	-	-	9	-	-	-
AHP42C3X	-	-	-	9	-	-	-
AHP/SHP48D3X	-	-	-	-	14	7	-
AHP/SHP60D3X	-	-	-	-	-	7	7
AV24B3X	0	0	-	-	-	-	-
AV36C3X	-	-	0	9	-	-	-
AV/SV48D3X	-	-	-	-	14	7	-
AV/SV60D3X	-	-	-	-	14	7	7
F*FP024H06T2A	0	-	-	-	-	-	-
F*FP030H06T2A	-	0	-	-	-	-	-
F*FP040H06T2A	-	-	0	9	-	-	-
F*FP042H06T2A	-	-	-	9	-	-	-
F*FV060H06T2C	-	-	-	-	-	7	7

FOOTNOTES:

1. Systems matched with furnace or air handlers not equipped with blower-off delays may require blower Time Delay Kit 2FD06700224.
2. PC coils cannot be used in downflow or horizontal applications. FC coils cannot be used in horizontal applications.

* This loose coil match does not achieve 13 SEER.

PROCEDURES:

1. Unit factory charge listed on the unit nameplate includes refrigerant for the condenser, the smallest evaporator and 15 feet of interconnecting line tubing.
2. Verify the orifice size and the additional charge required for the specific evaporator coil in the system using the above table.
3. Additional charge for the amount of interconnecting line tubing greater than 15 feet at the rate specified in the table above.
4. Permanently mark the unit nameplate with the total system charge. Total System Charge = Base charge (as shipped) + adder for evaporator + adder for line set.
5. If the orifice in the evaporator was changed, verify the evaporator nameplate has been marked with the correct orifice/TXV size.

PHYSICAL AND ELECTRICAL DATA - 3 PHASE

MODEL		E1RD 030S25	E1RD 036S25	E1RD 042S25	E1RD 048S25	E1RD 060S25	E1RD 030S46	E1RD 036S46	E1RD 042S46	E1RD 048S46	E1RD 060S46
Unit Supply Voltage		208-230V, 3 ϕ , 60Hz					460V, 3 ϕ , 60Hz				
Normal Voltage Range ¹		187 to 252					432 to 532				
Minimum Circuit Ampacity		12.1	14.3	14.4	20.2	23.1	5.6	6.9	7.2	9.5	11.2
Max. Overcurrent Device Amps ²		20	20	20	35	40	15	15	15	15	15
Min. Overcurrent Device Amps ³		15	15	15	25	25	15	15	15	15	15
Compressor Type		Recip	Recip	Recip	Scroll	Scroll	Recip	Recip	Recip	Scroll	Scroll
Compressor Amps	Rated Load	8.5	10.2	10.4	10.2	16	3.9	4.9	6.1	6.1	8
	Locked Rotor	62	72	71	95	123	30	45	45	45	70
Crankcase Heater		Yes	Yes	Yes	No	No	Yes	Yes	Yes	No	No
Fan Motor Amps	Rated Load	1.5	1.5	1.5	1.5	1.5	0.7	0.7	0.7	0.7	0.7
Fan Diameter Inches		22	22	22	24	24	22	22	22	24	24
Fan Motor	Rated HP	1/4	1/4	1/4	1/4	1/4	1/4	1/4	1/4	1/4	1/4
	Nominal RPM	850	850	850	850	850	850	850	850	850	850
	Nominal CFM	3450	3500	3500	3400	3500	3450	3500	3500	3400	3500
Coil	Face Area Sq. Ft.	20.96	23.58	23.58	24.00	27.00	20.96	23.58	23.58	24.00	27.00
	Rows Deep	1	1	1	2	2	1	1	1	2	2
	Fin / Inches	22	22	22	18	18	22	22	22	18	18
Liquid Line Set OD (Field Installed)		3/8	3/8	3/8	3/8	3/8	3/8	3/8	3/8	3/8	3/8
Vapor Line Set OD (Field Installed)		7/8	7/8	7/8	7/8	1-1/8	7/8	7/8	7/8	7/8	1-1/8
Unit Charge (Lbs. - Oz.) ⁴		8 - 7	8 - 7	8 - 7	12 - 8	16 - 7	8 - 7	8 - 7	8 - 7	12 - 8	16 - 7
Charge Per Foot, Oz.		0.70	0.70	0.70	0.70	0.76	0.70	0.70	0.70	0.70	0.78
Operating Weight Lbs.		196	208	208	250	294	196	208	208	250	294

1. Rated in accordance with ARI Standard 110, utilization range "A".
2. Dual element fuses or HACR circuit breaker. Maximum allowable overcurrent protection.
3. Dual element fuses or HACR circuit breaker. Minimum recommended overcurrent protection.
4. The Unit Charge is correct for the outdoor unit, matched indoor coil and 15 feet of refrigerant tubing. For tubing lengths other than 15 feet, add or subtract the amount of refrigerant, using the difference in length multiplied by the per foot value. If line exceeds 25 feet, you may refer to publications software 036-68001-001 for proper line sizing.

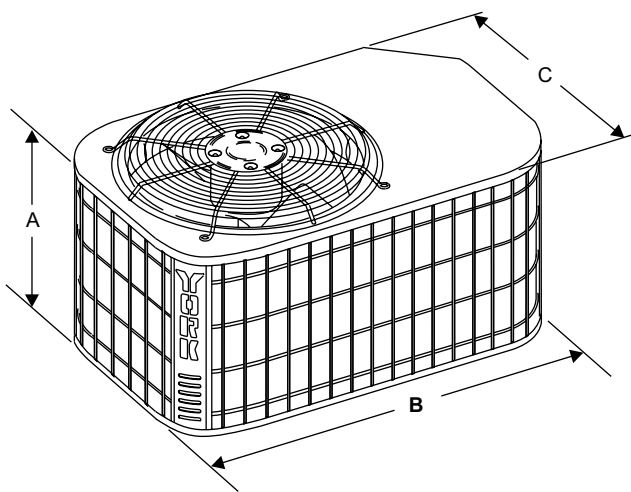

All dimensions are in inches. They are subject to change without notice. Certified dimensions will be provided upon request.

DIMENSIONS

Unit Model	Dimensions (Inches)			Refrigerant Connection Service Valve Size	
	A ¹	B	C	Liquid	Vapor
030	35	37	27	3/8"	7/8"
036	39	37	27		
042	39	37	27		
048	34	43	32		
060	38	43	32		7/8**

1. Including Fan Guard.

* Adapter fitting required for 1-1/8" line set.

Additional R-22 Charge / Orifice Size for Various Matched Systems - 3 Phase					
Outdoor Unit	E1RD030S(25,46)	E1RD036S(25,46)	E1RD042S(25,46)	E1RD048S(25,46)	E1RD060S(25,46)
Required TXV	1TVM2A1	1TVM2A1	1TVM2C1	1TVM2C1	1TVM2C1
Factory R-22 Charge, lbs-oz	8 - 9	8 - 7	8 - 7	12 - 8	16 - 9
Indoor Coil¹	Additional Charge, Oz				
FC/MC/PC/UC35B2C	0	9	–	–	–
FC/MC/PC/UC35C2C	0	9	–	–	–
FC/MC/PC/UC42B2C	0	9	–	–	–
FC/MC/PC/UC42C2C	0	9	–	–	–
FC/MC/PC/UC48C2C	–	9	14	–	–
FC/MC/PC/UC48D2C	–	9	14	–	–
FC/PC/UC60C2C	–	–	–	7	5
FC/MC/PC/UC60D2C	–	–	–	7	5
MC61D2C	–	–	–	7	5
HC36B2A	0	–	–	–	–
HC42C2C	–	9	–	–	–
HC60C2C	–	–	–	7	5
HD36B2A	0	9	–	–	–
HD48C2C	–	–	14	–	–
HD60D2C	–	–	–	7	5
AHP30B2A	0	–	–	–	–
AHP36C2A	–	9	–	–	–
AHP42C2C	–	9	–	–	–
AHP/SHP48D2C	–	–	14	7	–
AHP/SHP60D2C	–	–	–	7	5
FC/MC/PC/UC42B3X	0	9	–	–	–
FC/MC/PC/UC42X3X	0	9	–	–	–
FC/MC/PC/UC48C3X	–	9	14	–	–
FC/MC/PC/UC48D3X	–	9	14	–	–
FC/PC/UC60C3X	–	–	–	7	5
FC/MC/PC/UC60D3X	–	–	–	7	5
MC61D3X	–	–	–	7	5
HC36B3X	0	–	–	–	–
HC42C3X	–	9	–	–	–
HC60C3X	–	–	–	7	5
HD36B3X	0	9	–	–	–
HD48C3X	–	–	14	–	–
HD60D3X	–	–	–	7	5
AHP30B3X	0	–	–	–	–
AHP36C3X	–	9	–	–	–
AHP42C3X	–	9	–	–	–
AHP/SHP48D3X	–	–	14	7	–
AHP/SHP60D3X	–	–	–	7	5
F*FP040H06T2A	0	9	–	–	–
F*FP042H06T2A	–	9	–	–	–

FOOTNOTES:

1. Systems matched with furnace or air handlers not equipped with blower-off delays may require blower Time Delay Kit 2FD06700224.

PROCEDURES:

1. Unit factory charge listed on the unit nameplate includes refrigerant for the condenser, the smallest evaporator and 15 feet of inter-connecting line tubing.
2. Verify the TXV and additional charge required for specific evaporator coil in the system using the above table.
3. Additional charge for the amount of interconnecting line tubing greater than 15 feet at the rate specified in the table above.
4. Permanently mark the unit nameplate with the total system charge. Total System Charge = Base Charge (as shipped) + adder for evaporator + adder for line set.

COOLING CAPACITY - With Air Handler Coils

UNIT MODEL	AIR HANDLER		COIL MODEL ¹	COOLING				
	MODEL	W		RATED CFM	NET MBH		SEER	EER
					TOTAL	SENS.		
1 & 3 PH 13 SEER HP WITH MA								
E1RD018S06	MA08B	17	FC/MC18B	600	18.0	12.4	13.00	11.00
E1RD024S06	MA08B	17	FC/MC24B	800	23.2	16.8	13.00	11.00
	MA08B	17	FC/MC30B	800	23.2	16.8	13.00	11.00
E1RD030S06	MA12B	17	FC/MC35B	1000	28.4	20.3	13.00	11.00
	MA12B	17	FC/MC42B	1000	28.4	20.3	13.00	11.00
E1RD030S(25,46)	MA12B	17	FC/MC35B	1000	28.0	20.0	13.00	11.00
	MA12B	17	FC/MC42B	1000	28.0	20.0	13.00	11.00
E1RD036S06	MA12B	17	FC/MC35B	1200	34.6	25.3	13.00	11.00
	MA12B	17	FC/MC42B	1200	34.6	25.3	13.00	11.00
	MA14D	24	FC/MC48D	1200	35.0	25.6	13.00	11.00
E1RD036S(25,46)	MA12B	17	FC/MC35B	1200	34.0	24.8	13.00	11.00
	MA12B	17	FC/MC42B	1200	34.0	24.8	13.00	11.00
E1RD042S06	MA14D	24	FC/MC48D	1200	34.4	25.1	13.00	11.00
	MA16C	21	FC/MC48C	1400	41.0	30.8	13.00	11.00
E1RD042S(25,46)	MA14D	24	FC/MC48D	1400	41.0	30.8	13.00	11.00
	MA16C	21	FC/MC48C	1400	40.0	30.0	13.00	11.00
E1RD048S06	MA14D	24	FC/MC48D	1400	40.0	30.0	13.00	11.00
	MA16C	21	FC60C	1600	46.0	35.4	13.00	11.00
	MA20D	21	FC/MC60D	1600	46.0	35.4	13.00	11.00
E1RD048S(25,46)	MA20D	24	MC61D	1600	46.0	35.5	13.00	11.00
	MA16C	21	FC60C	1600	45.0	34.6	13.00	11.00
	MA20D	21	FC/MC60D	1600	45.0	34.6	13.00	11.00
E1RD060S06	MA20D	24	MC61D	1600	45.0	34.7	13.00	11.00
	MA20D	24	FC/MC60D	1800	55.0	40.7	13.00	11.00
E1RD060S(25,46)	MA20D	24	MC61D	1800	55.5	41.0	13.00	11.00
	MA20D	24	FC/MC60D	1800	54.5	40.3	13.00	11.00
MA20D	24	MC61D	1800	55.0	40.6	13.00	11.00	
1 PH 13 SEER HP WITH MV - VARIABLE SPEED								
E1RD018S06	MV12B	17	FC/MC18B	600	18.0	12.6	14.00	12.00
E1RD024S06	MV12B	17	FC/MC24B	800	23.6	16.7	14.00	12.00
	MV12B	17	FC/MC30B	800	23.6	16.7	14.00	12.00
E1RD030S06	MV12B	17	FC/MC35B	1000	29.0	20.1	14.00	12.00
	MV16C	21	FC/MC35C	1000	29.0	20.1	14.00	12.00
	MV12B	17	FC/MC42B	1000	29.0	20.1	14.00	12.00
E1RD036S06	MV16C	21	FC/MC42C	1000	29.0	20.1	14.00	12.00
	MV12B	21	FC/MC35C	1200	35.2	25.0	13.50	11.00
	MV16C	21	FC/MC35C	1200	35.2	25.0	14.00	12.00
	MV16C	21	FC/MC42C	1200	35.4	25.2	14.00	12.00
	MV16C	21	FC/MC48C	1200	35.4	25.2	14.00	12.00
E1RD042S06	MV20D	24	FC/MC48D	1200	35.4	25.2	14.00	12.00
E1RD048S06	MV16C	21	FC/MC48C	1400	41.0	30.3	13.75	11.00
E1RD048S06	MV20D	24	FC/MC60D	1600	46.0	34.6	13.50	11.00
	MV20D	24	MC61D	1600	46.5	34.8	13.75	11.00
E1RD060S06	MV20D	24	FC/MC60D	1800	54.0	39.7	13.25	11.00
	MV20D	24	MC61D	1800	55.0	39.9	13.25	11.00

For Notes See Page 8

COOLING CAPACITY - With Air Handler Coils (Continued)

UNIT MODEL	AIR HANDLER		COIL MODEL ¹	COOLING				
	MODEL	W		RATED CFM	NET MBH		SEER	EER
					TOTAL	SENS.		
1 PH 13 SEER AC WITH AV / SV - VARIABLE SPEED								
E1RD018S06	AV24	17	—	600	18.0	12.6	14.00	12.00
E1RD024S06	AV24	17	—	800	23.8	16.7	14.00	12.00
E1RD030S06	AV36	17	—	1000	29.2	20.1	14.00	12.00
E1RD036S06	AV36	21	—	1200	35.0	25.2	14.00	12.00
E1RD042S06	AV/SV48	21	—	1400	41.5	30.3	14.00	12.00
E1RD048S06	AV/SV48	24	—	1600	46.5	34.8	13.75	11.00
E1RD060S06	AV/SV60	24	—	1800	55.0	39.9	13.25	11.00
1 & 3 PH 13 SEER HP WITH AHP / F*FP / F*FV								
E1RD018S06	F*FP024	17	—	600	18.0	11.4	13.00	11.00
	AHP18	17	—	600	18.0	11.4	13.00	11.00
E1RD024S06	F*FP030	17	—	800	23.2	16.4	13.00	11.00
	AHP24	17	—	800	23.0	16.4	13.00	11.00
E1RD030S06	F*FP040	21	—	1000	28.0	19.5	13.00	11.00
	AHP30	17	—	1000	28.4	19.5	13.00	11.00
E1RD030S(25,46)	F*FP040	21	—	1000	27.6	19.2	13.00	11.00
	AHP30	17	—	1000	28.0	19.2	13.00	11.00
	AHP30	17	—	1000	28.0	19.2	13.00	11.00
E1RD036S06	F*FP040	21	—	1200	34.6	25.4	13.00	11.00
	F*FP042	21	—	1200	34.6	25.4	13.00	11.00
	AHP36	21	—	1200	34.4	25.4	13.00	11.00
	AHP42	21	—	1200	34.6	25.3	13.00	11.00
E1RD036S(25,46)	F*FP040	21	—	1200	34.0	24.9	13.00	11.00
	F*FP042	21	—	1200	34.0	24.9	13.00	11.00
	AHP36	21	—	1200	33.8	24.9	13.00	11.00
	AHP42	21	—	1200	34.0	24.8	13.00	11.00
E1RD042S06	AHP/SHP48	24	—	1400	41.0	30.7	13.00	11.00
E1RD042S(25,46)	AHP/SHP48	24	—	1400	40.0	29.9	13.00	11.00
E1RD048S06	F*FV060	24	—	1600	46.0	34.6	13.50	11.00
	AHP/SHP48	24	—	1600	46.0	35.3	13.00	11.00
	AHP/SHP60	24	—	1600	46.0	34.6	13.25	11.00
E1RD048S(25,46)	F*FV060	24	—	1600	45.0	33.8	13.50	11.00
	AHP/SHP48	24	—	1600	45.0	34.5	13.00	11.00
	AHP/SHP60	24	—	1600	45.0	33.8	13.25	11.00
E1RD060S06	F*FV060	24	—	1800	54.0	39.7	13.25	11.00
	AHP/SHP60	24	—	1800	55.0	39.7	13.00	11.00
E1RD060S(25,46)	F*FV060	24	—	1800	53.5	39.3	13.25	11.00
	AHP/SHP60	24	—	1800	54.5	39.3	13.00	11.00

Rated in accordance with DOE test procedures (Federal Register 12-27-79 and 3-18-88) and ARI Standards 210/240.

Cooling MBH based on 80°F entering air temperature, 50% RH, and rated air flow.

EER (Energy Efficiency Ratio) is the total cooling output in BTU's at a 95°F outdoor ambient divided by the total electric power in watt-hours at those conditions.

SEER (Seasonal Energy Efficiency Ratio) is the total cooling output in BTU's during a normal annual usage period for cooling divided by the total electric power input in watt-hours during the same period.

1. MC coils available with a factory installed horizontal drain pan. See price pages for specific model number.

— = Not Applicable.

Go to www.ari.org/aridirectory for the latest additional matches.

COOLING CAPACITY - Upflow, Downflow, and Horizontal Furnaces and Coils

UNIT MODEL	FURNACE**		COIL MODEL	COOLING				
	CFM RANGE (MIN.-MAX.)	W		RATED CFM	NET MBH		SEER ¹	EER
					TOTAL	SENS.		
E1RD018S06	450 750	14,17	FC/MC/PC/UC18	600	18.0	12.4	13.00	11.00
		14	HC18	600	17.8	12.1	13.00	11.00
E1RD024S06	600 1000	14,17	FC/MC/PC/UC24	800	23.2	16.7	13.00	11.00
		14,17	FC/MC/PC/UC30	800	23.2	16.7	13.00	11.00
		14	HC30	760	23.4	16.6	13.00	11.00
		–	HD24	800	23.2	16.7	13.00	11.00
E1RD030S06	800 1200	17,21	FC/MC/PC35	1000	28.4	20.3	13.00	11.00
		17,21	FC/MC/PC/UC42	1000	28.4	20.3	13.00	11.00
		17	HC36	950	28.0	19.6	13.00	11.00
		–	HD36	1000	28.6	20.3	13.00	11.00
E1RD030S(25,46)	800 1200	17,21	FC/MC/PC35	1000	28.0	20.0	13.00	11.00
		17,21	FC/MC/PC/UC42	1000	28.0	20.0	13.00	11.00
		17	HC36	950	27.6	19.3	13.00	11.00
		–	HD36	1000	28.2	20.0	13.00	11.00
E1RD036S06	1000 1400	17,21	FC/MC/PC35	1200	34.6	25.3	13.00	11.00
		17,21	FC/MC/PC/UC42	1200	34.6	25.3	13.00	11.00
		21,24	FC/MC/PC/UC48	1200	35.0	25.6	13.00	11.00
		21	HC42	1140	34.4	24.5	13.00	11.00
		–	HD36	1200	34.4	25.2	13.00	11.00
E1RD036S(25,46)	1000 1400	17,21	FC/MC/PC35	1200	34.0	24.8	13.00	11.00
		17,21	FC/MC/PC/UC42	1200	34.0	24.8	13.00	11.00
		21,24	FC/MC/PC/UC48	1200	34.4	25.1	13.00	11.00
		21	HC42	1140	33.8	24.0	13.00	11.00
		–	HD36	1200	33.8	24.7	13.00	11.00
E1RD042S06	1200 1000	21,24	FC/MC/PC/UC48	1400	41.0	30.8	13.00	11.00
		–	HD48	1400	40.5	30.3	13.00	11.00
E1RD042S(25,46)	1200 1600	21,24	FC/MC/PC/UC48	1400	40.0	30.0	13.00	11.00
		–	HD48	1400	39.5	29.5	13.00	11.00
E1RD048S06	1400 1800	21,24	FC/MC/PC/UC60	1600	45.0	35.4	13.00	11.00
		24	MC61	1600	46.0	35.5	13.00	11.00
		24	HC60	1520	45.5	34.3	13.00	11.00
		–	HD60	1600	45.0	34.7	13.00	11.00
E1RD048S(25,46)	1400 1800	21,24	FC/MC/PC/UC60	1600	44.0	34.6	13.00	11.00
		24	MC61	1600	45.0	34.7	13.00	11.00
		24	HC60	1520	44.5	33.5	13.00	11.00
		–	HD60	1600	44.0	33.9	13.00	11.00
E1RD060S06	1600 2000	21,24	FC/MC/PC/UC60	1800	55.0	40.7	13.00	11.00
		24	MC61	1800	55.5	41.0	13.00	11.00
		24	HC60	1710	54.5	39.7	13.00	11.00
		–	HD60	1800	54.0	39.9	13.00	11.00
E1RD060S(25,46)	1600 2000	21,24	FC/MC/PC/UC60	1800	54.5	40.3	13.00	11.00
		24	MC61	1800	55.0	40.6	13.00	11.00
		24	HC60	1710	54.0	39.3	13.00	11.00
		–	HD60	1800	53.5	39.5	13.00	11.00

1. Requires a 2FD06700224 Blower Time Delay unless a standard furnace is equipped with one.

** Refer to Quick Selection Chart for specific furnace match-up.

COOLING CAPACITY - With Variable Speed Furnaces

UNIT MODEL	VARIABLE SPEED FURNACE MODEL	COIL MODEL ¹	W	COOLING				
				RATED CFM	NET MBH		SEER	EER
					TOTAL	SENS.		
1 PH 13 SEER HP WITH VARIABLE SPEED FURNACES²								
E1RD018S06	PV8*A12	FC/MC/PC18A	14	600	18.0	12.5	14.00	12.00
	PV9*A12	FC/MC/PC18A	14	600	18.0	12.5	14.00	12.00
	P(C,V)9*B12	FC/MC/PC18B	17	600	18.0	12.6	14.00	12.00
	PV8*A12	HC18	14	600	18.0	12.5	14.00	12.00
	PV9*A12	HC18	14	600	18.0	12.5	14.00	12.00
E1RD024S06	PV8*A12	FC/MC/PC24A	14	800	23.2	16.7	14.00	12.00
	PV9*A12	FC/MC/PC24A	14	800	23.2	16.7	14.00	12.00
	P(C,V)9*B12	FC/MC/PC24B	17	800	23.2	16.6	14.00	12.00
	PV8*A12	FC/MC/PC30A	14	800	23.2	16.7	14.00	12.00
	PV9*A12	FC/MC/PC30A	14	800	23.2	16.7	14.00	12.00
	P(C,V)9*B12	FC/MC/PC30B	17	800	23.2	17.2	14.00	12.00
	PV8*A12	HC30	14	800	23.2	17.2	14.00	12.00
	PV9*A12	HC30	14	800	23.2	16.9	14.00	12.00
	PV8*A12	HD30	–	800	23.2	16.9	14.00	12.00
PV9*A12	HD30	–	800	23.2	16.9	14.00	12.00	
E1RD030S06	PV8*B16	FC/MC/PC35B	17	1000	29.0	20.4	14.00	12.00
	P(C,V)9*B12	FC/MC/PC35B	17	1000	29.0	20.4	14.00	12.00
	PV8*C16	FC/MC/PC35C	21	1000	29.0	20.3	14.00	12.00
	P(C,V)9*C16	FC/MC/PC35C	21	1000	29.0	20.4	14.00	12.00
	PV8*B16	FC/MC/PC42B	17	1000	29.0	20.4	14.00	12.00
	P(C,V)9*B12	FC/MC/PC42B	17	1000	29.0	20.4	14.00	12.00
	PV8*C16	FC/MC/PC42C	21	1000	29.0	20.3	14.00	12.00
	P(C,V)9*C16	FC/MC/PC42C	21	1000	29.0	20.4	14.00	12.00
	PV8*B16	HC36	17	1000	29.0	20.4	14.00	12.00
	P(C,V)9*B12	HC36	17	1000	29.0	20.4	14.00	12.00
	PV8*B16	HD36	–	1000	29.0	20.4	14.00	12.00
P(C,V)9*B12	HD36	–	1000	29.0	20.4	14.00	12.00	
E1RD036S06	PV8*B16	FC/MC/PC42B	17	1200	35.2	25.7	13.50	11.00
	P(C,V)9*B12	FC/MC/PC42B	17	1200	35.2	25.7	13.25	11.00
	PV8*C16	FC/MC/PC42C	21	1200	35.2	25.6	13.75	11.00
	PV8*C20	FC/MC/PC42C	21	1200	35.2	25.6	14.00	12.00
	P(C,V)9*C16	FC/MC/PC42C	21	1200	35.0	25.5	13.25	11.00
	P(C,V)9*C20	FC/MC/PC42C	21	1200	35.0	25.4	13.50	11.00
	PV8*C20	FC/MC/PC48C	21	1200	35.4	25.7	14.00	12.00
	P(C,V)9*C16	FC/MC/PC48C	21	1200	35.4	25.7	14.00	12.00
	P(C,V)9*C20	FC/MC/PC48C	21	1200	35.4	25.4	14.00	12.00
	P(C,V)9*D20	FC/MC/PC48D	24	1200	35.4	25.6	14.00	12.00
	PV8*C20	HC42	21	1200	35.2	25.4	14.00	12.00
	P(C,V)9*C16	HC42	21	1200	35.0	25.6	13.25	11.00
	P(C,V)9*C20	HC42	21	1200	35.0	25.6	13.50	11.00
	PV8*C20	HD36	–	1200	35.2	25.8	14.00	12.00
	P(C,V)9*C16	HD36	–	1200	35.0	25.5	13.25	11.00
P(C,V)9*C20	HD36	–	1200	35.0	25.6	13.50	11.00	
E1RD042S06	PV8*C20	FC/MC/PC48C	21	1400	41.0	30.9	13.50	11.00
	P(C,V)9*C16	FC/MC/PC48C	21	1400	41.0	30.9	13.50	11.00
	P(C,V)9*C20	FC/MC/PC48C	21	1400	41.0	30.9	13.50	11.00
	P(C,V)9*D20	FC/MC/PC48D	24	1400	41.0	30.9	13.50	11.00
	PV8*C20	HD48	–	1400	40.0	30.2	13.50	11.00
	P(C,V)9*C16	HD48	–	1400	40.5	30.6	13.25	11.00
	P(C,V)9*C20	HD48	–	1400	40.0	30.1	13.25	11.00

For Notes See Page 11

COOLING CAPACITY - With Variable Speed Furnaces (Continued)

UNIT MODEL	VARIABLE SPEED FURNACE MODEL	COIL MODEL ¹	W	COOLING				
				RATED CFM	NET MBH		SEER	EER
					TOTAL	SENS.		
1 PH 13 SEER HP WITH VARIABLE SPEED FURNACES²								
E1RD048S06	P(C,V)9"D20	FC/MC/PC60D	24	1600	46.0	35.5	13.25	11.00
	PV8"C16	FC/PC60C	21	1500	45.5	35.1	13.25	11.00
	PV8"C20	FC/PC60C	21	1600	46.0	35.4	13.25	11.00
	P(C,V)9"C16	FC/PC60C	21	1600	46.0	35.5	13.25	11.00
	P(C,V)9"C20	FC/PC60C	21	1600	46.0	34.5	13.25	11.00
	P(C,V)9"D20	HC60	24	1600	46.0	35.5	13.25	11.00
	PV8"C20	HD60	–	1600	46.0	35.5	13.25	11.00
	P(C,V)9"C20	HD60	–	1600	46.0	34.8	13.25	11.00
P(C,V)9"D20	MC61D	24	1600	46.5	35.1	13.25	11.00	
E1RD060S06	P(C,V)9"D20	FC/MC/PC60D	24	1620	54.5	38.6	13.25	11.00
	PV8"C20	FC/PC60C	21	1730	54.5	38.6	13.25	11.00
	P(C,V)9"C20	FC/PC60C	21	1620	54.0	39.6	13.10	11.00
	P(C,V)9"D20	HC60	24	1620	54.5	38.9	13.25	11.00
	PV8"C20	HD60	–	1620	54.5	38.5	13.25	11.00
	P(C,V)9"D20	HD60	–	1620	54.5	38.3	13.25	11.00
	P(C,V)9"D20	MC61D	24	1620	54.0	38.9	13.25	11.00

1. MC coils available with a factory installed horizontal drain pan. See price pages for specific model number.
2. Variable speed furnaces have B.O.D (Blower on Delay) standard.

HEATING PERFORMANCE - With Air Handler

UNIT MODEL*	AIR HANDLER	COIL ¹ MODEL	ARI HEATING ²						
			47°F			17°F			HSPF
			MBH	COP	KW	MBH	COP	KW	STD
1 & 3 PH 13 SEER HP WITH MA									
E1RD018S06	MA08B	FC/MC18B	18.0	3.62	1.46	10.5	2.28	1.35	8.00
E1RD024S06	MA08B	FC/MC24B	23.0	3.44	1.96	13.1	2.30	1.67	8.00
	MA08B	FC/MC30B	23.0	3.44	1.96	13.1	2.30	1.67	8.00
E1RD030S06	MA12B	FC/MC35B	30.0	3.66	2.48	16.2	2.22	2.14	8.00
	MA12B	FC/MC42B	30.0	3.66	2.48	16.2	2.22	2.14	8.00
E1RD030S(25,46)	MA12B	FC/MC35B	29.0	3.66	2.32	15.7	3.66	1.25	8.00
	MA12B	FC/MC42B	29.0	3.66	2.32	15.7	3.66	1.25	8.00
E1RD036S06	MA12B	FC/MC35B	34.4	3.44	2.93	20.4	2.50	2.39	8.40
	MA12B	FC/MC42B	34.4	3.44	2.93	20.4	2.50	2.39	8.40
	MA14D	FC/MC48D	36.0	3.86	2.73	22.4	2.78	2.36	9.00
E1RD036S(25,46)	MA12B	FC/MC35B	34.0	3.66	2.72	20.2	3.66	1.61	8.00
	MA12B	FC/MC42B	34.0	3.66	2.72	20.2	3.66	1.61	8.00
	MA14D	FC/MC48D	35.0	3.66	2.80	21.8	3.66	1.74	8.00
E1RD042S06	MA14D	FC/MC48D	42.0	3.62	3.40	25.0	2.56	2.86	8.50
	MA16C	FC/MC48C	42.0	3.62	3.40	25.0	2.56	2.86	8.50
E1RD042S(25,46)	MA14D	FC/MC48D	41.0	3.66	3.28	24.4	3.66	1.95	8.00
	MA16C	FC/MC48C	41.0	3.66	3.28	24.4	3.66	1.95	8.00
E1RD048S06	MA16C	FC60C	48.0	3.50	4.02	29.6	2.34	3.71	8.00
	MA20D	FC/MC60D	48.0	3.50	4.02	29.6	2.34	3.71	8.00
	MA20D	MC61D	48.0	3.50	4.02	29.6	2.34	3.71	8.00
E1RD048S(25,46)	MA16C	FC60C	47.0	3.66	3.76	29.0	3.66	2.32	8.00
	MA20D	FC/MC60D	47.0	3.66	3.76	29.0	3.66	2.32	8.00
	MA20D	MC61D	47.0	3.66	3.76	29.0	3.66	2.32	8.00
E1RD060S06	MA20D	FC/MC60D	58.0	3.52	4.83	35.0	2.32	4.42	8.00
	MA20D	MC61D	58.0	3.52	4.83	35.0	2.32	4.42	8.00
E1RD060S(25,46)	MA20D	FC/MC60D	57.0	3.66	4.56	34.4	3.66	2.75	8.00
	MA20D	MC61D	57.0	3.66	4.56	34.4	3.66	2.75	8.00
1 PH 13 SEER HP WITH MV - VARIABLE SPEED									
E1RD018S06	MV12B	FC/MC18B	17.5	3.86	1.33	10.0	2.42	1.21	8.40
E1RD024S06	MV12B	FC/MC24B	22.2	3.68	1.77	12.5	2.46	1.49	8.30
	MV12B	FC/MC30B	22.2	3.68	1.77	12.5	2.46	1.49	8.30
E1RD030S06	MV12B	FC/MC35B	30.4	3.84	2.32	15.6	2.30	1.99	8.10
	MV16C	FC/MC35C	30.2	3.90	2.27	15.5	2.34	1.94	8.20
	MV12B	FC/MC42B	30.4	3.84	2.32	15.6	2.30	1.99	8.10
	MV16C	FC/MC42C	30.2	3.90	2.27	15.5	2.34	1.94	8.20
E1RD036S06	MV16C	FC/MC35C	32.0	3.54	2.65	18.5	2.58	2.10	8.50
	MV16C	FC/MC42C	32.0	3.54	2.65	18.5	2.58	2.10	8.50
	MV16C	FC/MC48C	35.2	4.10	2.52	21.6	2.96	2.14	9.00
	MV20D	FC/MC48D	35.2	4.10	2.52	21.6	2.96	2.14	9.00
E1RD042S06	MV16C	FC/MC48C	41.5	3.72	3.27	24.4	2.64	2.71	8.75
	MV20D	FC/MC48D	41.5	3.72	3.27	24.4	2.64	2.71	8.75
E1RD048S06	MV20D	FC/MC60D	47.5	3.58	3.89	29.2	2.40	3.56	8.25
	MV20D	MC61D	47.5	3.60	3.87	29.2	2.40	3.56	8.30
E1RD060S06	MV20D	FC/MC60D	57.5	3.56	4.73	34.6	2.34	4.33	8.15
	MV20D	MC61D	57.5	3.58	4.71	34.6	2.36	4.30	8.20

For Notes See Page 13

HEATING PERFORMANCE - With Air Handler (Continued)

UNIT MODEL*	AIR HANDLER	COIL ¹ MODEL	ARI HEATING ²						
			47°F			17°F			HSPF
			MBH	COP	KW	MBH	COP	KW	STD
1 PH 13 SEER HP WITH AV - VARIABLE SPEED									
E1RD018S06	AV24	—	17.6	3.86	1.33	10.1	2.42	1.21	8.40
E1RD024S06	AV24	—	22.2	3.68	1.77	12.4	2.46	1.49	8.40
E1RD030S06	AV36	—	30.0	3.90	2.27	15.5	2.34	1.94	8.25
E1RD036S06	AV36	—	35.4	4.10	2.52	21.8	2.96	2.14	9.30
E1RD042S06	AV/SV48	—	41.0	3.72	3.27	24.2	2.64	2.71	8.75
E1RD048S06	AV/SV48	—	47.0	3.60	3.87	29.0	2.40	3.56	8.20
E1RD060S06	AV/SV60	—	57.0	3.58	4.71	34.8	2.36	4.30	8.15
1 & 3 PH HP SEER AC WITH AHP / F*FP / F*FV									
E1RD018S06	AHP18	—	18.0	3.66	1.43	10.5	2.30	1.32	8.00
	F*FP024	—	17.9	3.66	1.43	10.4	2.30	1.32	8.00
E1RD024S06	AHP24	—	23.0	3.44	1.96	13.1	2.30	1.67	8.00
	F*FP030	—	23.0	3.44	1.96	13.1	2.30	1.67	8.00
E1RD030S06	AHP30	—	29.6	3.66	2.48	16.1	2.22	2.14	8.00
	F*FP040	—	30.0	3.66	2.48	16.2	2.22	2.14	8.00
E1RD030S(25,46)	AHP30	—	28.6	3.66	2.28	15.6	3.66	1.24	8.00
	F*FP040	—	29.0	3.66	2.32	15.7	3.66	1.25	8.00
E1RD036S06	AHP36	—	33.6	3.44	2.91	22.4	2.50	2.37	8.50
	AHP42	—	34.4	3.44	2.93	20.4	2.50	2.39	8.40
	F*FP040	—	34.2	3.44	2.91	20.2	2.50	2.37	8.00
	F*FP042	—	34.2	3.44	2.91	20.2	2.50	2.37	8.00
E1RD036S(25,46)	AHP36	—	33.0	3.66	2.64	22.0	3.66	1.76	8.00
	AHP42	—	34.0	3.66	2.72	20.2	3.66	1.61	8.00
	F*FP040	—	34.0	3.66	2.72	20.1	3.66	1.60	8.00
	F*FP042	—	34.0	3.66	2.72	20.1	3.66	1.60	8.00
E1RD042S06	AHP48	—	42.0	3.56	3.46	25.0	2.52	2.93	8.40
E1RD042S(25,46)	AHP48	—	41.0	3.66	3.28	24.4	3.66	1.95	8.00
E1RD048S06	F*FV060	—	47.5	3.60	3.87	29.2	2.40	3.56	8.30
	AHP48	—	48.0	3.44	4.09	29.6	2.30	3.82	8.00
	AHP60	—	48.0	3.44	4.09	29.6	2.30	3.82	8.10
E1RD048S(25,46)	F*FV060	—	46.5	3.66	3.72	28.6	3.66	2.28	8.00
	AHP48	—	47.0	3.66	3.76	29.0	3.66	2.32	8.00
	AHP60	—	47.0	3.66	3.76	29.0	3.66	2.32	8.00
E1RD060S06	F*FV060	—	57.5	3.56	4.73	34.6	2.34	4.33	8.15
	AHP60	—	58.0	3.46	4.91	35.0	2.28	4.52	8.00
E1RD060S(25,46)	F*FV060	—	56.5	3.66	4.52	34.0	3.66	2.72	8.00
	AHP60	—	57.0	3.66	4.56	34.4	3.66	2.75	8.00

1. Rated CFM same as for cooling.

2. Heating MBH based on ARI standards of 70° DB entering indoor air, 72% RH outdoor air with 25 feet of interconnecting piping and no supplemental electric heat operation.

CP equals MBH output divided by (total KW input x 3.412).

HSPF (Heating Seasonal Performance Factor) is the total heating output during a normal annual usage period for heating divided by the total electric power input during the same period.

— = Not Applicable.

HEATING PERFORMANCE - Upflow Furnace Coils

UNIT MODEL*	COIL ¹ MODEL	ARI HEATING ²						
		47°F			17°F			HSPF STD
		MBH	COP	KW	MBH	COP	KW	
E1RD018S06	FC/MC/PC/UC18	18.0	3.62	1.46	10.5	2.28	1.35	8.00
	HC18	17.9	3.60	1.46	10.4	2.28	1.34	8.00
E1RD024S06	FC/MC/PC/UC24	23.0	3.44	1.96	13.1	2.30	1.67	8.00
	FC/MC/PC/UC30	23.0	3.44	1.96	13.1	2.30	1.67	8.00
	HC30	23.0	3.42	1.97	13.0	2.28	1.67	8.00
	HD24	23.0	3.44	1.96	13.1	2.30	1.67	8.00
E1RD030S06	FC/MC/PC35	30.0	3.66	2.48	16.2	2.22	2.14	8.00
	FC/MC/PC/UC42	30.0	3.66	2.48	16.2	2.22	2.14	8.00
	HC36	30.0	3.66	2.48	16.1	2.22	2.12	8.00
	HD36	30.0	3.66	2.48	16.2	2.22	2.14	8.00
E1RD030S(25,46)	FC/MC/PC35	29.0	3.66	2.32	15.7	3.66	1.25	8.00
	FC/MC/PC/UC42	29.0	3.66	2.32	15.7	3.66	1.25	8.00
	HC36	29.0	3.66	2.32	15.6	3.66	1.24	8.00
	HD36	29.0	3.66	2.32	15.7	3.66	1.25	8.00
E1RD036S06	FC/MC/PC35	34.4	3.44	2.93	20.4	2.50	2.39	8.40
	FC/MC/PC/UC42	34.4	3.44	2.93	20.4	2.50	2.39	8.40
	FC/MC/PC/UC48	36.0	3.86	2.73	22.4	2.78	2.36	9.00
	HC42	35.8	3.86	2.72	22.4	2.78	2.36	9.00
	HD36	36.0	3.86	2.73	22.4	2.78	2.36	9.00
E1RD036S(25,46)	FC/MC/PC35	34.0	3.66	2.72	20.2	3.66	1.61	8.00
	FC/MC/PC/UC42	34.0	3.66	2.72	20.2	3.66	1.61	8.00
	FC/MC/PC/UC48	35.0	3.66	2.80	21.8	3.66	1.74	8.00
	HC42	35.0	3.66	2.80	21.9	3.66	1.75	8.00
	HD36	36.0	3.66	2.88	22.4	3.66	1.79	8.00
E1RD042S06	FC/MC/PC/UC48	42.0	3.62	3.40	25.0	2.56	2.86	8.50
	HD48	41.5	3.62	3.36	25.0	2.56	2.86	8.50
E1RD042S(25,46)	FC/MC/PC/UC48	41.0	3.66	3.28	24.4	3.66	1.95	8.00
	HD48	40.5	3.66	3.24	24.4	3.66	1.95	8.00
E1RD048S06	FC/MC/PC/UC60	48.0	3.50	4.02	29.6	2.34	3.71	8.00
	HC60	48.0	3.50	4.02	29.6	2.34	3.71	8.00
	HD60	48.0	3.50	4.02	29.6	2.34	3.71	8.00
	MC61	48.0	3.50	4.02	29.6	2.34	3.71	8.00
E1RD048S(25,46)	FC/MC/PC/UC60	47.0	3.66	3.76	29.0	3.66	2.32	8.00
	HC60	47.0	3.66	3.76	29.0	3.66	2.32	8.00
	HD60	47.0	3.66	3.76	29.0	3.66	2.32	8.00
	MC61	47.0	3.66	3.76	29.0	3.66	2.32	8.00
E1RD060S06	FC/MC/PC/UC60	58.0	3.52	4.83	35.0	2.32	4.42	8.00
	HC60	57.5	3.50	4.81	34.8	2.30	4.43	8.00
	HD60	58.0	3.52	4.83	35.0	2.32	4.42	8.00
	MC61	58.0	3.52	4.83	35.0	2.32	4.42	8.00
E1RD060S(25,46)	FC/MC/PC/UC60	57.0	3.66	4.56	34.4	3.66	2.75	8.00
	HC60	56.5	3.66	4.52	34.2	3.66	2.73	8.00
	HD60	57.0	3.66	4.56	34.4	3.66	2.75	8.00
	MC61	57.0	3.66	4.56	34.4	3.66	2.75	8.00

1. Rated CFM same as for cooling.

2. Heating MBH based on ARI standards of 70° DB entering indoor air, 72% RH outdoor air with 25 feet of interconnecting piping and no supplemental electric heat operation.

CP equals MBH output divided by (total KW input x 3.412).

HSPF (Heating Seasonal Performance Factor) is the total heating output during a normal annual usage period for heating divided by the total electric power input during the same period.

— = Not Applicable.

HEATING CAPACITY - With Variable Speed Furnaces

UNIT MODEL	VARIABLE SPEED FURNACE	COIL ¹ MODEL	ARI HEATING ²						
			47°F			17°F			HSPF
			MBH	COP	KW	MBH	COP	KW	STD
E1RD018S06	PV8*A12	FC/MC/PC18A	17.5	3.88	1.32	10.0	2.42	1.21	8.60
	PV9*A12	FC/MC/PC18A	17.6	3.82	1.35	10.1	2.40	1.23	8.40
	P(C,V)9*B12	FC/MC/PC18B	17.5	3.86	1.33	10.0	2.42	1.21	8.60
	PV9*A12	HC18	17.6	3.82	1.35	10.1	2.40	1.23	8.40
	PV8*A12	HC18	17.5	3.88	1.32	10.0	2.42	1.21	8.60
E1RD024S06	PV8*A12	FC/MC/PC24A	22.4	3.60	1.82	12.6	2.40	1.54	8.30
	PV9*A12	FC/MC/PC24A	22.4	3.60	1.82	12.6	2.40	1.54	8.30
	P(C,V)9*B12	FC/MC/PC24B	22.4	3.60	1.82	12.6	2.40	1.54	8.30
	PV8*A12	FC/MC/PC30A	22.4	3.60	1.82	12.6	2.40	1.54	8.30
	PV9*A12	FC/MC/PC30A	22.4	3.60	1.82	12.6	2.40	1.54	8.30
	P(C,V)9*B12	FC/MC/PC30B	22.4	3.60	1.82	12.6	2.40	1.54	8.30
	PV9*A12	HC30	23.0	3.42	1.97	13.0	2.28	1.67	8.00
	PV8*A12	HC30	23.0	3.42	1.97	13.0	2.28	1.67	8.00
E1RD030S06	PV8*B16	FC/MC/PC35B	29.6	3.84	2.32	15.6	2.32	1.97	8.20
	P(C,V)9*B12	FC/MC/PC35B	29.6	3.76	2.38	15.8	2.28	2.03	8.10
	PV8*C20	FC/MC/PC35C	29.6	3.86	2.29	15.6	2.32	1.96	8.20
	P(C,V)9*C16	FC/MC/PC35C	29.6	3.82	2.33	15.8	2.30	1.99	8.10
	PV8*B16	FC/MC/PC42B	29.6	3.84	2.32	15.6	2.32	1.97	8.20
	P(C,V)9*B12	FC/MC/PC42B	29.6	3.76	2.38	15.8	2.28	2.03	8.10
	PV8*C20	FC/MC/PC42C	29.6	3.86	2.29	15.6	2.32	1.96	8.20
	P(C,V)9*C16	FC/MC/PC42C	29.6	3.82	2.33	15.8	2.30	1.99	8.10
	PV8*B16	HC36	29.6	3.86	2.23	15.6	2.30	1.91	8.20
	PV8*C16	HC36	29.6	3.88	2.28	15.8	2.34	1.94	8.10
	PV8*C16	HD36	29.6	3.88	2.28	15.6	2.34	1.94	8.20
	P(C,V)9*C16	HD36	29.6	3.82	2.33	15.8	2.30	1.99	8.10
E1RD036S06	PV8*B16	FC/MC/PC35B	33.2	3.52	2.66	21.6	2.56	2.13	8.50
	P(C,V)9*B12	FC/MC/PC35B	33.2	3.56	2.63	21.6	2.58	2.10	8.50
	PV8*C16	FC/MC/PC35C	33.2	3.52	2.66	21.6	2.56	2.13	8.50
	PV8*C20	FC/MC/PC35C	33.2	3.56	2.63	21.6	2.58	2.10	8.50
	P(C,V)9*C16	FC/MC/PC35C	33.4	3.42	2.78	21.8	2.48	2.24	8.50
	P(C,V)9*C20	FC/MC/PC35C	33.4	3.52	2.66	21.8	2.56	2.13	8.50
	PV8*B16	FC/MC/PC42B	33.2	3.52	2.66	21.6	2.56	2.13	8.50
	P(C,V)9*B12	FC/MC/PC42B	33.2	3.56	2.63	21.6	2.58	2.10	8.50
	PV8*C16	FC/MC/PC42C	33.2	3.52	2.66	21.6	2.56	2.13	8.50
	PV8*C20	FC/MC/PC42C	33.2	3.56	2.63	21.6	2.58	2.10	8.50
	P(C,V)9*C16	FC/MC/PC42C	33.4	3.42	2.78	21.8	2.48	2.24	8.50
	P(C,V)9*C20	FC/MC/PC42C	33.4	3.52	2.66	21.8	2.56	2.13	8.50
	PV8*C20	FC/MC/PC48C	35.2	4.08	2.53	21.6	2.94	2.15	9.00
	P(C,V)9*C16	FC/MC/PC48C	35.4	4.04	2.57	21.8	2.92	2.19	9.00
	P(C,V)9*C20	FC/MC/PC48C	35.4	4.06	2.55	21.8	2.92	2.19	9.00
	P(C,V)9*D20	FC/MC/PC48D	35.4	4.06	2.55	21.8	2.92	2.19	9.00
	PV8*C20	HC42	34.2	4.00	2.45	21.6	2.88	2.08	8.50
	P(C,V)9*C16	HC42	34.4	4.00	2.45	21.8	2.88	2.08	8.50
	P(C,V)9*C20	HC42	34.4	3.82	2.59	21.8	2.76	2.21	8.50
	PV8*C20	HD36	34.6	4.08	2.47	21.6	2.94	2.09	8.50
P(C,V)9*C16	HD36	34.6	4.04	2.42	21.8	2.92	2.05	8.50	
P(C,V)9*C20	HD36	34.6	4.02	2.43	21.8	2.90	2.06	8.50	

For Notes See Page 16.

HEATING CAPACITY - With Variable Speed Furnaces (Continued)

UNIT MODEL	VARIABLE SPEED FURNACE	COIL ¹ MODEL	ARI HEATING ²						
			47°F			17°F			HSPF
			MBH	COP	KW	MBH	COP	KW	STD
E1RD042S06	PV8*C20	FC/MC/PC48C	41.5	3.70	3.29	24.6	2.62	2.75	8.75
	P(C,V)9*C16	FC/MC/PC48C	41.5	3.70	3.29	24.6	2.60	2.77	8.75
	P(C,V)9*C20	FC/MC/PC48C	41.0	3.76	3.19	24.2	2.66	2.67	8.75
	P(C,V)9*D20	FC/MC/PC48D	41.0	3.80	3.16	24.2	2.68	2.65	8.75
	PV8*C20	HD48	41.5	3.72	3.27	24.6	2.64	2.71	8.75
	P(C,V)9*C16	HD48	41.5	3.70	3.29	24.4	2.60	2.77	8.75
	P(C,V)9*C20	HD48	41.5	3.70	3.29	24.4	2.62	2.75	8.75
E1RD048S06	P(C,V)9*D20	FC/MC/PC60D	47.5	3.54	3.93	29.4	2.36	3.65	8.20
	PV8*C16	FC/PC60C	47.5	3.50	3.98	29.4	2.34	3.68	8.10
	PV8*C20	FC/PC60C	47.5	3.54	3.93	29.4	2.36	3.65	8.20
	P(C,V)9*C16	FC/PC60C	47.0	3.50	3.93	29.6	2.34	3.71	8.15
	P(C,V)9*C20	FC/PC60C	47.5	3.52	3.95	29.6	2.36	3.67	8.20
	P(C,V)9*C20	HC60	47.5	3.52	3.95	29.4	2.36	3.67	8.20
	PV8*C20	HD60	47.5	3.54	3.93	29.4	2.36	3.65	8.20
	P(C,V)9*C20	HD60	47.5	3.52	3.95	29.6	2.36	3.67	8.20
P(C,V)9*D20	MC61D	47.5	3.56	3.91	29.4	2.36	3.65	8.20	
E1RD060S06	P(C,V)9*D20	FC/MC/PC60D	56.0	3.56	4.61	34.0	2.34	4.26	8.15
	PV8*C20	FC/PC60C	57.5	3.54	4.76	34.6	2.32	4.37	8.10
	P(C,V)9*C20	FC/PC60C	57.0	3.52	4.83	34.2	2.32	4.32	8.10
	P(C,V)9*D20	HC60	56.0	3.56	4.65	34.0	2.32	4.29	8.15
	PV8*C20	HD60	56.0	3.54	4.76	34.0	2.32	4.34	8.15
	P(C,V)9*D20	HD60	56.0	3.56	4.65	34.0	2.34	4.26	8.15
	P(C,V)9*D20	MC61D	56.0	3.56	4.61	34.0	2.34	4.26	8.15

1. Rated CFM same as for cooling.

2. Heating MBH based on ARI standards of 70° DB entering indoor air, 72% RH outdoor air with 25 feet of interconnecting piping and no supplemental electric heat operation.

CP equals MBH output divided by (total KW input x 3.412).

HSPF (Heating Seasonal Performance Factor) is the total heating output during a normal annual usage period for heating divided by the total electric power input during the same period.

— = Not Applicable.

ACCESSORIES

Refer to Price Manual for specific model numbers.

Start Assist Kit (2SA067*)

Blower Time Delay - Available to increase efficiency when installed. Installs on indoor section and maintains blower for approximately one minute after cooling thermostat has been satisfied.

Hard Start Kits - Provides required starting torque for use with Thermal Expansion Valve Kit.

Low Temperature Cutout (2LT06700224) - Prevents heat pump operation below -10°F ambient temperature.

Compressor Blanket - Designed to further reduce the normal operating sound.

Add-on Fossil Fuel Control - Interface controls for use with gas, oil furnaces and the heat pump system are available.

Thermal Expansion Valve Kit - 1TVM700 Series TXV kit used to improve system performance.

Outdoor Thermostat (2TD06700124) - Provides additional staging of supplemental electric heat.

Room Thermostats - A wide selection of matching thermostats is available to provide features required for any installation.

2H/1C, manual changeover electronic non-programmable thermostat.

3H/2C, non-programmable digital thermostat.

3H/2C, auto/manual changeover, electronic programmable, 7-day, hardwire thermostat.

* For the most current accessory information, refer to the price book or consult factory.

SOUND POWER RATINGS

UNIT MODEL	(dBA)*	
	Cooling	Heating
018	70	70
024	74	75
030	76	77
036	76	77
042	77	78
048	78	78
060	79	79

* Rated in accordance with ARI 270-95 Standards.

INSTALLATION CLEARANCES

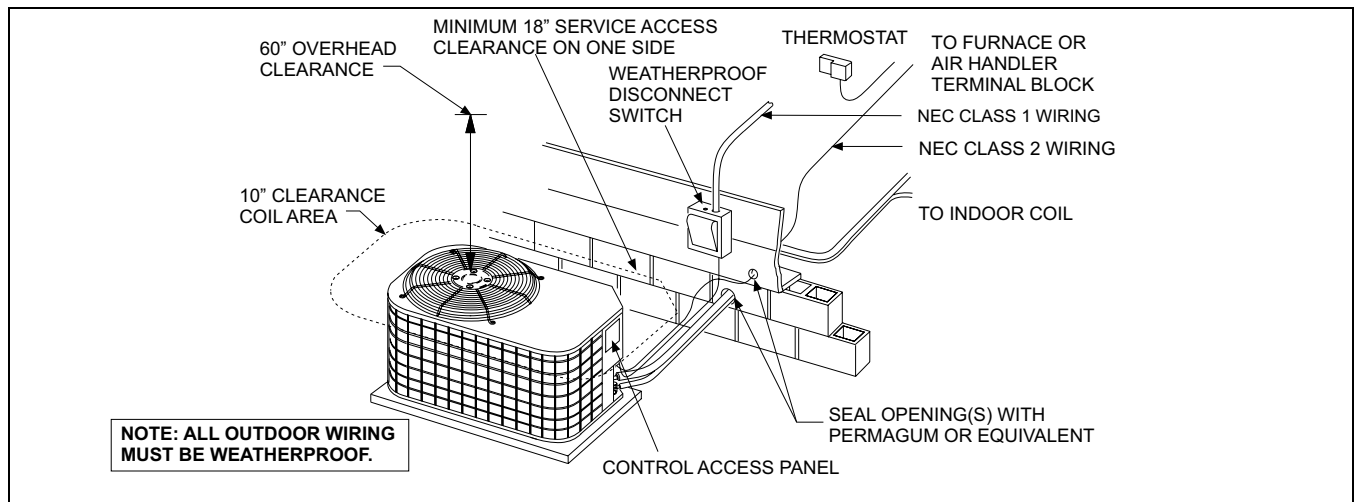

TYPICAL FIELD WIRING

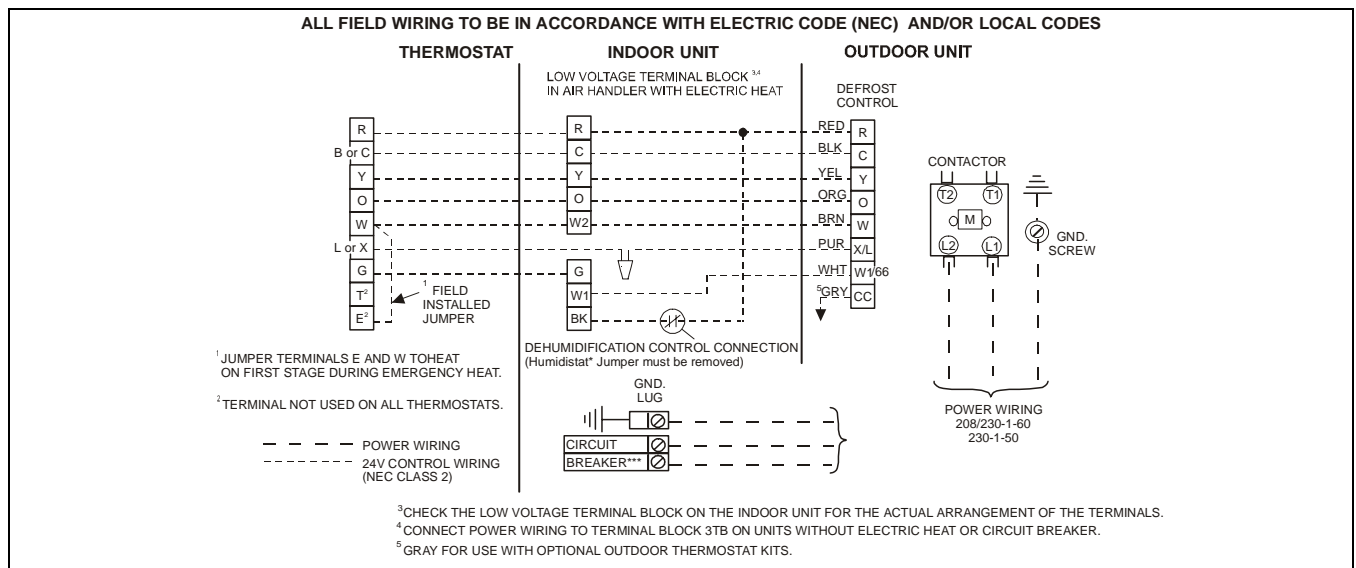

COOLING PERFORMANCE DATA																
OUTDOOR UNIT MODEL NO.		E1RD018S06														
INDOOR COIL MODEL NO.		FC/MC/PC/UC18														
CONDENSER ENTERING AIR TEMPERATURE	ID CFM	450					600					750				
	ID DB (°F)	80	80	75	80	80	80	80	75	80	80	80	80	75	80	80
	ID WB (°F)	57	62	62	67	72	57	62	62	67	72	57	62	62	67	72
65	T.C.	16.8	19.2	19.5	21.9	24.5	19.0	20.7	20.8	23.1	25.8	21.2	22.3	22.1	24.3	27.1
	S.C.	16.3	14.4	12.7	12.8	10.8	18.4	16.9	14.7	14.6	12.3	20.6	19.5	16.8	16.4	13.8
	K.W.	1.1	1.1	1.1	1.1	1.1	1.1	1.1	1.1	1.1	1.1	1.1	1.1	1.1	1.1	1.1
75	T.C.	16.1	18.1	18.3	20.6	23.2	18.1	19.5	19.4	21.8	24.3	20.1	20.9	20.6	23.0	25.4
	S.C.	15.6	13.9	12.1	12.3	10.3	17.6	16.3	14.1	14.0	11.7	19.5	18.8	16.0	15.8	13.0
	K.W.	1.2	1.2	1.2	1.2	1.2	1.2	1.2	1.2	1.2	1.2	1.2	1.2	1.2	1.2	1.3
85	T.C.	15.4	17.1	17.0	19.2	21.8	17.2	18.3	18.1	20.4	22.7	19.0	19.6	19.2	21.6	23.6
	S.C.	14.9	13.4	11.5	11.7	9.8	16.7	15.7	13.4	13.5	11.0	18.5	18.1	15.3	15.3	12.2
	K.W.	1.2	1.3	1.3	1.3	1.3	1.3	1.3	1.3	1.3	1.3	1.3	1.3	1.3	1.3	1.4
95	T.C.	14.8	16.0	15.8	17.9	20.4	16.3	17.1	16.8	19.1	21.2	17.9	18.3	17.7	20.3	21.9
	S.C.	14.2	12.9	10.9	11.1	9.3	15.8	15.1	12.7	12.9	10.4	17.5	17.4	14.6	14.7	11.4
	K.W.	1.3	1.3	1.3	1.4	1.4	1.4	1.4	1.4	1.4	1.4	1.4	1.4	1.4	1.4	1.5
105	T.C.	14.0	14.9	14.7	16.8	19.1	15.4	16.0	15.6	17.8	19.7	16.9	17.0	16.5	18.7	20.4
	S.C.	13.5	12.5	10.4	10.7	8.8	15.0	14.5	12.2	12.4	9.9	16.4	16.6	14.0	14.1	10.9
	K.W.	1.4	1.4	1.4	1.5	1.5	1.5	1.5	1.5	1.5	1.5	1.5	1.5	1.5	1.5	1.6
115	T.C.	13.3	13.9	13.7	15.7	17.8	14.5	14.9	14.5	16.4	18.4	15.8	15.8	15.3	17.2	19.0
	S.C.	12.8	12.0	9.9	10.2	8.3	14.1	13.9	11.7	11.8	9.4	15.4	15.8	13.4	13.4	10.5
	K.W.	1.5	1.5	1.5	1.6	1.6	1.5	1.6	1.5	1.6	1.6	1.6	1.6	1.6	1.6	1.7
125	T.C.	12.5	12.9	12.7	14.6	16.5	13.7	13.7	13.4	15.1	17.0	14.8	14.5	14.1	15.7	17.5
	S.C.	12.0	11.6	9.4	9.8	7.8	13.2	13.3	11.1	11.3	8.9	14.4	15.1	12.8	12.8	10.0
	K.W.	1.6	1.6	1.6	1.7	1.7	1.6	1.6	1.6	1.7	1.7	1.7	1.7	1.7	1.7	1.8

NOTE: ALL CAPACITIES ARE NET (KBTUH) WITH INDOOR FAN HEAT ALREADY DEDUCTED AT 1250 BTUH/1000 CFM.

Multipliers for determining the performance with other indoor sections.

NOTE: For dry bulb temperatures different than those listed (between 73-87 F), sensible capacity increases by 1060 BTUH per 1000 CFM per degree above the listed temperature and decreases by 1060 BTUH per 1000 CFM per degree below the listed temperature.

Air Handler	Coil	T.C.	S.C.	KW
MA08B	FC/MC18B	1.00	1.00	1.00
AHP18	—	1.00	0.92	1.00
F*FP024	—	1.00	0.92	1.00
MV12B	FC/MC18B	1.02	1.02	0.98
AV24	—	1.02	1.02	0.98
—	HC18	0.99	0.98	0.99

Variable Speed Furnace	Coil	T.C.	S.C.	KW
PV8*A12	FC/MC/PC18A	1.02	1.01	0.97
PV9*A12	FC/MC/PC18A	1.02	1.01	0.97
P(C,V)9*B12	FC/MC/PC18B	1.03	1.02	0.98
PV8*A12	HC18	1.02	1.01	0.97
PV9*A12	HC18	1.02	1.01	0.97

COOLING PERFORMANCE DATA																
OUTDOOR UNIT MODEL NO.		E1RD024S06														
INDOOR COIL MODEL NO.		FC/MC/PC/UC24														
CONDENSER ENTERING AIR TEMPERATURE	ID CFM	600					800					1000				
	ID DB (°F)	80	80	75	80	80	80	80	75	80	80	80	80	75	80	80
	ID WB (°F)	57	62	62	67	72	57	62	62	67	72	57	62	62	67	72
65	T.C.	21.1	25.4	23.3	29.6	29.1	23.5	27.6	25.0	29.9	29.8	25.9	29.8	26.7	30.2	30.4
	S.C.	21.1	18.5	15.7	17.0	13.6	23.5	23.0	19.1	19.9	14.3	25.9	27.5	22.4	22.7	15.1
	K.W.	1.3	1.4	1.4	1.4	1.3	1.4	1.4	1.4	1.4	1.3	1.4	1.4	1.3	1.4	1.3
75	T.C.	20.0	22.7	21.9	25.6	27.5	22.3	25.0	23.7	26.9	28.0	24.5	27.3	25.4	28.3	28.4
	S.C.	20.0	18.0	15.1	16.1	13.0	22.3	21.8	18.0	18.7	14.2	24.5	25.5	21.0	21.2	15.4
	K.W.	1.5	1.5	1.5	1.5	1.5	1.5	1.5	1.5	1.5	1.5	1.5	1.5	1.5	1.5	1.5
85	T.C.	19.0	20.0	20.5	21.6	26.0	21.1	22.3	22.3	24.0	27.0	23.2	24.7	24.2	26.4	28.1
	S.C.	19.0	17.6	14.5	15.2	12.4	21.1	20.5	17.0	17.5	14.1	23.2	23.5	19.5	19.7	15.8
	K.W.	1.6	1.6	1.6	1.6	1.7	1.6	1.6	1.6	1.6	1.7	1.6	1.6	1.7	1.7	1.7
95	T.C.	17.9	17.2	19.1	17.6	24.4	19.9	20.3	20.8	21.1	25.2	21.8	23.5	22.5	24.5	26.0
	S.C.	17.9	17.1	13.9	14.3	11.8	19.9	19.7	16.2	16.8	13.5	21.8	22.2	18.6	19.2	15.1
	K.W.	1.7	1.7	1.7	1.8	1.8	1.8	1.7	1.8	1.8	1.8	1.8	1.8	1.8	1.8	1.8
105	T.C.	16.9	16.8	17.6	17.4	22.5	18.7	19.5	19.2	20.1	23.2	20.5	22.2	20.7	22.7	23.8
	S.C.	16.9	16.2	13.0	13.7	11.3	18.7	18.5	15.4	16.2	12.9	20.5	20.9	17.8	18.7	14.4
	K.W.	1.8	1.8	1.8	1.9	2.0	1.9	1.9	1.9	1.9	2.0	1.9	1.9	1.9	1.9	2.0
115	T.C.	16.0	16.4	16.2	17.3	20.7	17.6	18.7	17.6	19.1	21.2	19.2	21.0	19.1	20.9	21.7
	S.C.	16.0	15.3	12.2	13.2	10.8	17.6	17.5	14.6	15.7	12.3	19.2	19.6	17.0	18.3	13.8
	K.W.	2.0	2.0	1.9	2.0	2.1	2.0	2.0	2.0	2.1	2.1	2.1	2.1	2.0	2.1	2.2
125	T.C.	15.0	16.0	14.8	17.1	18.9	16.4	17.9	16.1	18.1	19.2	17.9	19.7	17.4	19.2	19.6
	S.C.	15.0	14.5	11.5	12.6	10.2	16.4	16.4	13.8	15.2	11.7	17.9	18.3	16.2	17.8	13.1
	K.W.	2.1	2.1	2.1	2.2	2.3	2.1	2.1	2.1	2.2	2.3	2.2	2.2	2.2	2.2	2.3

NOTE: ALL CAPACITIES ARE NET (KBTUH) WITH INDOOR FAN HEAT ALREADY DEDUCTED AT 1250 BTUH/1000 CFM.

Multipliers for determining the performance with other indoor sections.

NOTE: For dry bulb temperatures different than those listed (between 73-87 F), sensible capacity increases by 1060 BTUH per 1000 CFM per degree above the listed temperature and decreases by 1060 BTUH per 1000 CFM per degree below the listed temperature.

Air Handler	Coil	T.C.	S.C.	KW
MA08B	FC/MC24B	1.00	1.01	1.00
MA08B	FC/MC30B	1.00	1.01	1.00
AHP24	–	0.99	0.98	0.99
F*FP030	–	1.00	0.98	1.00
MV12B	FC/MC24B	1.02	1.00	0.97
MV12B	FC/MC30B	1.02	1.00	0.97
AV24	–	1.02	1.00	0.97
–	FC/MC/PC/UC30	1.00	1.00	1.00
–	HC30	1.01	0.99	1.01
–	HD24	1.00	1.00	1.00

Variable Speed Furnace	Coil	T.C.	S.C.	KW
PV8*A12	FC/MC/PC24A	1.00	1.00	0.96
PV9*A12	FC/MC/PC24A	1.00	1.00	0.96
P(C,V)9*B12	FC/MC/PC24B	1.00	0.99	0.96
PV8*A12	FC/MC/PC30A	1.00	1.00	0.96
PV9*A12	FC/MC/PC30A	1.00	1.00	0.96
P(C,V)9*B12	FC/MC/PC30B	1.00	1.03	0.96
PV8*A12	HC30	1.00	1.03	0.96
PV9*A12	HC30	1.00	1.01	0.96
PV8*A12	HD30	1.00	1.01	0.96
PV9*A12	HD30	1.00	1.01	0.96

COOLING PERFORMANCE DATA																
OUTDOOR UNIT MODEL NO.		E1RD030S06, E1RD030S(25,46)**														
INDOOR COIL MODEL NO.		FC/MC/PC35														
CONDENSER ENTERING AIR TEMPERATURE	ID CFM	800					1000					1200				
	ID DB (°F)	80	80	75	80	80	80	80	75	80	80	80	80	75	80	80
	ID WB (°F)	57	62	62	67	72	57	62	62	67	72	57	62	62	67	72
65	T.C.	28.5	31.9	31.9	34.8	34.4	30.7	32.7	34.5	34.2	33.7	32.9	33.5	37.2	33.6	33.9
	S.C.	28.4	26.0	22.0	21.8	16.6	30.6	27.9	25.7	21.2	16.9	32.9	29.8	29.3	20.7	17.3
	K.W.	1.8	1.9	1.9	1.9	1.9	1.9	1.9	1.9	1.9	1.9	1.9	1.9	1.9	1.9	1.9
75	T.C.	27.0	29.7	29.6	32.7	33.8	29.1	30.6	31.6	32.6	33.4	31.2	31.5	33.6	32.4	33.0
	S.C.	26.9	25.1	21.2	21.1	16.5	29.0	27.2	24.4	21.6	17.2	31.1	29.4	27.5	22.1	17.9
	K.W.	2.0	2.0	2.0	2.0	2.0	2.0	2.0	2.0	2.0	2.1	2.0	2.0	2.0	2.0	2.1
85	T.C.	25.4	27.6	27.2	30.7	33.2	27.4	28.5	28.6	31.0	33.2	29.4	29.5	30.0	31.2	33.1
	S.C.	25.4	24.1	20.4	20.4	16.5	27.4	26.6	23.1	22.0	17.5	29.4	29.0	25.8	23.6	18.5
	K.W.	2.1	2.2	2.2	2.2	2.2	2.2	2.2	2.2	2.2	2.3	2.2	2.2	2.2	2.2	2.3
95	T.C.	23.9	25.5	24.8	28.6	32.6	25.8	26.5	25.6	29.3	32.9	27.7	27.5	26.5	30.0	33.2
	S.C.	23.9	23.2	19.6	19.7	16.4	25.7	25.9	21.8	22.4	17.8	27.6	28.6	24.0	25.0	19.1
	K.W.	2.3	2.3	2.3	2.4	2.4	2.3	2.3	2.3	2.4	2.4	2.4	2.4	2.4	2.4	2.5
105	T.C.	22.5	23.6	22.9	26.2	29.8	24.1	24.6	23.8	26.8	30.1	25.7	25.5	24.6	27.3	30.3
	S.C.	22.4	22.1	18.6	18.9	15.4	24.0	24.2	20.9	21.4	16.8	25.6	26.4	23.2	23.9	18.2
	K.W.	2.5	2.5	2.5	2.5	2.6	2.5	2.5	2.5	2.6	2.6	2.6	2.6	2.5	2.6	2.6
115	T.C.	21.0	21.8	21.0	23.9	27.1	22.4	22.7	21.9	24.3	27.3	23.8	23.6	22.9	24.7	27.6
	S.C.	21.0	21.0	17.6	18.2	14.5	22.3	22.6	20.1	20.5	15.9	23.7	24.2	22.5	22.8	17.2
	K.W.	2.6	2.6	2.6	2.7	2.8	2.7	2.7	2.6	2.7	2.8	2.7	2.7	2.7	2.7	2.8
125	T.C.	19.6	19.9	19.1	21.5	24.3	20.7	20.8	20.1	21.8	24.5	21.8	21.7	21.1	22.1	24.8
	S.C.	19.5	19.9	16.7	17.4	13.6	20.6	20.9	19.2	19.5	14.9	21.7	22.0	21.7	21.7	16.3
	K.W.	2.8	2.8	2.8	2.9	3.0	2.9	2.9	2.8	2.9	3.0	2.9	2.9	2.8	2.9	3.0

NOTE: ALL CAPACITIES ARE NET (KBTUH) WITH INDOOR FAN HEAT ALREADY DEDUCTED AT 1250 BTUH/1000 CFM.
** For three-phase, decrease T.C. by 1.0 and S.C. by 0.7.

Multipliers for determining the performance with other indoor sections.

NOTE: For dry bulb temperatures different than those listed (between 73-87 F), sensible capacity increases by 1060 BTUH per 1000 CFM per degree above the listed temperature and decreases by 1060 BTUH per 1000 CFM per degree below the listed temperature.

Air Handler	Coil	T.C.	S.C.	KW
MA12B	FC/MC35B	1.00	1.00	1.00
MA12B	FC/MC42B	1.00	1.00	1.00
AHP30	—	1.00	0.97	1.00
F*FP040	—	0.99	0.97	0.99
MV12B*	FC/MC35B	1.02	1.00	0.98
MV12B*	FC/MC42B	1.02	1.00	0.98
MV16C*	FC/MC35C	1.02	1.00	0.98
MV16C*	FC/MC42C	1.02	1.00	0.98
AV36*	—	1.02	1.00	0.98
—	FC/MC/PC/UC42	1.00	1.00	1.00
—	HC36	0.99	0.97	0.99
—	HD36	1.01	1.00	1.01

* = Single-phase outdoor units only.

Variable Speed Furnace *	Coil	T.C.	S.C.	KW
PV8*B16	FC/MC/PC35B	1.02	1.01	0.98
P(C,V)9*B12	FC/MC/PC35B	1.02	1.01	0.98
PV8*C16	FC/MC/PC35C	1.02	1.00	0.98
P(C,V)9*C16	FC/MC/PC35C	1.02	1.01	0.98
PV8*B16	FC/MC/PC42B	1.02	1.01	0.98
P(C,V)9*B12	FC/MC/PC42B	1.02	1.01	0.98
PV8*C16	FC/MC/PC42C	1.02	1.00	0.98
P(C,V)9*C16	FC/MC/PC42C	1.02	1.01	0.98
PV8*B16	HC36	1.02	1.01	0.98
P(C,V)9*B12	HC36	1.02	1.01	0.98
PV8*B16	HD36	1.02	1.01	0.98
P(C,V)9*B12	HD36	1.02	1.01	0.98

* = Single-phase outdoor units only.

COOLING PERFORMANCE DATA																
OUTDOOR UNIT MODEL NO.		E1RD036S06, E1RD036S(25,46)**														
INDOOR COIL MODEL NO.		FC/MC/PC/UC48														
CONDENSER ENTERING AIR TEMPERATURE	ID CFM	1000					1200					1400				
	ID DB (°F)	80	80	75	80	80	80	80	75	80	80	80	80	75	80	80
	ID WB (°F)	57	62	62	67	72	57	62	62	67	72	57	62	62	67	72
65	T.C.	35.0	37.8	37.5	41.8	46.7	37.1	39.1	38.7	43.0	47.4	39.1	40.4	39.9	44.2	48.1
	S.C.	33.9	31.5	26.9	26.8	22.0	36.0	34.7	29.4	29.0	23.8	38.1	37.9	31.8	31.3	25.5
	K.W.	1.9	1.9	1.9	1.9	1.9	1.9	1.9	1.9	1.9	1.9	1.9	1.9	1.9	1.9	1.9
75	T.C.	33.5	35.8	35.6	39.6	44.3	35.4	37.0	36.8	40.7	45.2	37.4	38.2	37.9	41.8	46.0
	S.C.	32.4	30.5	26.0	26.0	21.2	34.4	33.5	28.4	28.2	22.9	36.4	36.5	30.8	30.5	24.6
	K.W.	2.1	2.1	2.1	2.1	2.1	2.1	2.1	2.1	2.1	2.1	2.1	2.1	2.1	2.1	2.2
85	T.C.	32.0	33.8	33.8	37.4	41.9	33.8	34.9	34.9	38.4	42.9	35.6	36.0	36.0	39.4	43.8
	S.C.	31.0	29.5	25.1	25.1	20.3	32.8	32.3	27.5	27.4	22.0	34.7	35.1	29.8	29.8	23.7
	K.W.	2.3	2.3	2.3	2.3	2.4	2.3	2.3	2.3	2.3	2.4	2.3	2.3	2.3	2.3	2.4
95	T.C.	30.5	31.8	31.9	35.1	39.6	32.1	32.8	33.0	36.1	40.6	33.8	33.8	34.1	37.0	41.7
	S.C.	29.5	28.4	24.3	24.2	19.5	31.2	31.1	26.6	26.6	21.2	33.0	33.7	28.8	29.0	22.8
	K.W.	2.4	2.5	2.5	2.5	2.6	2.5	2.5	2.5	2.5	2.6	2.5	2.5	2.5	2.5	2.6
105	T.C.	29.0	29.9	29.8	32.9	36.9	30.5	30.8	30.8	33.7	37.8	31.9	31.7	31.7	34.5	38.7
	S.C.	28.1	27.5	23.4	23.3	18.6	29.6	29.7	25.7	25.7	20.2	31.2	31.9	28.0	28.0	21.8
	K.W.	2.7	2.7	2.7	2.7	2.8	2.7	2.7	2.7	2.7	2.8	2.7	2.7	2.7	2.8	2.8
115	T.C.	27.7	28.0	27.9	30.7	34.2	28.9	28.9	28.6	31.3	35.0	30.1	29.8	29.3	32.0	35.8
	S.C.	26.8	26.6	22.6	22.4	17.7	28.1	28.4	24.9	24.7	19.2	29.4	30.2	27.1	27.0	20.8
	K.W.	2.9	2.9	2.8	2.9	3.0	2.9	2.9	2.9	3.0	3.0	3.0	2.9	2.9	3.0	3.1
125	T.C.	26.3	26.1	25.9	28.5	31.6	27.3	27.0	26.4	29.0	32.3	28.3	27.8	27.0	29.5	32.9
	S.C.	25.5	25.7	21.8	21.5	16.8	26.6	27.1	24.0	23.8	18.3	27.6	28.4	26.3	26.0	19.8
	K.W.	3.1	3.1	3.0	3.1	3.2	3.1	3.1	3.1	3.2	3.3	3.2	3.2	3.1	3.2	3.3

NOTE: ALL CAPACITIES ARE NET (KBTUH) WITH INDOOR FAN HEAT ALREADY DEDUCTED AT 1250 BTUH/1000 CFM.
 ** For three-phase, decrease T.C. by 1.0 and S.C. by 0.7.

Multipliers for determining the performance with other indoor sections

NOTE: For dry bulb temperatures different than those listed (between 73-87 F), sensible capacity increases by 1060 BTUH per 1000 CFM per degree above the listed temperature and decreases by 1060 BTUH per 1000 CFM per degree below the listed temperature.

Air Handler	Coil	T.C.	S.C.	KW
MA12B	FC/MC35B	0.99	0.99	0.99
MA12B	FC/MC42B	0.99	0.99	0.99
MA16C	FC/MC35C	0.99	0.99	0.99
MA16C	FC/MC42C	0.99	0.99	0.99
MA14D	FC/MC48D	1.00	1.00	1.00
AHP36	-	0.98	0.99	0.98
F*FP040	-	0.99	0.99	0.99
F*FP042	-	0.99	0.99	0.99
MV16C*	FC/MC35C	1.01	0.98	0.97
MV16C*	FC/MC42C	1.01	0.98	0.97
MV16C*	FC/MC48C	1.01	0.98	0.97
MV20D*	FC/MC48D	1.01	0.98	0.97
AV36*	-	1.01	0.98	0.97
-	FC/MC/PC/35	0.99	0.99	0.99
-	FC/MC/PC/UC42	0.99	0.99	0.99
-	HC42	0.98	0.96	0.98
-	HD36	0.98	0.98	0.98

* = Single-phase outdoor units only.

Variable Speed Furnace *	Coil	T.C.	S.C.	KW
PV8*B16	FC/MC/PC35B	1.01	1.00	0.96
P(C,V)9*B12	FC/MC/PC35B	1.01	1.00	0.96
PV8*C16	FC/MC/PC35C	1.01	1.00	0.96
PV8*C20	FC/MC/PC35C	1.01	1.00	0.96
P(C,V)9*C16	FC/MC/PC35C	1.00	1.00	1.00
P(C,V)9*C20	FC/MC/PC35C	1.00	0.99	0.96
PV8*B16	FC/MC/PC42B	1.01	1.00	0.96
P(C,V)9*B12	FC/MC/PC42B	1.01	1.00	0.96
PV8*C16	FC/MC/PC42C	1.01	1.00	0.96
PV8*C20	FC/MC/PC42C	1.01	1.00	0.96
P(C,V)9*C16	FC/MC/PC42C	1.00	1.00	1.00
P(C,V)9*C20	FC/MC/PC42C	1.00	0.99	0.96
PV8*C20	FC/MC/PC48C	1.01	1.00	0.97
P(C,V)9*C16	FC/MC/PC48C	1.01	1.00	0.97
P(C,V)9*C20	FC/MC/PC48C	1.01	0.99	0.97
P(C,V)9*D20	FC/MC/PC48D	1.01	1.00	0.97
PV8*C20	HC42	1.01	0.99	0.96
P(C,V)9*C16	HC42	1.00	1.00	1.00
P(C,V)9*C20	HC42	1.00	1.00	0.96
PV8*C20	HD36	1.01	1.01	0.96
P(C,V)9*C16	HD36	1.00	1.00	1.00
P(C,V)9*C20	HD36	1.00	1.00	0.96

* = Single-phase outdoor units only.

COOLING PERFORMANCE DATA																
OUTDOOR UNIT MODEL NO.		E1RD042S06, E1RD042S(25,46)**														
INDOOR COIL MODEL NO.		FC/MC/PC/UC48														
CONDENSER ENTERING AIR TEMPERATURE	ID CFM	1200					1400					1600				
	ID DB (°F)	80	80	75	80	80	80	80	75	80	80	80	80	75	80	80
	ID WB (°F)	57	62	62	67	72	57	62	62	67	72	57	62	62	67	72
65	T.C.	38.3	43.6	41.6	46.5	49.4	40.5	44.8	42.8	47.6	50.2	42.7	46.1	44.0	48.7	50.9
	S.C.	38.3	36.8	30.3	31.3	24.1	40.5	39.8	32.7	33.6	25.5	42.7	42.9	35.1	35.8	27.0
	K.W.	2.4	2.4	2.4	2.4	2.4	2.4	2.4	2.4	2.4	2.5	2.4	2.4	2.4	2.4	2.5
75	T.C.	37.0	41.4	39.7	44.3	47.0	39.0	42.8	40.8	45.3	47.4	41.0	44.3	41.9	46.3	47.9
	S.C.	37.0	35.8	29.5	30.3	23.7	39.0	38.7	31.9	32.6	25.2	41.0	41.5	34.3	34.9	26.7
	K.W.	2.6	2.6	2.6	2.6	2.7	2.6	2.6	2.6	2.7	2.7	2.6	2.6	2.6	2.7	2.7
85	T.C.	35.6	39.3	37.9	42.1	44.6	37.4	40.9	38.8	43.1	44.7	39.3	42.4	39.7	44.0	44.8
	S.C.	35.6	34.8	28.8	29.3	23.4	37.4	37.5	31.1	31.6	24.9	39.3	40.1	33.4	34.0	26.5
	K.W.	2.8	2.8	2.8	2.9	2.9	2.8	2.9	2.8	2.9	2.9	2.9	2.9	2.8	2.9	3.0
95	T.C.	34.2	37.2	36.0	40.0	42.2	35.9	38.9	36.8	41.0	42.0	37.6	40.5	37.6	41.6	41.8
	S.C.	34.2	33.8	28.0	28.3	23.0	35.9	36.3	30.3	30.8	24.6	37.6	38.8	32.6	33.0	26.3
	K.W.	3.0	3.1	3.0	3.1	3.2	3.1	3.1	3.0	3.1	3.2	3.1	3.1	3.1	3.2	3.2
105	T.C.	32.4	35.2	33.6	37.3	39.4	34.2	36.8	34.3	38.0	39.4	36.1	38.4	35.1	38.7	39.4
	S.C.	32.4	32.2	26.7	27.1	21.7	34.2	34.3	28.9	29.4	23.3	35.8	36.4	31.2	31.6	24.9
	K.W.	3.3	3.3	3.2	3.3	3.4	3.3	3.3	3.3	3.4	3.5	3.4	3.4	3.3	3.4	3.5
115	T.C.	30.6	33.2	31.2	34.7	36.7	32.6	34.7	32.0	35.4	36.9	34.6	36.3	32.7	36.0	37.1
	S.C.	30.6	30.6	25.5	26.0	20.5	32.3	32.3	27.6	28.1	22.0	33.7	34.0	29.8	30.2	23.6
	K.W.	3.5	3.5	3.5	3.6	3.7	3.5	3.6	3.5	3.6	3.7	3.6	3.6	3.5	3.6	3.7
125	T.C.	28.8	31.2	28.8	32.1	33.9	31.0	32.7	29.6	32.7	34.3	33.1	34.2	30.3	33.3	34.7
	S.C.	28.8	29.1	24.3	24.8	19.2	30.3	30.4	26.3	26.8	20.7	31.7	31.7	28.4	28.9	22.2
	K.W.	3.7	3.7	3.7	3.8	4.0	3.8	3.8	3.7	3.8	4.0	3.8	3.8	3.7	3.9	4.0

NOTE: ALL CAPACITIES ARE NET (KBTUH) WITH INDOOR FAN HEAT ALREADY DEDUCTED AT 1250 BTUH/1000 CFM.
** For three-phase, decrease T.C. by 1.0 and S.C. by 0.7.

Multipliers for determining the performance with other indoor sections.

NOTE: For dry bulb temperatures different than those listed (between 73-87 F), sensible capacity increases by 1060 BTUH per 1000 CFM per degree above the listed temperature and decreases by 1060 BTUH per 1000 CFM per degree below the listed temperature.

Air Handler	Coil	T.C.	S.C.	KW
MA14D	FC/MC48D	1.00	1.00	1.00
MA16C	FC/MC48C	1.00	1.00	1.00
AHP/SHP48	—	1.00	1.00	1.00
MV16C*	FC/MC48C	1.00	0.98	1.00
MV20D*	FC/MC48D	1.01	0.99	0.97
AV/SV48*	—	1.01	0.99	0.97
—	HD48	0.99	0.98	0.99

* = Single-phase outdoor units only.

Variable Speed Furnace *	Coil	T.C.	S.C.	KW
PV8*C20	FC/MC/PC48C	1.00	1.00	1.00
P(C,V)9*C16	FC/MC/PC48C	1.00	1.00	1.00
P(C,V)9*C20	FC/MC/PC48C	1.00	1.00	1.00
P(C,V)9*D20	FC/MC/PC48D	1.00	1.00	1.00
PV8*C20	HD48	0.98	0.98	0.98
P(C,V)9*C16	HD48	0.99	0.99	0.99
P(C,V)9*C20	HD48	0.98	0.98	0.98

* = Single-phase outdoor units only.

COOLING PERFORMANCE DATA																
OUTDOOR UNIT MODEL NO.		E1RD048S06, E1RD048S(25,46)**														
INDOOR COIL MODEL NO.		FC/MC/PC/UC60														
CONDENSER ENTERING AIR TEMPERATURE	ID CFM	1400					1600					1800				
	ID DB (°F)	80	80	75	80	80	80	80	75	80	80	80	80	75	80	80
	ID WB (°F)	57	62	62	67	72	57	62	62	67	72	57	62	62	67	72
65	T.C.	43.2	47.1	45.4	49.6	51.0	46.2	48.0	45.8	49.7	51.3	49.2	48.8	46.2	49.7	51.6
	S.C.	42.7	41.7	34.8	34.3	26.0	43.8	43.3	37.1	36.6	27.7	44.8	44.8	39.4	38.8	29.5
	K.W.	2.4	2.4	2.4	2.4	2.4	2.4	2.4	2.4	2.4	2.4	2.4	2.4	2.4	2.4	2.4
75	T.C.	43.1	45.5	43.5	47.8	49.9	45.7	46.6	44.0	48.2	50.2	48.3	47.7	44.5	48.6	50.5
	S.C.	41.4	40.6	33.9	33.7	25.8	42.6	42.2	36.2	36.0	27.4	43.8	43.7	38.5	38.2	29.0
	K.W.	2.7	2.7	2.7	2.7	2.7	2.7	2.7	2.7	2.7	2.7	2.7	2.7	2.7	2.7	2.7
85	T.C.	42.9	43.8	41.6	46.1	48.9	45.2	45.2	42.2	46.8	49.1	47.4	46.5	42.8	47.4	49.3
	S.C.	40.1	39.5	33.1	33.1	25.6	41.5	41.0	35.3	35.4	27.1	42.8	42.6	37.5	37.7	28.6
	K.W.	3.0	3.0	3.0	3.0	3.0	3.0	3.0	3.0	3.0	3.0	3.0	3.0	3.0	3.0	3.0
95	T.C.	42.8	42.1	39.7	44.3	47.9	44.7	43.8	40.4	46.0	48.0	46.5	45.4	41.1	46.3	48.2
	S.C.	38.9	38.4	32.2	32.5	25.4	40.4	39.9	34.4	35.4	26.8	41.9	41.4	36.6	37.2	28.1
	K.W.	3.3	3.3	3.3	3.3	3.3	3.3	3.3	3.3	3.4	3.4	3.3	3.3	3.3	3.3	3.3
105	T.C.	40.5	40.2	37.6	42.1	45.0	42.6	41.8	38.2	42.9	45.4	44.7	43.4	38.8	43.7	45.7
	S.C.	37.1	36.7	31.2	31.7	24.5	38.5	38.2	33.2	34.0	25.9	40.0	39.6	35.2	36.3	27.3
	K.W.	3.7	3.7	3.7	3.7	3.7	3.7	3.7	3.7	3.7	3.7	3.7	3.7	3.7	3.7	3.7
115	T.C.	38.2	38.3	35.5	40.0	42.2	40.6	39.9	36.0	40.6	42.8	43.0	41.4	36.6	41.2	43.3
	S.C.	35.4	35.1	30.3	30.9	23.5	36.8	36.5	32.1	33.2	25.0	38.1	37.8	33.9	35.5	26.5
	K.W.	4.1	4.1	4.1	4.1	4.1	4.2	4.1	4.1	4.1	4.1	4.2	4.1	4.1	4.1	4.1
125	T.C.	35.9	36.5	33.4	37.9	39.4	38.6	37.9	33.9	38.3	40.2	41.3	39.4	34.4	38.8	40.9
	S.C.	33.7	33.5	29.4	30.2	22.6	35.0	34.8	31.0	32.4	24.1	36.3	36.1	32.6	34.7	25.7
	K.W.	4.6	4.5	4.5	4.5	4.5	4.6	4.5	4.5	4.5	4.6	4.6	4.5	4.5	4.5	4.6

NOTE: ALL CAPACITIES ARE NET (KBTUH) WITH INDOOR FAN HEAT ALREADY DEDUCTED AT 1250 BTUH/1000 CFM.
 ** For three-phase, decrease T.C. by 1.0 and S.C. by 0.7.

Multipliers for determining the performance with other indoor sections.

NOTE: For dry bulb temperatures different than those listed (between 73-87 F), sensible capacity increases by 1060 BTUH per 1000 CFM per degree above the listed temperature and decreases by 1060 BTUH per 1000 CFM per degree below the listed temperature

Air Handler	Coil	T.C.	S.C.	KW
MA16C	FC60C	1.00	1.00	1.00
MA20D	FC/MC60D	1.00	1.00	1.00
MA20D	MC61D	1.00	1.00	1.00
AHP/SHP48	–	1.00	1.00	1.00
AHP/SHP60	–	1.00	0.98	1.00
F*FV060*	–	1.00	0.98	0.92
MV20D*	FC/MC60D	1.00	0.98	1.00
MV20D*	MC61D	1.01	0.98	1.01
AV/SV48*	–	1.01	0.98	1.01
–	HC60	0.99	0.97	0.99
–	HD60	0.98	0.98	0.98
–	MC61	1.00	1.00	1.00

* = Single-phase outdoor units only.

Variable Speed Furnace *	Coil	T.C.	S.C.	KW
P(C,V)9*D20	FC/MC/PC60D	1.00	1.00	1.00
PV8*C16	FC/PC60C	0.99	0.99	0.99
PV8*C20	FC/PC60C	1.00	1.00	1.00
P(C,V)9*C16	FC/PC60C	1.00	1.00	1.00
P(C,V)9*C20	FC/PC60C	1.00	0.97	1.00
P(C,V)9*D20	HC60	1.00	1.00	1.00
PV8*C20	HD60	1.00	1.00	1.00
P(C,V)9*C20	HD60	1.00	0.98	1.00
P(C,V)9*D20	MC61D	1.01	0.99	1.01

* = Single-phase outdoor units only.

COOLING PERFORMANCE DATA																
OUTDOOR UNIT MODEL NO.		E1RD060S06, E1RD060S(25,46)**														
INDOOR COIL MODEL NO.		FC/MC/PC/UC60														
CONDENSER ENTERING AIR TEMPERATURE	ID CFM	1600					1800					2000				
	ID DB (°F)	80	80	75	80	80	80	80	75	80	80	80	80	75	80	80
	ID WB (°F)	57	62	62	67	72	57	62	62	67	72	57	62	62	67	72
65	T.C.	47.8	51.8	54.4	58.7	65.2	49.3	52.9	55.5	60.2	66.6	50.8	54.1	56.6	61.7	68.0
	S.C.	47.8	47.1	41.0	40.0	31.0	49.3	50.2	44.0	43.0	32.6	50.8	53.4	46.9	46.0	34.3
	K.W.	2.9	2.9	2.9	2.9	2.9	2.9	2.9	2.9	2.9	3.0	2.9	2.9	2.9	2.9	3.0
75	T.C.	47.0	50.3	52.6	57.1	63.0	48.7	51.4	53.7	58.5	64.3	50.4	52.5	54.8	59.8	65.6
	S.C.	47.0	46.5	40.2	39.4	30.6	48.7	49.6	43.2	42.4	32.3	50.4	52.5	46.1	45.3	33.9
	K.W.	3.3	3.3	3.3	3.3	3.4	3.3	3.3	3.3	3.3	3.4	3.3	3.3	3.3	3.3	3.4
85	T.C.	46.1	48.8	50.8	55.6	60.9	48.1	49.8	51.8	56.7	62.1	50.0	50.8	52.9	57.9	63.3
	S.C.	46.1	45.9	39.4	38.9	30.3	48.1	49.0	42.4	41.7	31.9	50.0	50.8	45.3	44.6	33.6
	K.W.	3.7	3.7	3.7	3.7	3.8	3.7	3.7	3.7	3.8	3.8	3.7	3.7	3.7	3.8	3.8
95	T.C.	45.3	47.3	48.9	54.0	58.7	47.4	48.2	50.0	55.0	59.8	49.6	49.1	51.1	55.9	60.9
	S.C.	45.3	45.2	38.6	38.3	29.9	47.4	48.2	41.6	41.1	31.6	49.6	49.1	44.6	43.9	33.2
	K.W.	4.1	4.1	4.1	4.2	4.2	4.1	4.1	4.1	4.2	4.2	4.1	4.2	4.1	4.2	4.2
105	T.C.	43.1	44.3	45.5	50.3	55.9	45.1	45.2	46.4	51.2	56.9	47.1	46.1	47.3	52.0	57.9
	S.C.	43.1	43.1	36.8	36.5	28.6	45.1	45.2	39.5	39.2	30.3	47.1	46.1	42.3	42.0	31.9
	K.W.	4.6	4.7	4.7	4.7	4.8	4.7	4.7	4.7	4.7	4.8	4.7	4.7	4.7	4.8	4.8
115	T.C.	40.9	41.4	42.3	46.8	53.1	42.8	42.3	43.0	47.5	54.0	44.7	43.2	43.7	48.2	55.0
	S.C.	40.9	41.1	35.0	34.8	27.3	42.8	42.3	37.6	37.4	29.0	44.7	43.2	40.2	40.1	30.7
	K.W.	5.2	5.3	5.2	5.3	5.4	5.2	5.3	5.3	5.3	5.4	5.2	5.3	5.3	5.3	5.4
125	T.C.	38.8	38.6	39.0	43.2	50.3	40.6	39.4	39.5	43.8	51.2	42.3	40.2	40.0	44.4	52.1
	S.C.	38.8	38.6	33.2	33.1	26.0	40.6	39.4	35.6	35.7	27.7	42.3	40.2	38.0	38.2	29.4
	K.W.	5.7	5.8	5.8	5.9	5.9	5.8	5.8	5.8	5.9	6.0	5.8	5.9	5.8	5.9	6.0

NOTE: ALL CAPACITIES ARE NET (KBTUH) WITH INDOOR FAN HEAT ALREADY DEDUCTED AT 1250 BTUH/1000 CFM.
** For three-phase, decrease T.C. by 1.0 and S.C. by 0.7.

Multipliers for determining the performance with other indoor sections.

NOTE: For dry bulb temperatures different than those listed (between 73-87 F), sensible capacity increases by 1060 BTUH per 1000 CFM per degree above the listed temperature and decreases by 1060 BTUH per 1000 CFM per degree below the listed temperature.

Air Handler	Coil	T.C.	S.C.	KW
MA20D	FC/MC60D	1.00	1.00	1.00
MA20D	MC61D	1.01	1.01	1.01
AHP/SHP60	—	1.00	0.98	1.00
F*FV060*	—	0.98	0.98	0.98
MV20D*	FC/MC60D	0.98	0.98	0.98
MV20D*	MC61D	1.00	0.98	1.00
AV/SV60*	—	1.00	0.98	1.00
—	HC60	0.99	0.98	0.99
—	HD60	0.98	0.98	0.98
—	MC61	1.01	1.01	1.01

* = Single-phase outdoor units only.

Variable Speed Furnace *	Coil	T.C.	S.C.	KW
P(C,V)9*D20	FC/MC/PC60D	0.99	0.95	0.99
PV8*C20	FC/PC60C	0.99	0.95	0.99
P(C,V)9*C20	FC/PC60C	0.98	0.97	0.98
P(C,V)9*D20	HC60	0.99	0.95	0.99
PV8*C20	HD60	0.99	0.94	0.99
P(C,V)9*D20	HD60	0.99	0.94	0.99
P(C,V)9*D20	MC61D	0.98	0.96	0.98

* = Single-phase outdoor units only.

HEATING PERFORMANCE DATA										
CONDENSING UNIT MODEL NO		E1RD018S06								
EVAPORATOR COIL MODEL NO		FC/MC/PC/UC18								
AIR TEMP. ENTERING OUTDOOR UNIT	AIR TEMP. ENTERING INDOOR COIL	ID CFM								
		450			600			750		
		MBTUH	KW	C.O.P.	MBTUH	KW	C.O.P.	MBTUH	KW	C.O.P.
60	60	20.9	1.5	4.1	21.7	0.7	8.8	22.5	1.4	4.6
	70	19.9	1.5	3.8	20.7	1.1	6.3	21.6	1.5	4.3
	80	18.8	1.6	3.5	19.7	1.6	3.7	20.6	1.5	4.0
47	60	17.4	1.3	3.8	18.4	1.3	4.1	19.3	1.3	4.4
	70	16.3	1.4	3.5	17.3	1.0	5.6	18.3	1.3	4.1
	80	15.2	1.4	3.1	16.3	0.7	7.0	17.3	1.4	3.7
40	60	15.5	1.3	3.6	16.4	1.2	3.9	17.3	1.2	4.2
	70	14.5	1.3	3.2	15.3	1.3	3.5	16.0	1.3	3.8
	80	13.4	1.3	2.9	14.1	1.3	3.1	14.8	1.3	3.3
30	60	13.2	1.2	3.2	13.8	1.2	3.4	14.3	1.2	3.6
	70	12.1	1.2	2.9	12.7	1.2	3.1	13.4	1.2	3.3
	80	10.9	1.3	2.5	11.7	1.2	2.8	12.5	1.2	3.0
17	60	9.6	1.1	2.5	10.0	1.1	2.6	10.4	1.1	2.8
	70	8.7	1.2	2.2	9.0	1.1	2.3	9.3	1.1	2.4
	80	7.8	1.2	1.9	8.0	1.2	2.0	8.2	1.2	2.1
10	60	8.4	1.2	2.1	8.9	1.1	2.3	9.5	1.1	2.5
	70	7.5	1.2	1.9	8.0	1.1	2.1	8.5	1.1	2.2
	80	6.5	1.2	1.6	7.0	1.2	1.8	7.5	1.1	1.9

NOTE: ALL CAPACITIES ARE NET (KBTUH) WITH INDOOR FAN HEAT ALREADY DEDUCTED AT 1250 BTUH/1000 CFM.

Multipliers for determining the performance with other indoor sections.

Air Handler	Coil	T.C.	S.C.	KW
MA08B	FC/MC18B	1.00	1.00	1.00
AHP18	–	1.00	0.99	0.98
F*FP024	–	0.99	0.99	0.98
MV12B	FC/MC18B	0.97	0.94	0.91
AV24	–	0.97	0.94	0.91
–	HC18	0.99	1.01	1.00

Variable Speed Furnace *	Coil	T.C.	S.C.	KW
PV8*A12	FC/MC/PC18A	0.97	0.93	0.91
PV9*A12	FC/MC/PC18A	0.98	0.95	0.93
P(C,V)9*B12	FC/MC/PC18B	0.97	0.94	0.91
PV8*A12	HC18	0.98	0.95	0.93
PV9*A12	HC18	0.97	0.93	0.91

HEATING PERFORMANCE DATA										
CONDENSING UNIT MODEL NO		E1RD024S06								
EVAPORATOR COIL MODEL NO		FC/MC/PC/UC24								
AIR TEMP. ENTERING OUTDOOR UNIT	AIR TEMP. ENTERING INDOOR COIL	ID CFM								
		600			800			1000		
		MBTUH	KW	C.O.P.	MBTUH	KW	C.O.P.	MBTUH	KW	C.O.P.
60	60	26.5	2.1	3.7	21.7	0.7	8.8	25.5	1.9	3.9
	70	25.6	2.1	3.5	20.7	1.1	6.3	25.4	2.0	3.7
	80	24.6	2.2	3.3	19.7	1.6	3.7	25.2	2.1	3.5
47	60	23.4	1.8	3.7	18.4	1.3	4.1	22.4	1.7	3.8
	70	22.3	1.9	3.5	17.3	1.0	5.6	22.3	1.8	3.6
	80	21.1	1.9	3.2	16.3	0.7	7.0	22.2	1.9	3.5
40	60	20.4	1.7	3.5	16.4	1.2	3.9	20.7	1.6	3.7
	70	19.3	1.8	3.2	15.3	1.3	3.5	20.4	1.7	3.5
	80	18.2	1.8	2.9	14.1	1.3	3.1	20.2	1.8	3.4
30	60	18.8	1.6	3.4	13.8	1.2	3.4	19.0	1.5	3.6
	70	16.9	1.6	3.0	12.7	1.2	3.1	17.8	1.6	3.3
	80	15.0	1.7	2.6	11.7	1.2	2.8	16.6	1.6	3.0
17	60	13.3	1.5	2.6	10.0	1.1	2.6	15.3	1.4	3.1
	70	11.4	1.5	2.2	9.0	1.1	2.3	13.0	1.5	2.6
	80	9.5	1.6	1.8	8.0	1.2	2.0	10.8	1.5	2.0
10	60	12.0	1.5	2.4	8.9	1.1	2.3	11.8	1.4	2.5
	70	9.6	1.5	1.9	8.0	1.1	2.1	10.0	1.5	2.0
	80	7.2	1.6	1.4	7.0	1.2	1.8	8.2	1.5	1.6

NOTE: ALL CAPACITIES ARE NET WITH INDOOR FAN HEAT ALREADY DEDUCTED AT 1250 BTUH/1000 CFM.

Multipliers for determining the performance with other indoor sections.

Air Handler	Coil	MBH	KW	COP
MA08B	FC/MC24B	1.00	1.00	1.00
MA08B	FC/MC30B	1.00	1.00	1.00
AHP24	–	1.00	1.00	1.00
F*FP030	–	1.00	1.00	1.00
MV12B	FC/MC24B	0.97	0.93	0.90
MV12B	FC/MC30B	0.97	0.93	0.90
AV24	–	0.97	0.93	0.90
–	FC/MC/PC/UC30	1.00	1.00	1.00
–	HC30	1.00	1.01	1.01
–	HD24	1.00	1.00	1.00

Variable Speed Furnace	Coil	MBH	KW	COP
PV8*A12	FC/MC/PC24A	0.97	0.96	0.93
PV9*A12	FC/MC/PC24A	0.97	0.96	0.93
P(C,V)9*B12	FC/MC/PC24B	0.97	0.96	0.93
PV8*A12	FC/MC/PC30A	0.97	0.96	0.93
PV9*A12	FC/MC/PC30A	0.97	0.96	0.93
P(C,V)9*B12	FC/MC/PC30B	0.97	0.96	0.93
PV8*A12	HC30	1.00	1.01	1.01
PV9*A12	HC30	1.00	1.01	1.01
PV8*A12	HD30	0.97	0.96	0.93
PV9*A12	HD30	0.97	0.96	0.93

HEATING PERFORMANCE DATA										
CONDENSING UNIT MODEL NO		E1RD030S06, E1RD030S(25,46)**								
EVAPORATOR COIL MODEL NO		FC/MC/PC35								
AIR TEMP. ENTERING OUTDOOR UNIT	AIR TEMP. ENTERING INDOOR COIL	ID CFM								
		800			1000			1200		
		MBTUH	KW	C.O.P.	MBTUH	KW	C.O.P.	MBTUH	KW	C.O.P.
60	60	33.3	2.4	4.1	32.4	1.2	8.1	31.6	2.9	3.1
	70	32.2	2.4	3.9	31.9	1.8	5.9	31.5	2.7	3.5
	80	31.1	2.5	3.6	31.3	2.5	3.7	31.4	2.4	3.8
47	60	29.2	2.1	4.1	28.8	2.1	4.1	28.4	2.0	4.1
	70	28.0	2.2	3.8	27.9	1.6	5.6	27.8	2.1	3.9
	80	26.7	2.2	3.5	27.0	1.1	7.1	27.3	2.2	3.7
40	60	25.9	2.0	3.8	26.1	1.9	3.9	26.2	1.9	4.0
	70	24.6	2.1	3.5	25.0	2.0	3.6	25.5	2.0	3.8
	80	23.2	2.1	3.2	24.0	2.1	3.4	24.8	2.1	3.5
30	60	22.9	1.9	3.6	22.8	1.8	3.7	22.7	1.8	3.7
	70	21.2	1.9	3.3	21.5	1.9	3.3	21.8	1.9	3.4
	80	19.6	2.0	2.9	20.3	2.0	3.0	20.9	1.9	3.2
17	60	17.1	1.7	2.9	17.2	1.7	2.9	17.4	1.7	3.0
	70	15.1	1.8	2.5	15.6	1.8	2.6	16.1	1.8	2.7
	80	13.2	1.9	2.0	14.0	1.9	2.2	14.7	1.9	2.3
10	60	14.9	1.7	2.5	14.9	1.7	2.6	14.9	1.7	2.6
	70	12.9	1.8	2.1	13.2	1.8	2.2	13.4	1.8	2.2
	80	10.9	1.8	1.8	11.4	1.8	1.8	11.9	1.8	1.9

NOTE: ALL CAPACITIES ARE NET (KBTUH) WITH INDOOR FAN HEAT ALREADY DEDUCTED AT 1250 BTUH/1000 CFM.
 ** For three-phase, decrease T.C. by 1.0 and S.C. by 0.7.

Multipliers for determining the performance with other indoor sections.

Air Handler	Coil	T.C.	S.C.	KW
MA12B	FC/MC35B	1.00	1.00	1.00
MA12B	FC/MC42B	1.00	1.00	1.00
AHP30	–	0.99	1.00	1.00
F*FP040	–	1.00	1.00	1.00
MV12B*	FC/MC35B	1.01	0.95	0.93
MV16C*	FC/MC35C	1.01	0.94	0.91
MV12B*	FC/MC42B	1.01	0.95	0.93
MV16C*	FC/MC42C	1.01	0.94	0.91
AV36*	–	1.01	0.95	0.93
–	FC/MC/PC/UC42	1.00	1.00	1.00
–	HC36	1.00	1.00	1.00
–	HD36	1.00	1.00	1.00

* = Single-phase outdoor units only.

Variable Speed Furnace *	Coil	T.C.	S.C.	KW
PV8*B16	FC/MC/PC35B	0.99	0.95	0.93
P(C,V)9*B12	FC/MC/PC35B	0.99	0.97	0.96
PV8*C16	FC/MC/PC35C	0.99	0.95	0.92
P(C,V)9*C16	FC/MC/PC35C	0.99	0.96	0.94
PV8*B16	FC/MC/PC42B	0.99	0.95	0.93
P(C,V)9*B12	FC/MC/PC42B	0.99	0.97	0.96
PV8*C16	FC/MC/PC42C	0.99	0.95	0.92
P(C,V)9*C16	FC/MC/PC42C	0.99	0.96	0.94
PV8*B16	HC36	0.99	0.95	0.90
P(C,V)9*B12	HC36	0.99	0.94	0.92
PV8*B16	HD36	0.99	0.94	0.92
P(C,V)9*B12	HD36	0.99	0.96	0.94

* = Single-phase outdoor units only.

HEATING PERFORMANCE DATA										
CONDENSING UNIT MODEL NO		E1RD036S06, E1RD036S(25,46)**								
EVAPORATOR COIL MODEL NO		FC/MC/PC/UC48								
AIR TEMP. ENTERING OUTDOOR UNIT	AIR TEMP. ENTERING INDOOR COIL	ID CFM								
		1000			1200			1400		
		MBTUH	KW	C.O.P.	MBTUH	KW	C.O.P.	MBTUH	KW	C.O.P.
60	60	41.6	2.4	5.0	42.2	2.3	5.3	42.7	2.2	5.6
	70	40.1	2.6	4.5	40.8	2.5	4.8	41.5	2.4	5.1
	80	38.6	2.8	4.1	39.5	2.7	4.3	40.4	2.6	4.6
47	60	35.3	2.3	4.6	35.5	2.2	4.8	35.7	2.1	4.9
	70	33.8	2.4	4.2	34.3	2.3	4.3	34.8	2.3	4.5
	80	32.4	2.5	3.7	33.1	2.5	3.9	33.8	2.4	4.1
40	60	31.4	2.2	4.2	31.4	2.1	4.4	31.5	2.0	4.5
	70	30.2	2.3	3.9	30.6	2.2	4.0	31.0	2.2	4.2
	80	29.1	2.4	3.5	29.8	2.4	3.7	30.4	2.3	3.8
30	60	27.4	2.0	3.9	27.3	2.0	4.0	27.3	2.0	4.1
	70	26.1	2.1	3.6	26.4	2.1	3.7	26.7	2.1	3.8
	80	24.9	2.2	3.3	25.5	2.2	3.4	26.1	2.2	3.5
17	60	21.4	1.9	3.4	21.5	1.8	3.4	21.7	1.8	3.5
	70	19.9	1.9	3.0	20.2	1.9	3.1	20.6	1.9	3.2
	80	18.4	2.0	2.7	18.9	2.0	2.8	19.4	2.0	2.9
10	60	17.9	1.8	3.0	17.8	1.7	3.0	17.7	1.7	3.0
	70	16.8	1.8	2.7	17.0	1.8	2.8	17.2	1.8	2.9
	80	15.7	1.8	2.5	16.1	1.8	2.6	16.6	1.8	2.7

NOTE: ALL CAPACITIES ARE NET (KBTUH) WITH INDOOR FAN HEAT ALREADY DEDUCTED AT 1250 BTUH/1000 CFM.
** For three-phase, decrease T.C. by 1.0 and S.C. by 0.7.

Multipliers for determining the performance with other indoor sections.

Air Handler	Coil	T.C.	S.C.	KW
MA12B	FC/MC35B	0.96	1.12	1.07
MA12B	FC/MC42B	0.96	1.12	1.07
MA14D	FC/MC48D	1.00	1.00	1.00
AHP36	–	0.93	1.12	1.07
F*FP040	–	0.95	1.12	1.07
F*FP042	–	0.95	1.12	1.07
MV16C*	FC/MC35C	0.89	1.09	0.97
MV16C*	FC/MC42C	0.89	1.09	0.97
MV16C*	FC/MC48C	0.98	0.94	0.92
MV20D*	FC/MC48D	0.98	0.94	0.92
AV36*	–	0.98	0.94	0.92
–	FC/MC/PC/UC42	0.96	1.12	1.07
–	HC42	0.99	1.00	0.99
–	HD36	1.00	1.00	1.00

* = Single-phase outdoor units only.

Variable Speed Furnace *	Coil	T.C.	S.C.	KW
PV8*B16	FC/MC/PC35B	0.92	1.10	0.97
P(C,V)9*B12	FC/MC/PC35B	0.92	1.08	0.96
PV8*C16	FC/MC/PC35C	0.92	1.10	0.97
PV8*C20	FC/MC/PC35C	0.92	1.08	0.96
P(C,V)9*C16	FC/MC/PC35C	0.93	1.13	1.02
P(C,V)9*C20	FC/MC/PC35C	0.93	1.10	0.97
PV8*B16	FC/MC/PC42B	0.92	1.10	0.97
P(C,V)9*B12	FC/MC/PC42B	0.92	1.08	0.96
PV8*C16	FC/MC/PC42C	0.92	1.10	0.97
PV8*C20	FC/MC/PC42C	0.92	1.08	0.96
P(C,V)9*C16	FC/MC/PC42C	0.93	1.13	1.02
P(C,V)9*C20	FC/MC/PC42C	0.93	1.10	0.97
PV8*C20	FC/MC/PC48C	0.98	0.95	0.93
P(C,V)9*C16	FC/MC/PC48C	0.98	0.96	0.94
P(C,V)9*C20	FC/MC/PC48C	0.98	0.95	0.93
P(C,V)9*D20	FC/MC/PC48D	0.98	0.95	0.93
PV8*C20	HC42	0.95	0.97	0.90
P(C,V)9*C16	HC42	0.96	0.97	0.90
P(C,V)9*C20	HC42	0.96	1.01	0.95
PV8*C20	HD36	0.96	0.95	0.90
P(C,V)9*C16	HD36	0.96	0.96	0.89
P(C,V)9*C20	HD36	0.96	0.96	0.89

* = Single-phase outdoor units only.

HEATING PERFORMANCE DATA										
CONDENSING UNIT MODEL NO		E1RD042S06, E1RD042S(25,46)**								
EVAPORATOR COIL MODEL NO		FC/MC/PC/UC48								
AIR TEMP. ENTERING OUTDOOR UNIT	AIR TEMP. ENTERING INDOOR COIL	ID CFM								
		1200			1400			1600		
		MBTUH	KW	C.O.P.	MBTUH	KW	C.O.P.	MBTUH	KW	C.O.P.
60	60	51.7	3.1	4.3	52.6	3.0	4.4	53.4	2.9	4.5
	70	49.6	3.2	3.9	50.4	3.2	4.0	51.3	3.1	4.1
	80	47.4	3.4	3.6	48.3	3.3	3.7	49.2	3.3	3.8
47	60	40.4	2.8	3.6	42.2	2.7	3.8	44.0	2.7	4.0
	70	39.7	3.0	3.4	42.0	2.9	3.6	42.5	2.8	3.6
	80	39.1	3.1	3.2	40.1	3.1	3.3	41.1	3.0	3.4
40	60	38.4	2.7	3.6	39.1	2.6	3.7	39.8	2.6	3.7
	70	35.7	2.8	3.3	36.9	2.7	3.3	38.1	2.7	3.4
	80	33.1	2.9	2.9	34.8	2.9	3.0	36.5	2.9	3.1
30	60	33.5	2.5	3.3	33.4	2.5	3.3	33.3	2.4	3.3
	70	31.0	2.6	3.0	31.7	2.6	3.0	32.3	2.5	3.0
	80	28.6	2.7	2.7	30.0	2.7	2.8	31.3	2.7	2.8
17	60	27.1	2.3	2.9	27.4	2.3	2.9	27.7	2.3	2.9
	70	25.2	2.4	2.6	25.0	2.4	2.6	26.4	2.4	2.6
	80	23.3	2.5	2.4	24.1	2.5	2.4	25.0	2.4	2.4
10	60	24.1	2.2	2.7	24.3	2.2	2.7	24.6	2.1	2.6
	70	22.6	2.3	2.5	22.9	2.2	2.4	23.2	2.2	2.4
	80	21.2	2.3	2.2	21.5	2.3	2.2	21.9	2.3	2.2

NOTE: ALL CAPACITIES ARE NET (KBTUH) WITH INDOOR FAN HEAT ALREADY DEDUCTED AT 1250 BTUH/1000 CFM.
** For three-phase, decrease T.C. by 1.0 and S.C. by 0.7.

Multipliers for determining the performance with other indoor sections.

Air Handler	Coil	T.C.	S.C.	KW
MA14D	FC/MC48D	1.00	1.00	1.00
MA16C	FC/MC48C	1.00	1.00	1.00
AHP/SHP48	—	1.00	1.02	1.02
MV16C*	FC/MC48C	0.99	0.97	0.96
MV20D*	FC/MC48D	0.99	0.97	0.96
AV/SV48*	—	0.99	0.97	0.96
—	HD48	0.99	1.00	0.99

* = Single-phase outdoor units only.

Variable Speed Furnace *	Coil	T.C.	S.C.	KW
PV8*C20	FC/MC/PC48C	0.99	0.98	0.97
P(C,V)9*C16	FC/MC/PC48C	0.99	0.98	0.97
P(C,V)9*C20	FC/MC/PC48C	0.98	0.96	0.94
P(C,V)9*D20	FC/MC/PC48D	0.98	0.95	0.93
PV8*C20	HD48	0.99	0.97	0.96
P(C,V)9*C16	HD48	0.99	0.98	0.97
P(C,V)9*C20	HD48	0.99	0.98	0.97

* = Single-phase outdoor units only.

HEATING PERFORMANCE DATA										
CONDENSING UNIT MODEL NO		E1RD048S06, E1RD048S(25,46)**								
EVAPORATOR COIL MODEL NO		FC/MC/PC/UC60								
AIR TEMP. ENTERING OUTDOOR UNIT	AIR TEMP. ENTERING INDOOR COIL	ID CFM								
		1400			1600			1800		
		MBTUH	KW	C.O.P.	MBTUH	KW	C.O.P.	MBTUH	KW	C.O.P.
60	60	55.2	3.3	4.9	54.7	3.2	5.0	54.2	3.1	5.1
	70	54.7	3.7	4.3	54.3	3.6	4.4	53.9	3.5	4.5
	80	54.1	4.1	3.9	53.9	3.9	4.1	53.6	3.8	4.1
47	60	46.9	3.2	4.3	46.6	3.1	4.5	45.2	2.9	4.6
	70	46.8	4.0	3.4	46.0	3.9	3.5	45.2	3.3	4.0
	80	45.7	3.8	3.2	45.4	4.0	3.3	45.2	3.7	3.6
40	60	42.4	3.0	4.1	42.0	2.9	4.2	41.7	2.8	4.4
	70	41.2	3.4	3.6	41.5	3.3	3.7	41.8	3.2	3.8
	80	40.0	3.7	3.2	41.0	3.6	3.3	41.9	3.5	3.5
30	60	36.6	2.9	3.7	36.3	2.8	3.8	36.0	2.8	3.8
	70	35.7	3.3	3.2	35.7	3.2	3.3	35.7	3.1	3.4
	80	34.8	3.7	2.8	35.1	3.6	2.9	35.3	3.5	3.0
17	60	30.2	2.8	3.1	30.1	2.7	3.3	30.1	2.7	3.3
	70	29.8	4.0	2.2	29.8	3.7	2.3	29.8	2.2	2.9
	80	29.7	3.8	2.0	29.5	3.8	2.1	29.4	2.0	2.5
10	60	27.3	2.8	2.9	27.0	2.7	2.9	26.6	2.6	3.0
	70	27.0	3.1	2.6	26.8	3.0	2.6	26.5	3.0	2.6
	80	26.7	3.4	2.3	26.6	3.4	2.3	26.5	3.3	2.4

NOTE: ALL CAPACITIES ARE NET (KBTUH) WITH INDOOR FAN HEAT ALREADY DEDUCTED AT 1250 BTUH/1000 CFM.
** For three-phase, decrease T.C. by 1.0 and S.C. by 0.7.

Multipliers for determining the performance with other indoor sections.

Air Handler	Coil	T.C.	S.C.	KW
MA16C	FC60C	1.00	1.00	1.00
MA20D	FC/MC60D	1.00	1.00	1.00
MA20D	MC61D	1.00	1.00	1.00
AHP/SHP48	–	1.00	1.02	1.02
AHP/SHP60	–	1.00	1.02	1.02
F*FV060*	–	0.99	0.97	0.96
MV20D*	FC/MC60D	0.99	0.98	0.97
MV20D*	MC61D	0.99	0.97	0.96
AV/SV48*	–	0.99	0.98	0.97
–	HC60	1.00	1.00	1.00
–	HD60	1.00	1.00	1.00
–	MC61	1.00	1.00	1.00

* = Single-phase outdoor units only.

Variable Speed Furnace *	Coil	T.C.	S.C.	KW
P(C,V)9*D20	FC/MC/PC60D	0.99	0.99	0.98
PV8*C16	FC/PC60C	0.99	1.00	0.99
PV8*C20	FC/PC60C	0.99	0.99	0.98
P(C,V)9*C16	FC/PC60C	0.98	1.00	0.98
P(C,V)9*C20	FC/PC60C	0.99	0.99	0.98
P(C,V)9*D20	HC60	0.99	0.99	0.98
PV8*C20	HD60	0.99	0.99	0.98
P(C,V)9*C20	HD60	0.99	0.99	0.98
P(C,V)9*D20	MC61D	0.99	0.98	0.97

* = Single-phase outdoor units only.

HEATING PERFORMANCE DATA										
CONDENSING UNIT MODEL NO		E1RD060S06, E1RD060S(25,46)**								
EVAPORATOR COIL MODEL NO		FC/MC/PC/UC60								
AIR TEMP. ENTERING OUTDOOR UNIT	AIR TEMP. ENTERING INDOOR COIL	ID CFM								
		1600			1800			2000		
		MBTUH	KW	C.O.P.	MBTUH	KW	C.O.P.	MBTUH	KW	C.O.P.
60	60	72.1	4.4	4.3	72.8	4.1	4.5	73.6	3.9	4.6
	70	71.0	4.9	3.8	71.8	4.7	3.9	72.5	4.4	4.1
	80	69.9	5.5	3.4	70.7	5.3	3.5	71.4	5.0	3.7
47	60	60.0	4.1	3.8	60.7	3.9	3.9	61.4	3.7	4.1
	70	57.2	4.6	3.2	58.0	4.2	3.5	60.3	4.2	3.6
	80	58.5	5.2	3.0	57.8	5.0	3.0	59.1	4.7	3.2
40	60	48.4	3.9	3.2	50.7	3.8	3.3	53.1	3.7	3.5
	70	48.8	4.4	2.9	51.0	4.3	3.0	53.2	4.2	3.2
	80	49.3	5.0	2.6	51.3	4.8	2.8	53.3	4.6	2.9
30	60	44.4	3.7	3.1	42.0	3.5	2.9	39.7	3.4	2.8
	70	43.9	4.2	2.7	43.3	4.1	2.7	42.8	3.9	2.7
	80	43.4	4.8	2.4	44.6	4.6	2.5	45.8	4.5	2.6
17	60	37.4	3.5	2.7	36.2	3.5	2.6	35.0	3.4	2.5
	70	34.9	3.9	2.3	35.0	3.8	2.3	36.2	3.8	2.3
	80	32.4	4.3	1.9	34.9	4.3	2.1	37.4	4.2	2.2
10	60	29.0	3.6	2.0	30.1	3.4	2.2	31.2	3.3	2.3
	70	30.6	4.0	2.0	31.1	3.9	2.0	31.7	3.9	2.0
	80	32.1	4.4	1.9	32.2	4.4	1.9	32.2	4.4	1.8

NOTE: ALL CAPACITIES ARE NET (KBTUH) WITH INDOOR FAN HEAT ALREADY DEDUCTED AT 1250 BTUH/1000 CFM.
** For three-phase, decrease T.C. by 1.0 and S.C. by 0.7.

Multipliers for determining the performance with other indoor sections.

Air Handler	Coil	T.C.	S.C.	KW
MA20D	FC/MC60D	1.00	1.00	1.00
MA20D	MC61D	1.00	1.00	1.00
AHP/SHP60	–	1.00	1.02	1.02
F*FV060*	–	0.99	0.99	0.98
MV20D*	FC/MC60D	0.99	0.99	0.98
MV20D*	MC61D	0.99	0.98	0.97
AV/SV60*	–	0.99	0.99	0.98
–	HC60	0.99	1.01	1.00
–	HD60	1.00	1.00	1.00
–	MC61	1.00	1.00	1.00

* = Single-phase outdoor units only.

Variable Speed Furnace *	Coil	T.C.	S.C.	KW
P(C,V)9*D20	FC/MC/PC60D	0.97	0.99	0.95
PV8*C20	FC/PC60C	0.99	0.99	0.99
P(C,V)9*C20	FC/PC60C	0.98	1.00	1.00
P(C,V)9*D20	HC60	0.97	0.99	0.96
PV8*C20	HD60	0.97	0.99	0.99
P(C,V)9*D20	HD60	0.97	0.99	0.96
P(C,V)9*D20	MC61D	0.97	0.99	0.95

* = Single-phase outdoor units only.

NOTES

Subject to change without notice. Printed in U.S.A.
Copyright © by York International Corp. 2007. All rights reserved.

246818-YTG-G-0607
Supersedes: 246818-YTG-F-0107

**Unitary
Product
Group**

**5005
York
Drive**

**Norman
OK
73069**