



YORK®

Heating and Air Conditioning

TECHNICAL GUIDE

AFFINITY

MODELS: PC9*UP

GAS-FIRED CONDENSING / HIGH EFFICIENCY UPFLOW MODULATING FURNACES WITH ECM MOTORS

NATURAL GAS

60 - 120 MBH INPUT



Due to continuous product improvement, specifications are subject to change without notice.

Visit us on the web at www.york.com for the most up-to-date technical information.

Additional rating information can be found at www.gamanet.org.

DESCRIPTION

These Category IV, highly efficient, compact, condensing type furnaces are designed for residential and commercial installations in a basement, closet, alcove, recreation room or garage where the ambient temperature is above 32°F, or higher. They may be either side wall or thru-roof vented using approved plastic type combustion air and vent piping. All units are factory assembled, wired and tested to assure dependable and economical installation and operation.

WARRANTY

Lifetime limited warranty on both heat exchangers to the original purchaser; a 20-year limited warranty from original installation date to subsequent purchaser.

10-year warranty on the heat exchanger in commercial applications.

5-year limited parts warranty.

FEATURES

- Modulating heating operation includes:
 - Modulating gas valve
 - Modulating inducer operation
- Provides increased comfort level & very quiet unit operation
- Compact, easy to install, ideal height 40" cabinet
- Blower-off delay for cooling SEER improvement.
- Easy to connect power/control wiring.
- Built-in, high level self diagnostics with fault code display.
- Low unit amp requirement for easy replacement application.
- Integrated control module for reliable, economical operation.
- May be installed as either two-pipe (direct vent) or single pipe vent (using indoor combustion air)
- Top intake & vent connection allows installation in narrow locations.
- Electronic Hot Surface Ignition saves fuel cost with increased dependability and reliability.
- Induced combustion system with inshot main burners for quiet, efficient operation.
- No special vent termination kit required.
- 100% shut off main gas valve for extra safety.
- ECM high efficiency direct drive motor with large, quiet blower.
- 24V, 40 VA control transformer and blower relay supplied for add-on cooling.
- Hi-tech tubular aluminized steel primary heat exchanger.
- Secondary (condensing) heat exchanger of 29-4C high-grade stainless steel.
- Solid removable bottom panel allows easy application.
- Easy access from front of unit for cleaning, maintenance or service.
- Protection from intake, exhaust or condensate blockage.
- Insulated blower compartment for quiet operation.

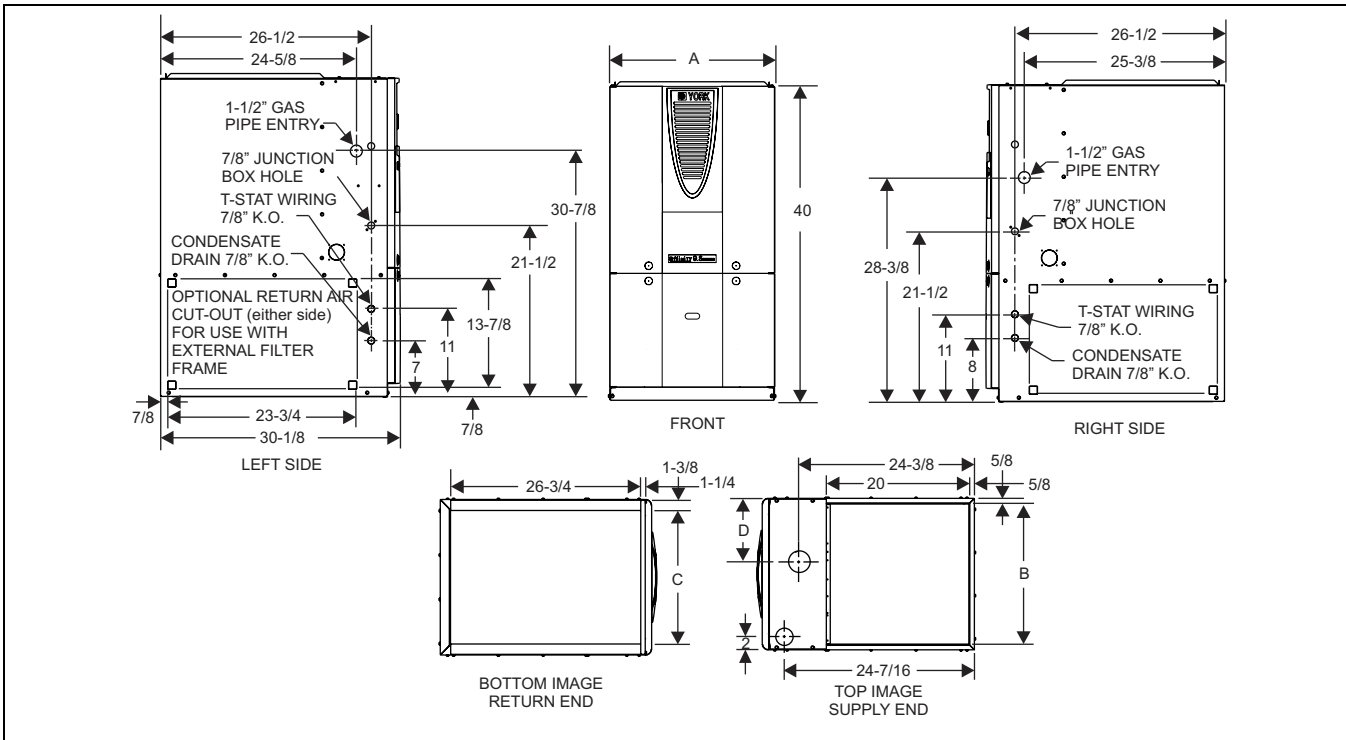

DIMENSIONS

Models	Nominal CFM	Cabinet Size	Cabinet Dimension			
			A (in.)	B (in.)	C (in.)	D (in.)
PC9B12N060UP11	1200	B	17-1/2	16-1/4	15-1/8	8-1/2
PC9B12N080UP11	1200	B	17-1/2	16-1/4	15-1/8	8-1/2
PC9C16N080UP11	1600	C	21	19-3/4	18-1/2	8-7/8
PC9C16N100UP11	1600	C	21	19-3/4	18-1/2	8-7/8
PC9C20N100UP11	2000	C	21	19-3/4	18-1/2	8-7/8
PC9D20N120UP11	2000	D	24-1/2	23-1/4	21-7/8	10-5/8

COMBUSTION AIR SUPPLY AND VENT PIPING

MAXIMUM ELBOWS AND VENT LENGTHS										
Models Input BTUH	Pipe Size Inches	Maximum Number of Elbows*								Minimum Length
		1	2	3	4	5	6	7	8	
60,000	2	60	55	50	45	40	30	20	10	5
60,000	3	85	80	75	70	65	60	50	40	5
80,000	2	60	55	50	45	40	30	20	10	5
80,000	3	85	80	75	70	65	60	50	40	5
100,000	2	25	20	15	N/A	N/A	N/A	N/A	N/A	5
100,000	3	85	80	75	70	65	60	50	40	5
120,000	3	75	70	65	60	55	45	35	25	5

Three elbows (two in vent pipe and one in the air intake pipe) are already accounted for and need not be included in the elbow count from the Table above.

ELECTRICAL AND PERFORMANCE DATA

Models	Input Max/Min	Output Max/Min	Blower Size	Blower		Max. Over-current Protect	Air Temp. Rise Maximum Input	Air Temp. Rise Minimum Input
	MBH	MBH		HP	Amps		°F	°F
PC9B12N060UP11	60/21	57/20	11 x 8	1/2	7.7	20	40 - 70	20 - 50
PC9B12N080UP11	80/28	76/26	11 x 8	1/2	7.7	20	40 - 70	20 - 50
PC9C16N080UP11	80/28	76/26	11 x 10	3/4	9.6	20	40 - 70	20 - 50
PC9C16N100UP11	100/35	95/33	11 x 10	3/4	9.6	20	40 - 70	20 - 50
PC9C20N100UP11	100/35	95/33	11 x 11	1	12.8	20	40 - 70	20 - 50
PC9D20N120UP11	120/42	115/39	11 x 11	1	12.8	20	40 - 70	20 - 50

Models	Max. Outlet Air Temp.	Nominal Airflow	Cabinet Width	Total Unit	AFUE	Min. Wire Size (awg) @ 75 ft. One Way	Approximate Operating Weight
	°F	CFM		Amps	%		
PC9B12N060UP11	170	1200	17-1/2	9	95.0	14	135
PC9B12N080UP11	170	1200	17-1/2	9	95.0	14	142
PC9C16N080UP11	170	1600	21	12	95.0	14	157
PC9C16N100UP11	170	1600	21	12	95.0	14	162
PC9C20N100UP11	170	2000	21	14	95.0	12	164
PC9D20N120UP11	170	2000	24-1/2	14	95.0	12	180

Annual Fuel Utilization Efficiency (AFUE) numbers are determined in accordance with DOE Test procedures.

Wire size and over current protection must comply with the National Electrical Code (NFPA-70-latest edition) and all local codes.

The furnace shall be installed so that the electrical components are protected from water.

NOTES:

1. Wire size based on copper conductors, 60°C, 3% voltage drop.
2. Continuous return air temperature must not be below 55°F.
3. Air flows above 1800 CFM require either return from two sides or one side plus bottom.

For additional connection diagrams for all UPG equipment refer to "Low Voltage System Wiring" document available online at www.upgnet.com in the Product Catalog Section.

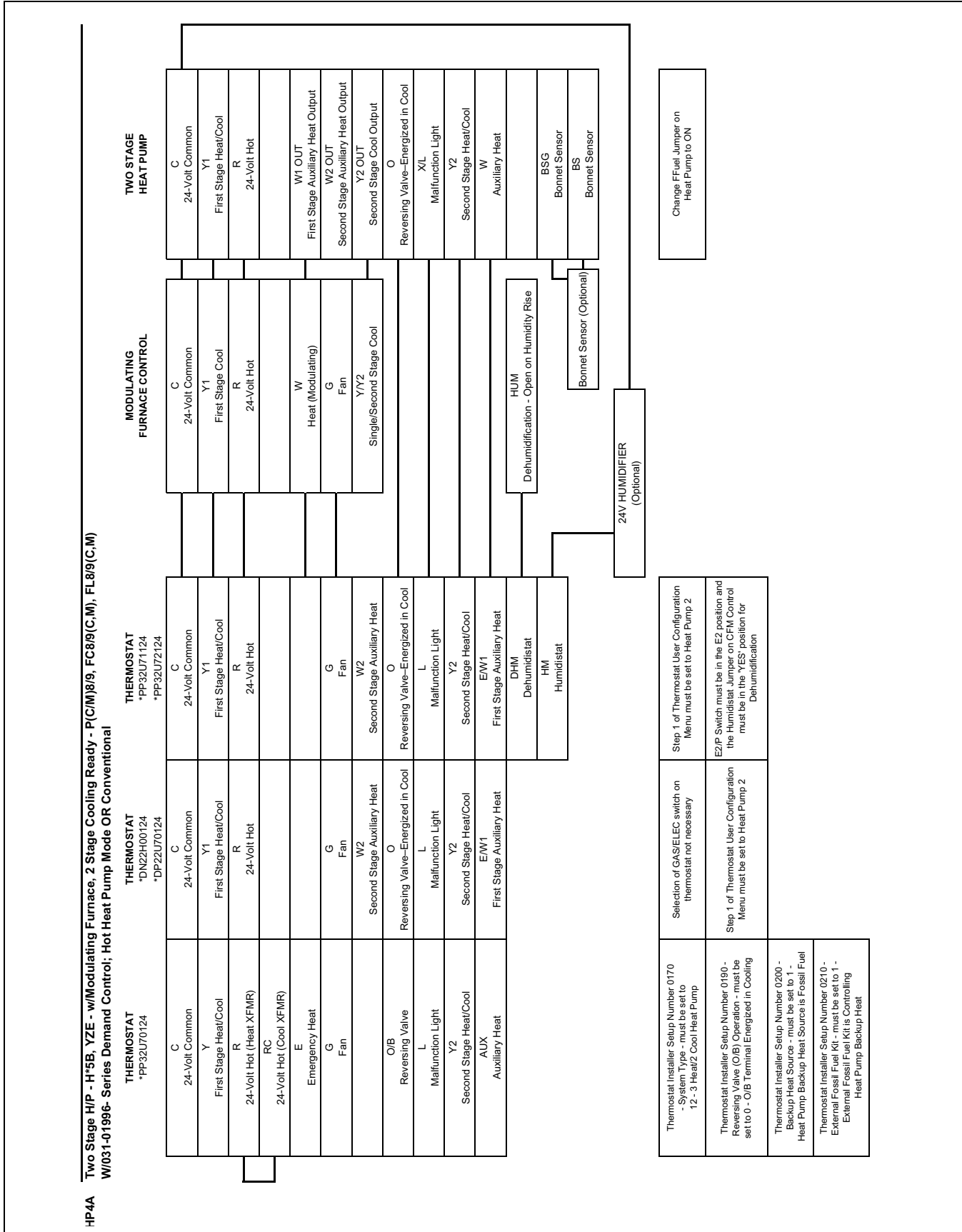

THERMOSTAT CHART - TWO STAGE HP

AC20 2 Stage Scroll A/C w/Modulating Furnace, 2 Stage Cooling Ready - P(C/M)8/9, FC8/9(C,M), FL8/9(C,M)

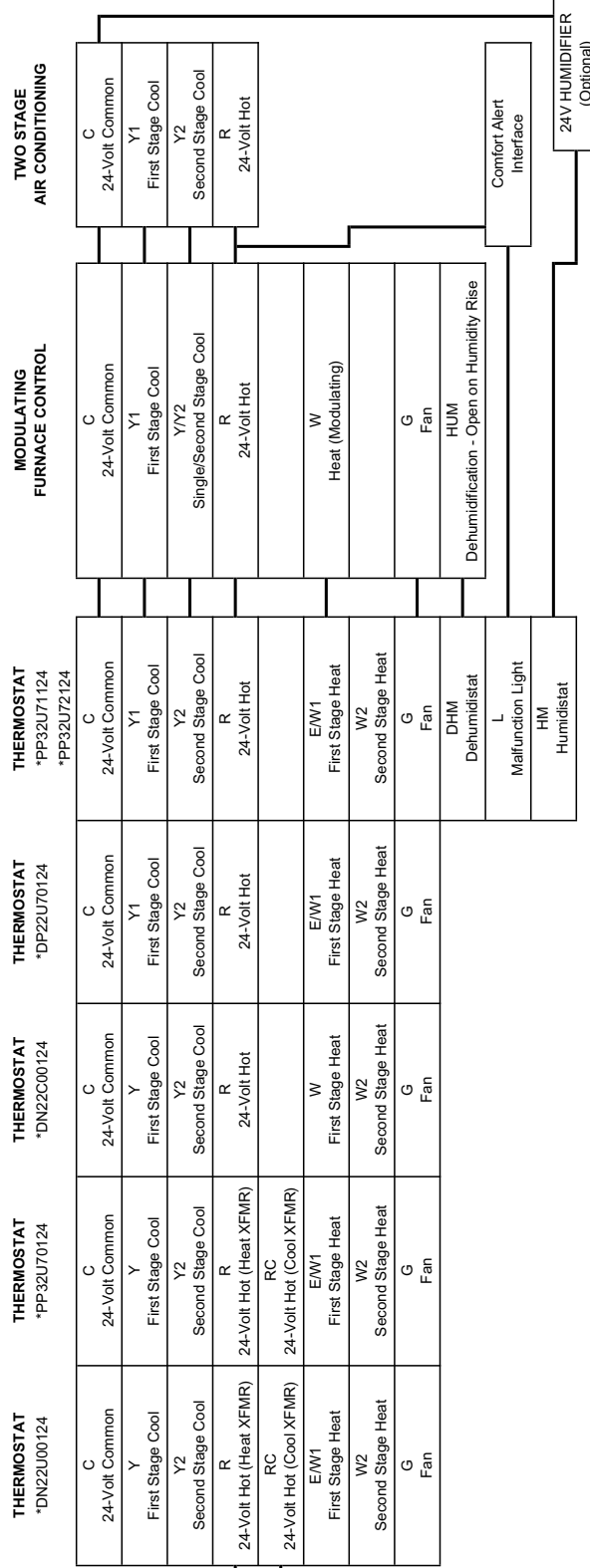

Connection of the "C" Terminal, 24-Volt Common, is optional when used with batteries	Connection of the "C" Terminal, 24-Volt Common, is optional when used with batteries	Connection of the "C" Terminal, 24-Volt Common, is optional when used with batteries	Connection of the "C" Terminal, 24-Volt Common, is optional when used with batteries	Step 1 of Thermostat User Configuration Menu must be set to MLT1 STG
Thermostat Installer Setup Number 1 - System Type - must be set to 8 - 1 Heat/2 Cool Conventional	Thermostat Installer Setup Number 1 - System Type - must be set to 8 - 2 Heat/2 Cool Multistage Conventional			Step 16 of Thermostat User Configuration Menu must be set to ON to use Comfort Alert Features
Thermostat Installer Setup Number 15 - Compressor Protection - must be set to 5				E2/P Switch must be in the E2 position and the Humidistat Jumper on CFM Control must be in the 'YES' position for Dehumidification

THERMOSTAT CHART - TWO STAGE AC

AIR FLOW DATA

HIGH / LOW SPEED COOLING AND HEAT PUMP CFM									
PC9B12N060UP11				PC9B12N080UP11				JUMPER SETTINGS	
CFM		m ³ /min		CFM		m ³ /min		COOL Tap	ADJ Tap
High	Low	High	Low	High	Low	High	Low		
1330	900	37.7	25.5	1310	890	37.1	25.2	A	B
1130	800	32.0	22.7	1100	740	31.2	21.0	B	B
1220	850	34.6	24.1	1220	830	34.6	23.5	A	A
1040	730	29.4	20.7	1000	670	28.3	19.0	B	A
1120	770	31.7	21.8	1090	720	30.9	20.4	A	C
920	650	26.1	18.4	900	610	25.5	17.3	C	B
950	660	26.9	18.7	880	610	24.1	17.3	B	C
740	540	21.0	15.3	680	510	19.3	14.4	D	B
860	610	24.4	17.3	810	580	22.9	16.4	C	A
690	540	19.5	15.3	630	500	17.8	14.2	D	A
790	570	22.4	16.1	730	530	20.7	15.0	C	C
630	530	17.8	15.0	590	500	16.7	14.2	D	C
PC9C16N080UP11 PC9C16N100UP11				PC9C20N100UP11				JUMPER SETTINGS	
CFM		m ³ /min		CFM		m ³ /min		COOL Tap	ADJ Tap
High	Low	High	Low	High	Low	High	Low		
1660	1110	47.0	31.4	2210	1480	62.6	41.9	A	B
1550	1050	43.9	29.7	1780	1180	50.4	33.4	B	B
1610	1070	45.6	30.3	2040	1350	57.8	38.2	A	A
1440	960	40.8	27.2	1620	1050	45.9	29.7	B	A
1470	990	41.6	28.0	1840	1250	52.1	35.4	A	C
1370	920	38.8	26.1	1560	1010	44.2	28.6	C	B
1290	850	36.5	24.1	1470	940	41.6	26.6	B	C
1130	790	32.0	22.4	1370	890	38.8	25.2	D	B
1230	850	34.8	24.1	1460	930	41.3	26.3	C	A
1050	720	29.7	20.4	1250	790	35.4	22.4	D	A
1110	760	31.4	21.5	1310	810	37.1	22.9	C	C
950	660	26.9	18.7	1090	690	30.9	19.5	D	C
PC9D20N120UP11								JUMPER SETTINGS	
CFM		m ³ /min						COOL Tap	ADJ Tap
High	Low	High	Low						
2280	1510	64.6	42.8					A	B
1860	1190	52.7	33.7					B	B
2090	1370	59.2	38.8					A	A
1630	1060	46.2	30.0					B	A
1880	1250	53.2	35.4					A	C
1620	1030	45.9	29.2					C	B
1500	960	42.5	27.2					B	C
1410	880	39.9	24.9					D	B
1490	920	42.2	26.1					C	A
1290	790	36.5	22.4					D	A
1360	840	38.5	23.8					C	C
1140	690	32.3	19.5					D	C

All CFM's are shown at 0.5" w.c. external static pressure. These units have variable speed motors that automatically adjust to provide constant CFM from 0.0" to 0.6" w.c. static pressure. From 0.6" to 1.0" static pressure, CFM is reduced by 2% per 0.1" increase in static. Operation on duct systems with greater than 1.0" w.c. external static pressure is not recommended.

NOTE: At some settings, LOW COOL airflow may be lower than what is required to operate an airflow switch on certain models of electronic air cleaners. Consult the instructions for the electronic air cleaner for further details.

NOTES:

1. Airflow expressed in standard cubic feet per minute (CFM) and in cubic meters per minute (m³/min).
2. Return air is through side opposite motor (left side).
3. In order to stay within the velocity rating the filters, airflows above 1800 CFM (50.97 m³/min) require either return from two sides or one side plus bottom.

FILTER PERFORMANCE

The airflow capacity data published in the “Blower Performance” table listed above represents blower performance WITHOUT filters. To determine the approximate blower performance of the system, apply the filter drop value for the filter being used or select an appropriate value from the “Filter Performance” table shown.

NOTE: The filter pressure drop values in the “Filter Performance” table shown are typical values for the type of filter listed and should only be used as a guideline. Actual pressure drop ratings for each filter type vary between filter manufacturer.

FILTER PERFORMANCE - PRESSURE DROP INCHES W.C. AND (KPA)

Airflow Range	Minimum Opening Size		Filter Type					
			Disposable		Washable Fiber		Pleated	
	1 Opening Sq. in.	2 Openings Sq. in.	1 Opening In w.c.	2 Opening In w.c.	1 Opening In w.c.	2 Opening In w.c.	1 Opening In w.c.	2 Opening In w.c.
0 - 750	230		0.01		0.01		0.15	
751 - 1000	330		0.04		0.03		0.20	
1001 - 1250	330		0.08		0.07		0.20	
1251 - 1500	330		0.08		0.07		0.25	
1501 - 1750	380	658	0.14	0.08	0.13	0.06	0.30	0.17
1751 - 2000	380	658	0.17	0.09	0.15	0.07	0.30	0.17
2001 & Above	463	658	0.17	0.09	0.15	0.07	0.30	0.17

APPLYING FILTER PRESSURE DROP TO DETERMINE SYSTEM AIRFLOW

To determine the approximate airflow of the unit with a filter in place, follow the steps below:

1. Select the filter type.
2. Select the number of return air openings or calculate the return opening size in square inches to determine the proper filter pressure drop.
3. Determine the External System Static Pressure (ESP) without the filter.
4. Select a filter pressure drop from the table based upon the number of return air openings or return air opening size and add to the ESP from Step 3 to determine the total system static.
5. If total system static matches a ESP value in the airflow table (i.e. 0.20, 0.60, etc,) the system airflow corresponds to the intersection of the ESP column and Model/ Blower Speed row.

UNIT CLEARANCES TO COMBUSTIBLES

Application	Top	Front	Rear	Left Side	Right Side	Flue	Floor/ Bottom	Closet Alcove	Attic
	In.	In.	In.	In.	In.	In.			
Upflow	1	3	0	0	0	0	Combustible	Yes	Yes

ACCESSORIES

PROPANE (LP) CONVERSION KIT -

1NP0680 - All units

This accessory conversion kit must be used to convert natural gas (N) units for propane (LP) operation. Conversions must be made by qualified distributor or dealer personnel.

CONCENTRIC VENT TERMINATION -

1CT0302 (2")

1CT0303 (3")

For use through rooftop, sidewall. Allows combustion air to enter and exhaust to exit through single common hole.

CONDENSATE NEUTRALIZER KIT - 1NK0301

Neutralizer cartridge has a 1/2" plastic tube fittings for installation in the drain line. Calcium carbonate refill media is also available from the Source 1 Parts (p/n 026-30228-000).

SIDEWALL VENT TERMINATION - 1HT0901

For use on sidewall, two-pipe installations only. Provides a more attractive termination for locations where the terminal is visible on the side of the home.

SIDE RETURN FILTER -

1SR0402 - All Models

1SR0200 - All Models

BOTTOM RETURN FILTER -

1BR0114 or 1BR0214 - For 14-1/2" cabinets

1BR0117 or 1BR0217 - For 17-1/2" cabinets

1BR0121 or 1BR0221 - For 21" cabinets

1BR0124 or 1BR0224 - For 24-1/2" cabinets

ROOM THERMOSTATS - A wide selection of compatible thermostats are available to provide optimum performance and features for any installation.

1 Heat Stage only, manual, mechanical thermostat. Add sub-base for 1H/1C.

1H/1C, manual change-over electronic non-programmable thermostat.

1H/1C, auto/manual changeover, electronic programmable, deluxe 7-day, thermostat.

1H/1C, auto/manual changeover, electronic programmable.

* For the most current accessory information, refer to the price book or consult factory.