



Heating and Air Conditioning

TECHNICAL GUIDE

SPLIT-SYSTEM AIR CONDITIONERS

14 SEER – R-22

MODELS:
H*RE018 THRU 060
(1.5 THRU 5 NOMINAL TONS)

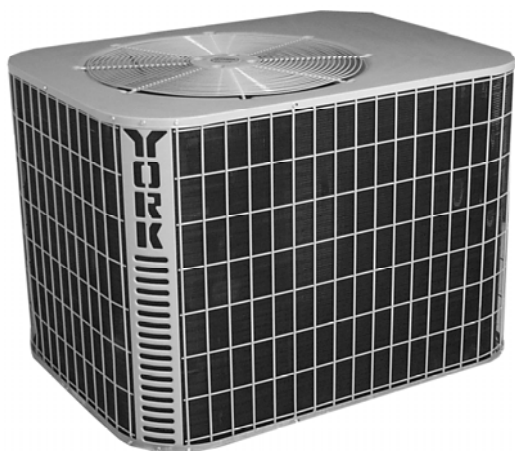

Due to continuous product improvement, specifications are subject to change without notice.

Visit us on the web at www.york.com

Additional rating information can be found at www.ari.org/ari-directory.

DESCRIPTION

The 14 SEER Series condensing unit is the outdoor part of a versatile system of air conditioning. It is designed to be custom-matched with one of UPG's complete line of evaporator sections, with each serving a specific function. Matching Air Handlers are available for upflow, downflow, or horizontal applications to provide a complete system. Electric Heaters are available, if required. Add-On coils are available for use with upflow, downflow, or horizontal furnaces and air handlers.

WARRANTY

5-year limited parts warranty.

10-year limited compressor warranty.

FEATURES

- **QUALITY CONDENSER COILS** - The coil is constructed of copper tube and aluminum fins.
- **PROTECTED COMPRESSOR** - The compressor is internally protected against high pressure and temperature. This is accomplished by the simultaneous operation of high pressure relief valve and a temperature sensor which protects the compressor if undesirable operating conditions occur. A liquid line filter-drier further protects the compressor.
- **DURABLE FINISH** - The cabinet is made of pre-painted steel. The pre-treated galvanized steel provides a better paint to steel bond, which resists corrosion and rust creep. Special primer formulas and desert sand matted-textured finish insure less fading when exposed to sunlight.
- **LOWER INSTALLED COST** - Installation time and costs are reduced by easy power and control wiring connections. Discharge line heat exchanger knockouts are provided, if required. Available in sweat connect models only. The unit contains enough refrigerant for matching indoor coils and 15 feet of interconnecting piping. The small base dimension means less space is required on the ground or roof.
- **TOP DISCHARGE** - The warm air from the top mounted fan is blown up away from the structure and any landscaping. This allows compact location on multi-unit applications.
- **LOW OPERATING SOUND LEVEL** - The upward air flow carries the normal operating noise away from the living area. The rigid top panel effectively isolates any motor sound. Isolator mounted compressor and the rippled fins of the condenser coil muffle the normal fan motor and compressor operating sounds.
- **LOW MAINTENANCE** - Long life permanently lubricated motor-bearings need no annual servicing.
- **EASY SERVICE ACCESS** - Fully exposed refrigerant connections, a single panel covering the electrical controls, and the molex plug in the control box connecting the condenser fan make for easy servicing of the unit.
- **SECURED SERVICE VALVES** - Secured re-usable service valves are provided on both the liquid and vapor sweat connections for ease of evacuating and charging.
- **U.L. and C.U.L. listed** - approved for outdoor application. Certified in accordance with the Unitary Small Equipment certification program, which is based on ARI Standard 210/240.

Physical and Electrical Data

MODEL	H1RE018S06	H4RE024S06	H3RE030S06	H1RE036S06	H2RE042S06	H2RE048S06	H3RE060S06
Unit Supply Voltage	208-230V, 1 ϕ , 60Hz						
Normal Voltage Range ¹	187 to 252						
Minimum Circuit Ampacity	8.5	10.5	16.9	18.1	17.8	20.6	33.5
Max. Overcurrent Device Amps ²	15	15	25	25	30	35	50
Min. Overcurrent Device Amps ³	15	15	20	20	20	25	35
Compressor Type	Recip	Recip	Recip	Scroll	Scroll	Scroll	Scroll
Compressor Amps	Rated Load	6.4	8.0	12.8	13.5	13.2	25.6
	Locked Rotor	36	40.5	68	73	95	150
Crankcase Heater	No	No	No	No	No	No	No
Fan Motor Amps	Rated Load	0.5	0.5	0.8	1.5	1.5	1.5
Fan Diameter Inches	22	22	22	22	24	24	24
Fan Motor	Rated HP	1/15	1/15	1/8	1/4	1/4	1/4
	Nominal RPM	830	830	1075	850	850	850
	Nominal CFM	2,100	2,000	2,800	3,300	3,300	3,600
Coil	Face Area Sq Ft	15.71	15.71	23.58	23.58	22.50	27.00
	Rows Deep	1	1	1	1	2	2
	Fin /Inch	22	22	22	18	18	18
Liquid Line Set OD (Field Installed)	3/8	3/8	3/8	3/8	3/8	3/8	3/8
Vapor Line Set OD (Field Installed)	3/4	3/4	7/8	7/8	1 1/8	1 1/8	1 1/8
Unit Charge (Lbs - Oz) ⁴	5 - 9	6 - 0	8 - 2	9 - 6	14 - 0	14 - 3	16 - 5
Charge Per Foot, oz.	0.68	0.68	0.70	0.68	0.76	0.76	0.76
Operating Weight Lbs	170	181	193	219	240	264	279

1. Rated in accordance with ARI Standard 110, utilization range "A".
2. Dual element fuses or HACR circuit breaker. Maximum allowable overcurrent protection.
3. Dual element fuses or HACR circuit breaker. Minimum recommended overcurrent protection.
4. The Unit Charge is correct for the outdoor unit, matched indoor coil and 15 feet of refrigerant tubing. For tubing lengths other than 15 feet, add or subtract the amount of refrigerant, using the difference in length multiplied by the per foot value.

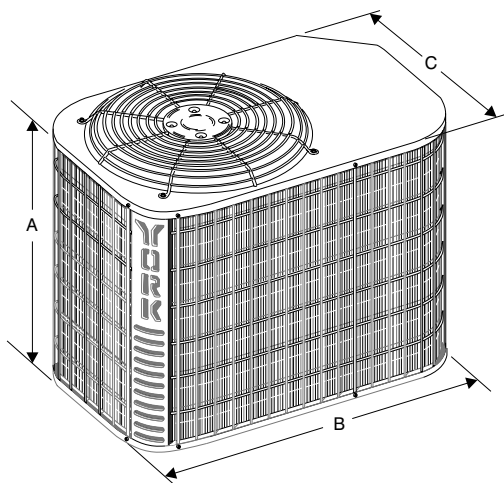

All dimensions are in inches. They are subject to change without notice. Certified dimensions will be provided upon request.

Unit Model	Dimensions (Inches)			Refrigerant Connection Service Valve Size	
	A ¹	B	C	Liquid	Vapor
018	27	37	27	3/8	3/4
024	27	37	27		
030	39	37	27		7/8
036	39	37	27		
042	32	43	32		
048	38	43	32		1-1/8
060	38	43	32		

1. Included Fan Guard.

* Adapter fitting required for 1-1/8" line set.

Additional R-22 Charge / Orifice Size for Various Matched Systems - 1 Phase							
Outdoor Unit	H1RE018S06	H4RE024S06	H3RE030S06	H1RE036S06	H2RE042S06	H2RE048S06	H3RE060S06
Required TXV ¹	1TVM2A1	1TVM2A1	1TVM2A1	1TVM702	1TVM703	1TVM703	1TVM2C1
Factory R-22 Charge, lbs-oz	5 - 9	6 - 0	8 - 2	9 - 6	14 - 0	14 - 3	16 - 5
Indoor Coil ^{2,3}	TXV ⁴ + Charge Adder, Oz						
FC/MC/PC24A2A	0	-	-	-	-	-	-
FC/MC/PC24B2A	0	-	-	-	-	-	-
FC/MC/PC30A2A	0	-	-	-	-	-	-
FC/MC/PC30B2A	0	-	-	-	-	-	-
FC/MC/PC35B2A	-	0	-	-	-	-	-
FC/MC/PC35C2A	-	0	-	-	-	-	-
FC/MC/PC36A2A	-	-	0	-	-	-	-
FC/MC/PC36B2A	-	-	0	-	-	-	-
FC/MC/PC36C2A	-	-	0	-	-	-	-
FC/PC60C2C	-	-	-	-	-	-	0*
FC/MC/PC60D2C	-	-	-	-	-	-	0*
MC61D2C	-	-	-	-	-	-	0
HC30A2A	0	-	-	-	-	-	-
HC36B2A	-	0	0	-	-	-	-
HC60D2C	-	-	-	-	-	-	0*
HD24A2A	-	-	-	-	-	-	-
HD36B2A	-	0	0	-	-	-	-
HD60D2C	-	-	-	-	-	-	0*
UC24A2A	0	-	-	-	-	-	-
UC24B2A	0	-	-	-	-	-	-
UC30A2A	0	-	-	-	-	-	-
UC30B2A	0	-	-	-	-	-	-
UC36A2A	-	-	0	-	-	-	-
UC36B2A	-	-	0	-	-	-	-
UC36C2A	-	-	0	-	-	-	-
UC60C2C	-	-	-	-	-	-	0*
UC60D2C	-	-	-	-	-	-	0*
AHP24B2A	0	-	-	-	-	-	-
AHP30B2A	-	0	0	-	-	-	-
AHP/SHP60D2C	-	-	-	-	-	-	0
AV24B2A	0	-	-	-	-	-	-
AV36C2A	-	0	0	-	-	-	-
AV/SV60D2C	-	-	-	-	-	-	0
FC/MC/PC24A3X	2A + 0	-	-	-	-	-	-
FC/MC/PC24B3X	2A + 0	-	-	-	-	-	-
FC/MC/PC30A3X	2A + 0	-	-	-	-	-	-
FC/MC/PC30B3X	2A + 0	-	-	-	-	-	-
FC/MC/PC35B3X	-	2A + 0	-	-	-	-	-
FC/MC/PC35C3X	-	2A + 0	-	-	-	-	-
FC/MC/PC36A3X	-	-	2A + 0	-	-	-	-
FC/MC/PC36B3X	-	-	2A + 0	-	-	-	-
FC/MC/PC36C3X	-	-	2A + 0	-	-	-	-
FC/MC/PC42B3X	-	-	-	702 + 0	-	-	-
FC/MC/PC42X3X	-	-	-	702 + 0	-	-	-
FC/MC/PC48C3X	-	-	-	702 + 12	703 + 9*	-	-
FC/MC/PC48D3X	-	-	-	702 + 12	703 + 9*	-	-
FC/PC60C3X	-	-	-	-	703 + 13	703 + 6*	2C + 0*
FC/MC/PC60D3X	-	-	-	-	703 + 13	703 + 6*	2C + 0*
MC61D3X	-	-	-	-	-	703 + 13	2C + 0

For Notes See Page 4.

Additional R-22 Charge / Orifice Size for Various Matched Systems - 1 Phase (Continued)							
Outdoor Unit	H1RE018S06	H4RE024S06	H3RE030S06	H1RE036S06	H2RE042S06	H2RE048S06	H3RE060S06
Required TXV ¹	1TVM2A1	1TVM2A1	1TVM2A1	1TVM702	1TVM703	1TVM703	1TVM2C1
Factory R-22 Charge, lbs-oz	5 - 9	6 - 0	8 - 2	9 - 6	14 - 0	14 - 3	16 - 5
Indoor Coil ^{2,3}	TXV ⁴ + Charge Adder, Oz						
HC30A3X	2A + 0	-	-	-	-	-	-
HC36B3X	-	2A + 0	2A + 0	-	-	-	-
HC42C3X	-	-	-	702 + 9	703 + 6*	-	-
HC60D3X	-	-	-	-	703 + 13	703 + 6*	2C + 0*
HD24A3X	-	-	-	-	-	-	-
HD36B3X	-	2A + 0	2A + 0	702 + 5	-	-	-
HD48C3X	-	-	-	-	703 + 0*	703 + 0*	-
HD60D3X	-	-	-	-	-	-	2C + 0*
UC24A3X	2A + 0	-	-	-	-	-	-
UC24B3X	2A + 0	-	-	-	-	-	-
UC30A3X	2A + 0	-	-	-	-	-	-
UC30B3X	2A + 0	-	-	-	-	-	-
UC36A3X	-	-	2A + 0	-	-	-	-
UC36B3X	-	-	2A + 0	-	-	-	-
UC36C3X	-	-	2A + 0	-	-	-	-
UC42B3X	-	-	-	702 + 0	-	-	-
UC42C3X	-	-	-	702 + 0	-	-	-
UC48C3X	-	-	-	702 + 12	703 + 9*	-	-
UC48D3X	-	-	-	702 + 12	703 + 9*	-	-
UC60C3X	-	-	-	-	703 + 13	703 + 6*	2C + 0*
UC60D3X	-	-	-	-	703 + 13	703 + 6*	2C + 0*
AHP24B3X	2A + 0	-	-	-	-	-	-
AHP30B3X	-	2A + 0	2A + 0	-	-	-	-
AHP42C3X	-	-	-	702 + 9	-	-	-
AHP/SHP48D3X	-	-	-	-	703 + 13	703 + 6*	-
AHP/SHP60D3X	-	-	-	702 + 17	703 + 13	703 + 6	2C + 0
AV24B3X	2A + 0	-	-	-	-	-	-
AV36C3X	-	2A + 0	2A + 0	702 + 9	-	-	-
AV/SV48D3X	-	-	-	-	703 + 13	703 + 6	-
AV/SV60D3X	-	-	-	-	703 + 13	703 + 6	2C + 0
F*FP040	-	-	2A + 0	-	-	-	-
F4FV060H06T2C	-	-	-	-	-	703 + 6	0

FOOTNOTES:

1. A TXV kit must be used with these coils to obtain system performance.
 2. Systems matched with furnace or air handlers not equipped with blower-off delays may require blower Time Delay Kit 2FD06700224.
 3. PC coils cannot be used in downflow or horizontal applications. FC coils cannot be used in horizontal applications.
 4. If no TXV is listed, the indoor coil has the correct valve factory installed.
- * Does not achieve 14 SEER with PSC furnaces. For ratings, see technical guide or visit www.aridirectory.org/ari/unitary.html

PROCEDURES:

1. Unit factory charge listed on the unit nameplate includes refrigerant for the condenser, the smallest evaporator and 15 feet of interconnecting line tubing.
2. Verify the TXV and additional charge required for specific evaporator coil in the system using the above table.
3. Additional charge for the amount of interconnecting line tubing greater than 15 feet at the rate specified in the table above.
4. Permanently mark the unit nameplate with the total system charge. Total System Charge = Base Charge (as shipped) + adder for evaporator + adder for line set.

COOLING CAPACITY - With Air Handler Coils

UNIT MODEL	AIR HANDLER		COIL MODEL ¹	COOLING				
	MODEL	W		RATED CFM	NET MBH		SEER	EER
					TOTAL	SENS.		
1 PH 14 SEER AC WITH MA								
H1RE018S06	MA08B	17	FC/MC24B	600	17.5	12.1	14.00	12.00
	MA08B	17	FC/MC30B	600	17.5	12.1	14.00	12.00
H4RE024S06	MA08B	17	FC/MC35B	800	23.0	16.6	14.00	12.00
H3RE030S06	MA12B	17	FC/MC36B	1000	29.0	20.0	14.00	12.00
H1RE036S06	MA14D	24	FC/MC42D	1200	35.0	25.6	14.00	11.50
	MA14D	24	FC/MC48D	1200	35.2	25.7	14.00	11.50
H2RE042S06	MA14D	24	FC/MC48D	1400	39.5	28.9	13.50	11.00
	MA14D	24	FC/MC60D	1400	40.5	29.6	14.00	11.50
	MA16C	21	FC60C	1400	40.5	29.6	14.00	11.50
H2RE048S06	MA16C	21	FC/MC48C	1600	45.0	33.2	13.50	11.00
	MA20D	24	FC/MC48D	1600	45.0	33.2	13.50	11.00
	MA16C	21	FC60C	1600	46.5	33.9	13.85	11.00
	MA20D	24	FC/MC60D	1600	46.5	33.9	13.85	11.00
	MA20D	24	MC61D	1600	47.0	34.3	14.00	11.50
H3RE060S06	MA20D	24	FC/MC60D	1800	55.0	38.5	14.00	12.00
	MA20D	24	MC61D	1800	55.5	38.9	14.00	11.50
1 PH 14 SEER AC WITH MV - VARIABLE SPEED								
H1RE018S06	MV12B	17	FC/MC24B	600	17.8	12.1	15.00	12.00
	MV12B	17	FC/MC30B	600	17.8	12.1	15.00	12.00
H4RE024S06	MV12B	17	FC/MC35B	800	23.4	16.7	15.00	12.00
H3RE030S06	MV12B	17	FC/MC36B	1000	29.4	19.9	15.00	12.00
	MV16C	21	FC/MC36C	1000	29.4	19.9	15.00	12.00
H1RE036S06	MV16C	21	FC/MC42C	1250	35.2	25.6	15.00	12.00
	MV16C	21	FC/MC48C	1285	36.0	25.7	15.00	12.00
H2RE042S06	MV16C	21	FC/MC48C	1420	40.5	28.9	14.50	12.00
	MV20D	24	FC/MC60D	1420	41.5	29.6	15.00	12.00
H2RE048S06	MV20D	24	FC/MC48D	1590	46.0	33.2	14.50	12.00
	MV20D	24	FC/MC60D	1600	47.0	33.9	14.65	12.00
H3RE060S06	MV20D	24	FC/MC60D	1800	55.0	37.5	14.25	12.00
	MV20D	24	MC61D	1800	55.5	37.9	14.25	12.00
1 PH 13 SEER AC WITH AV / SV / FV - VARIABLE SPEED								
H1RE018S06	AV24	17	–	600	17.8	12.1	15.00	12.00
H4RE024S06	AV36	21	–	800	23.4	16.7	15.00	12.00
H3RE030S06	AV36	21	–	1000	29.4	19.9	15.00	12.00
H1RE036S06	AV36	21	–	1200	35.2	25.6	15.00	12.00
H2RE042S06	AV/SV48	24	–	1400	40.5	29.0	15.00	12.00
	AV/SV60	24	–	1400	40.5	29.0	15.00	12.00
H2RE048S06	AV/SV48	24	–	1600	46.5	33.2	15.00	12.00
	AV/SV60	24	–	1600	46.0	33.2	15.00	12.00
	F*FV060	24	–	1625	46.5	34.9	15.00	12.50
H3RE060S06	AV/SV60	24	–	1800	55.0	37.5	14.25	11.50
	F*FV060	24	–	1850	55.0	39.2	14.10	11.50
1 PH 14 SEER AC WITH AHP / F*FP								
H1RE018S06	AHP24	17	–	655	18.0	12.7	15.00	12.00
H4RE024S06	AHP30	17	–	830	23.0	16.7	14.00	12.00
H3RE030S06	AHP30	17	–	1015	29.6	24.0	14.00	12.00
	F*FP040	21	–	1015	29.6	24.0	14.00	12.00
H1RE036S06	AHP36	21	–	1200	35.0	25.1	14.00	12.00
	AHP42	21	–	1200	35.0	25.1	14.00	11.50
H2RE042S06	AHP/SHP48	24	–	1400	40.5	29.8	14.00	12.00
	AHP/SHP60	24	–	1400	40.5	29.8	14.00	12.00
H2RE048S06	AHP/SHP48	24	–	1600	46.5	33.6	13.85	11.00
	AHP/SHP60	24	–	1600	46.5	33.6	14.00	12.00
H3RE060S06	AHP/SHP60	24	–	1850	55.0	39.2	14.00	12.00

Rated in accordance with DOE test procedures (Federal Register 12-27-79 and 3-18-88) and ARI Standards 210.

Cooling MBH based on 80°F entering air temperature, 50% RH, and rated air flow.

EER (Energy Efficiency Ratio) is the total cooling output in BTU's at 95°F outdoor ambient divided by the total electric power in watt-hours at those conditions.

SEER (Seasonal Energy Efficiency Ratio) is the total cooling output in BTU's during a normal annual usage period for cooling divided by the total electric power input in watt-hours during the same period.

1. MC coils available with a factory installed horizontal drain pan. See price pages for specific model number.

Go to www.ari.org/aridirectory for the latest additional matches.

COOLING CAPACITY - Upflow, Downflow & Horizontal Furnaces and Coils

UNIT MODEL	FURNACE		COIL MODEL	RATED CFM	COOLING			
	CFM RANGE (MIN.-MAX.)	W			NET MBH		SEER ¹	EER
					TOTAL	SENS.		
H1RE018S06	450 750	14,17	FC/MC/PC/UC24	600	17.5	12.1	14.00	12.00
		14,17	FC/MC/PC/UC30	600	17.5	12.1	14.00	12.00
		14	HC30	600	17.3	12.1	14.00	12.00
H4RE024S06	600 1000	17, 21	FC/MC/PC35	800	23.0	16.6	14.00	12.00
		17	HC36	800	23.2	16.6	14.00	12.00
		–	HD36	800	23.4	16.6	14.00	12.00
H3RE030S06	800 1200	14,17,21	FC/MC/PC/UC36	1000	29.0	20.0	14.00	12.00
		17	HC36	1000	29.6	20.5	14.00	12.00
		–	HD36	1000	30.0	20.7	14.00	12.00
H1RE036S06	1000 1400	17,21	FC/MC/PC/UC42	1200	35.0	25.6	14.00	12.00
		21,24	FC/MC/PC/UC48	1200	35.2	25.7	14.00	12.00
		21	HC48	1200	34.6	25.3	14.00	12.00
		–	HD48	1200	34.8	25.0	14.00	12.00
H2RE042S06	1200 1600	21,24	FC/MC/PC/UC48	1400	39.5	28.9	13.50	11.00
		21,24	FC/MC/PC/UC60	1400	40.5	29.6	14.00	12.00
		21	HC42	1400	39.0	28.4	13.00	11.00
		24	HC60	1400	40.0	29.6	14.00	12.00
		–	HD48	1400	39.0	28.4	13.25	11.00
		–	HD60	1400	40.0	28.4	14.00	12.00
H2RE048S06	1400 1800	21,24	FC/MC/PC/UC48	1600	45.0	33.2	13.50	11.00
		21,24	FC/MC/PC/UC60	1600	46.5	33.9	13.90	11.00
		21	HC48	1600	45.0	32.6	13.30	11.00
		24	HC60	1600	46.0	33.9	13.75	11.00
		–	HD48	1600	45.0	32.4	13.50	11.00
		–	HD60	1600	46.0	33.9	13.75	11.00
H3RE060S06	1600 2000	21,24	FC/MC/PC/UC60	1800	55.0	38.5	14.00	12.00
		24	HC60	1800	55.0	38.5	14.00	12.00
		–	HD60	1800	55.0	38.7	14.00	12.00
		24	MC61	1800	55.5	38.9	14.00	12.00

1. Requires a 2FD06700224 Blower Time Delay unless a standard furnace is equipped with one.

COOLING CAPACITY - With Variable Speed Furnaces

UNIT MODEL	VARIABLE SPEED FURNACE MODEL	COIL MODEL ¹	W	COOLING				
				RATED CFM	NET MBH		SEER	EER
					TOTAL	SENS.		
1 PH 14 SEER AC WITH VARIABLE SPEED FURNACES²								
H1RE018S06	PV8*A12	FC/MC/PC24A	14	600	17.9	12.3	15.00	12.00
	PV9*A12	FC/MC/PC24A	14	600	17.8	12.2	15.00	12.00
	P(C,V)9*B12	FC/MC/PC24B	17	600	17.9	12.3	15.00	12.00
	PV8*A12	FC/MC/PC30A	14	600	17.9	12.3	15.00	12.00
	PV9*A12	FC/MC/PC30A	14	600	17.8	12.2	15.00	12.00
	P(C,V)9*B12	FC/MC/PC30B	17	600	17.9	12.3	15.00	12.00
	PV8*A12	HC30	14	600	17.7	12.2	15.00	12.00
H4RE024S06	P(C,V)9*B12	FC/MC/PC35B	17	800	23.2	17.2	14.00	12.00
	P(C,V)9*B12	HC36	17	800	23.6	17.4	14.00	12.00
	PV8*A12	HD36	-	800	24.0	17.7	14.00	12.00
	PV9*A12	HD36	-	800	24.0	17.7	14.00	12.00
H3RE030S06	PV8*A12	FC/MC/PC36A	14	1000	29.2	20.1	14.75	12.00
	PV9*A12	FC/MC/PC36A	14	1000	29.2	20.1	14.75	12.00
	PV8*B16	FC/MC/PC36B	17	1000	29.4	20.2	15.00	12.00
	P(C,V)9*B12	FC/MC/PC36B	17	1000	29.2	20.1	15.00	12.00
	PV8*C16	FC/MC/PC36C	21	1000	29.4	20.2	15.00	12.00
	PV8*C20	FC/MC/PC36C	21	1000	29.4	20.2	15.00	12.00
	P(C,V)9*C16	FC/MC/PC36C	21	1000	29.4	20.2	15.00	12.00
	PV8*B16	HC36	17	1000	30.0	20.7	15.00	12.00
	P(C,V)9*B12	HC36	17	1000	30.0	20.6	15.00	12.00
	PV8*A12	HD36	-	1000	30.0	20.8	15.00	12.00
	PV8*B16	HD36	-	1000	30.0	20.9	15.00	12.00
	PV8*C16	HD36	-	1000	30.0	20.9	15.00	12.00
	PV8*C20	HD36	-	1000	30.0	20.9	15.00	12.00
	PV9*A12	HD36	-	1000	30.0	20.8	15.00	12.00
	P(C,V)9*B12	HD36	-	1000	30.0	20.8	15.00	12.00
	P(C,V)9*C16	HD36	-	1000	30.0	20.9	15.00	12.00
H1RE036S06	PV8*B16	FC/MC/PC42B	17	1200	35.2	24.9	14.50	12.00
	P(C,V)9*B12	FC/MC/PC42B	17	1200	35.2	24.9	14.50	12.00
	PV8*C16	FC/MC/PC42C	21	1200	35.2	24.9	14.50	12.00
	PV8*C20	FC/MC/PC42C	21	1200	35.2	24.9	14.50	12.00
	P(C,V)9*C16	FC/MC/PC42C	21	1200	35.2	24.9	14.50	12.00
	P(C,V)9*C20	FC/MC/PC42C	21	1200	35.2	24.9	14.50	12.00
	PV8*C16	FC/MC/PC48C	21	1200	36.0	25.5	15.00	12.00
	PV8*C20	FC/MC/PC48C	21	1200	36.0	25.5	15.00	12.00
	P(C,V)9*C16	FC/MC/PC48C	21	1200	35.6	25.2	15.00	12.00
	P(C,V)9*C20	FC/MC/PC48C	21	1200	35.6	25.2	15.00	12.00
	P(C,V)9*D20	FC/MC/PC48D	24	1200	35.6	25.2	15.00	12.00
	PV8*C16	HC48	21	1200	35.2	24.9	14.50	12.00
	PV8*C20	HC48	21	1200	35.2	24.9	14.50	12.00
	P(C,V)9*C16	HC48	21	1200	35.2	24.9	14.50	12.00
	P(C,V)9*C20	HC48	21	1200	35.2	24.9	14.50	12.00
	PV8*C16	HD48	-	1200	35.2	24.9	14.50	12.00
	PV8*C20	HD48	-	1200	35.2	24.9	14.50	12.00
	P(C,V)9*C16	HD48	-	1200	35.2	24.9	14.50	12.00
	P(C,V)9*C20	HD48	-	1200	35.2	24.9	14.50	12.00

For Notes See Page 9.

COOLING CAPACITY - With Variable Speed Furnaces (Continued)

UNIT MODEL	VARIABLE SPEED FURNACE MODEL	COIL MODEL ¹	W	COOLING				
				RATED CFM	NET MBH		SEER	EER
					TOTAL	SENS.		
1 PH 14 SEER AC WITH VARIABLE SPEED FURNACES²								
H2RE042S06	PV8*C16	FC/MC/PC48C	21	1420	40.0	28.8	14.00	12.00
	PV8*C20	FC/MC/PC48C	21	1420	40.0	28.8	14.50	12.00
	P(C,V)9*C16	FC/MC/PC48C	21	1400	39.5	28.4	14.00	12.00
	P(C,V)9*C20	FC/MC/PC48C	21	1400	39.5	28.4	14.00	12.00
	P(C,V)9*D20	FC/MC/PC48D	24	1400	39.5	28.4	14.00	12.00
	P(C,V)9*D20	FC/MC/PC60D	24	1400	40.5	29.1	14.50	12.00
	PV8*C16	FC/PC60C	21	1420	40.0	28.8	14.00	12.00
	PV8*C20	FC/PC60C	21	1400	41.0	29.5	14.50	12.00
	P(C,V)9*C16	FC/PC60C	21	1400	40.5	29.1	14.50	12.00
	P(C,V)9*C20	FC/PC60C	21	1400	40.5	29.1	14.50	12.00
	PV8*C20	HC60	24	1400	41.0	29.5	14.50	12.00
	P(C,V)9*D20	HC60	24	1400	40.5	29.1	14.50	12.00
	PV8*C20	HD60	–	1400	41.0	29.5	14.50	12.00
	P(C,V)9*C20	HD60	–	1400	40.5	29.1	14.50	12.00
P(C,V)9*D20	HD60	–	1400	40.5	29.1	14.50	12.00	
H2RE048S06	P(C,V)9*D20	FC/MC/PC60D	24	1600	46.5	33.9	14.25	12.00
	PV8*C20	FC/PC60C	21	1605	46.5	33.9	14.00	12.00
	P(C,V)9*C20	FC/PC60C	21	1600	46.5	33.9	14.00	12.00
	PV8*C20	MC60D	24	1605	46.5	33.9	14.00	12.00
	P(C,V)9*C20	MC60D	24	1600	46.5	33.9	14.00	12.00
	PV8*C20	MC61D	24	1600	47.0	34.3	14.25	12.00
	P(C,V)9*C20	MC61D	24	1600	47.0	34.3	14.25	12.00
P(C,V)9*D20	MC61D	24	1600	47.0	34.3	14.25	12.00	
H3RE060S06	P(C,V)9*D20	FC/MC/PC60D	24	1620	54.5	36.8	14.25	12.00
	PV8*C20	FC/PC60C	21	1730	54.0	37.8	14.00	12.00
	P(C,V)9*C20	FC/PC60C	21	1620	54.5	36.7	14.00	12.00
	PV8*C20	HC60	24	1730	54.0	37.8	14.00	12.00
	P(C,V)9*D20	HC60	24	1620	54.5	36.8	14.25	11.50
	PV8*C20	HD60	–	1730	55.0	38.0	14.00	12.00
	P(C,V)9*C20	HD60	–	1620	54.5	36.8	14.00	11.50
	P(C,V)9*D20	HD60	–	1620	55.0	37.0	14.25	11.50
	PV8*C20	MC61D	24	1730	55.5	38.1	14.00	12.00
	P(C,V)9*C20	MC61D	24	1620	55.0	37.1	14.00	11.50
P(C,V)9*D20	MC61D	24	1620	55.0	37.1	14.25	11.50	

1. MC coils available with a factory installed horizontal drain pan. See price pages for specific model number.
2. Variable speed furnaces have B.O.D (Blower on Delay) standard.

ACCESSORIES

Refer to Price Manual for specific model numbers.

Compressor Blanket - Designed to further reduce the normal operating sound and is required to meet Canadian sound levels for units of three tons and below.

Refer to Price Manual for specific model numbers.

Blower Time Delay - Available to increase efficiency when installed. Installs on indoor section and maintains blower for approximately one minute after cooling thermostat has been satisfied.

TXV KIT - 1TVM series TXV's must be used to obtain system performance. See Tabular Data Sheet for proper selection.

ROOM THERMOSTATS - A wide selection of compatible thermostats are available to provide optimum performance and features for any installation.

1H/1C, manual changeover electronic non-programmable thermostat.

1H/1C, auto/manual changeover, electronic programmable, deluxe 7-day, thermostat.

1H/1C, auto/manual changeover, electronic programmable.

* For the most current accessory information, refer to the price book or consult factory.

SOUND POWER RATINGS*

UNIT MODEL	(dBA)
024	75
030	76
036	76
042	76
048	76
060	76

* Rated in accordance with ARI 270-95 Standards.

TYPICAL INSTALLATION

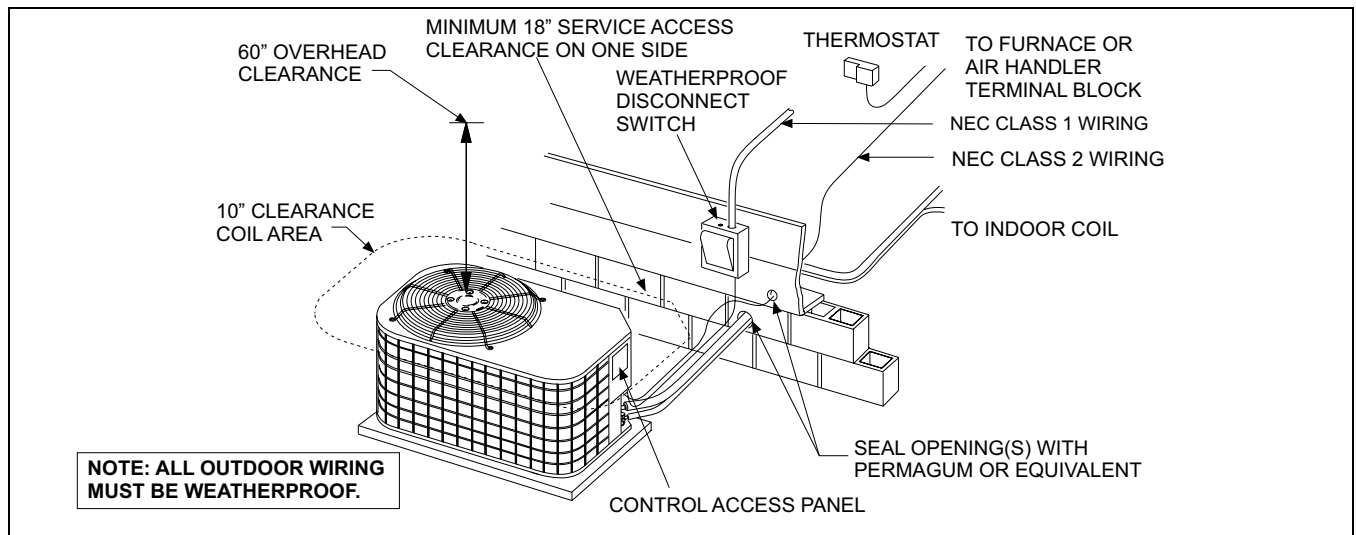

TYPICAL FIELD WIRING

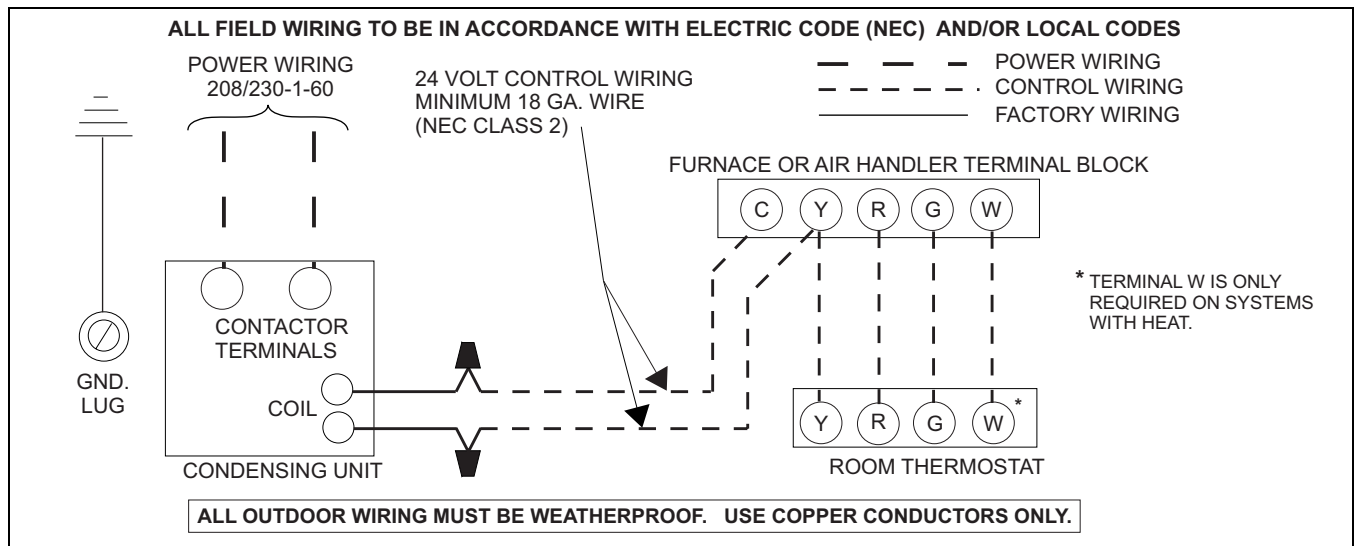

COOLING PERFORMANCE DATA																
AIR CONDITIONER MODEL NO.		H1RE018S06														
INDOOR COIL MODEL NO.		FC/MC/PC/UC24														
CONDENSER ENTERING AIR TEMPERATURE	ID CFM	450					600					750				
	ID DB	80	80	75	80	80	80	80	75	80	80	80	80	75	80	80
	ID WB	57	62	62	67	72	57	62	62	67	72	57	62	62	67	72
65	T.C.	14.9	18.9	17.9	20.4	22.6	16.9	20.5	19.3	22.0	22.9	19.0	22.1	20.8	23.6	23.2
	S.C.	14.6	14.2	11.9	12.2	10.3	16.6	16.7	14.1	14.5	11.4	18.6	19.3	16.2	16.8	12.5
	K.W.	1.0	1.0	1.0	1.0	1.0	1.0	1.0	1.0	1.0	1.0	1.0	1.0	1.0	1.0	1.0
75	T.C.	14.5	17.8	17.0	19.2	21.0	16.3	19.4	18.3	20.7	21.4	18.1	20.9	19.5	22.1	21.8
	S.C.	14.2	13.7	11.6	11.7	9.7	16.0	16.1	13.5	13.9	10.9	17.7	18.5	15.5	16.0	12.0
	K.W.	1.0	1.1	1.1	1.1	1.1	1.1	1.1	1.1	1.1	1.1	1.1	1.1	1.1	1.1	1.1
85	T.C.	14.0	16.8	16.1	18.0	19.4	15.6	18.2	17.2	19.3	19.9	17.2	19.7	18.3	20.7	20.3
	S.C.	13.7	13.3	11.2	11.2	9.2	15.3	15.5	13.0	13.2	10.3	16.9	17.6	14.8	15.2	11.5
	K.W.	1.1	1.1	1.1	1.2	1.2	1.1	1.1	1.1	1.2	1.2	1.2	1.2	1.2	1.2	1.2
95	T.C.	13.6	15.7	15.2	16.9	17.8	15.0	17.1	16.1	18.0	18.3	16.4	18.5	17.0	19.2	18.9
	S.C.	13.3	12.8	10.8	10.8	8.6	14.7	14.8	12.4	12.6	9.8	16.0	16.8	14.0	14.4	11.0
	K.W.	1.2	1.2	1.2	1.2	1.3	1.2	1.2	1.2	1.3	1.3	1.2	1.2	1.2	1.3	1.3
105	T.C.	12.7	14.7	14.1	15.7	16.5	14.1	16.2	15.0	16.8	16.9	15.4	17.7	15.9	17.8	17.3
	S.C.	12.4	12.4	10.3	10.4	8.3	13.8	14.2	11.9	11.9	9.4	15.1	16.0	13.5	13.5	10.5
	K.W.	1.3	1.3	1.3	1.3	1.4	1.3	1.3	1.3	1.3	1.4	1.3	1.3	1.3	1.4	1.4
115	T.C.	11.8	13.8	13.0	14.6	15.3	13.2	15.3	13.9	15.6	15.5	14.5	16.9	14.8	16.5	15.7
	S.C.	11.5	11.9	9.9	10.0	7.9	12.9	13.6	11.4	11.3	9.0	14.3	15.2	13.0	12.5	10.0
	K.W.	1.4	1.4	1.4	1.4	1.5	1.4	1.4	1.4	1.4	1.5	1.4	1.4	1.4	1.5	1.5
125	T.C.	10.9	12.8	12.0	13.5	14.1	12.3	14.4	12.8	14.3	14.1	13.6	16.1	13.7	15.1	14.1
	S.C.	10.7	11.5	9.4	9.6	7.6	12.0	13.0	10.9	10.6	8.5	13.4	14.5	12.4	11.6	9.5
	K.W.	1.4	1.4	1.4	1.5	1.6	1.5	1.5	1.5	1.5	1.6	1.5	1.5	1.5	1.6	1.6

NOTE: ALL CAPACITIES INCLUDE INDOOR FAN HEAT AT 1250 BTUH/1000 CFM.

Multipliers for determining the performance with other indoor sections.

NOTE: For dry bulb temperatures different than those listed (between 73-87 F), sensible capacity increases by 1060 BTUH per 1000 CFM per degree above the listed temperature and decreases by 1060 BTUH per 1000 CFM per degree below the listed temperature.

Air Handler	Coil	T.C.	S.C.	KW
AHP24	–	1.01	1.05	1.01
AV24	–	1.02	1.00	0.97
MA08B	FC/MC24B	1.00	1.00	1.00
MA08B	FC/MC30B	1.00	1.00	1.00
MV12B	FC/MC24B	1.02	1.00	0.97
MV12B	FC/MC30B	1.02	1.00	0.97
–	FC/MC/PC/UC30	1.00	1.00	1.00
–	HC30	0.99	1.00	1.00

Variable Speed Furnace	Coil	T.C.	S.C.	KW
PV8*A12	FC/MC/PC24A	1.02	1.02	0.98
PV8*A12	FC/MC/PC30A	1.02	1.02	0.98
PV8*A12	HC30	1.01	1.01	0.97
PV9*A12	FC/MC/PC24A	1.02	1.01	0.97
PV9*A12	FC/MC/PC30A	1.02	1.01	0.97
P(C,V)9*B12	FC/MC/PC24B	1.02	1.02	0.98
P(C,V)9*B12	FC/MC/PC30B	1.02	1.02	0.98

COOLING PERFORMANCE DATA																
AIR CONDITIONER MODEL NO.		H4RE024S06														
INDOOR COIL MODEL NO.		FC/MC/PC35														
CONDENSER ENTERING AIR TEMPERATURE	ID CFM	600					800					1000				
	ID DB	80	80	75	80	80	80	80	75	80	80	80	80	75	80	80
	ID WB	57	62	62	67	72	57	62	62	67	72	57	62	62	67	72
65	T.C.	20.1	22.8	25.9	27.9	23.1	24.6	26.9	29.0	26.1	26.4	27.9	30.2	25.6	27.9	30.2
	S.C.	19.9	17.8	16.4	12.9	22.8	21.5	18.9	14.6	25.7	25.2	21.5	16.4	21.0	21.5	16.4
	K.W.	1.2	1.3	1.3	1.3	1.3	1.3	1.3	1.3	1.3	1.3	1.3	1.3	1.3	1.3	1.3
75	T.C.	19.3	21.6	24.8	26.8	22.0	23.3	25.8	27.8	24.8	25.1	26.8	28.8	24.3	26.8	28.8
	S.C.	19.1	17.4	15.8	12.5	21.8	20.8	18.1	14.1	24.5	24.2	20.4	15.6	20.6	20.4	15.6
	K.W.	1.3	1.4	1.4	1.4	1.4	1.4	1.4	1.4	1.4	1.4	1.4	1.4	1.4	1.4	1.4
85	T.C.	18.5	20.3	23.7	25.7	21.0	22.1	24.7	26.5	23.5	23.8	25.8	27.4	23.0	25.8	27.4
	S.C.	18.3	16.9	15.3	12.1	20.7	20.0	17.3	13.5	23.2	23.2	19.4	14.9	20.1	19.4	14.9
	K.W.	1.4	1.5	1.5	1.5	1.5	1.5	1.5	1.6	1.5	1.5	1.5	1.6	1.5	1.5	1.6
95	T.C.	17.6	19.1	22.6	24.6	19.9	20.8	23.7	25.3	22.2	22.6	24.7	25.9	21.7	24.7	25.9
	S.C.	17.4	16.4	14.7	11.6	19.7	19.3	16.5	12.9	22.0	22.2	18.3	14.1	19.7	18.3	14.1
	K.W.	1.6	1.6	1.6	1.7	1.6	1.6	1.7	1.7	1.6	1.6	1.7	1.7	1.6	1.7	1.7
105	T.C.	16.8	18.2	20.8	22.8	18.8	19.6	21.6	23.4	20.7	21.1	22.5	24.0	20.1	22.5	24.0
	S.C.	16.7	16.2	14.0	11.0	18.6	18.5	16.0	12.3	20.6	20.9	18.0	13.5	18.7	18.0	13.5
	K.W.	1.7	1.7	1.8	1.8	1.7	1.7	1.8	1.8	1.8	1.8	1.8	1.8	1.7	1.8	1.8
115	T.C.	16.0	17.4	19.0	21.1	17.7	18.4	19.7	21.6	19.3	19.4	20.4	22.1	18.6	20.4	22.1
	S.C.	15.9	16.0	13.4	10.4	17.6	17.6	15.5	11.7	19.3	19.4	17.7	12.9	17.7	17.7	12.9
	K.W.	1.8	1.8	1.9	1.9	1.8	1.8	1.9	1.9	1.9	1.9	1.9	2.0	1.9	1.9	2.0
125	T.C.	15.2	16.5	17.3	19.4	16.6	17.2	17.7	19.8	17.9	18.3	19.2	20.1	17.1	18.2	20.1
	S.C.	15.2	14.7	12.7	9.9	16.6	16.6	15.0	11.1	17.0	18.0	17.3	12.3	16.8	17.3	12.3
	K.W.	1.9	1.9	2.0	2.0	2.0	2.0	2.0	2.1	2.0	2.0	2.0	2.1	2.0	2.0	2.1

NOTE: ALL CAPACITIES INCLUDE INDOOR FAN HEAT AT 1250 BTUH/1000 CFM.

Multipliers for determining the performance with other indoor sections.

NOTE: For dry bulb temperatures different than those listed (between 73-87 F), sensible capacity increases by 1060 BTUH per 1000 CFM per degree above the listed temperature and decreases by 1060 BTUH per 1000 CFM per degree below the listed temperature.

Air Handler	Coil	T.C.	S.C.	KW
AHP30	–	1.00	1.00	1.00
AV36	–	1.00	1.00	1.00
MA12B	FC/MC35B	1.01	1.00	0.97
MV12B	FC/MC35B	1.01	1.00	0.97
–	HC36	1.00	1.00	1.00
–	HD36	1.00	1.00	1.00

Variable Speed Furnace	Coil	T.C.	S.C.	KW
P(C,V)9*B12	FC/MC/PC35B	1.01	1.00	0.97
P(C,V)9*B12	HC36	1.01	1.00	0.97
PV8*B12	HD36	1.01	1.00	0.97
P(C,V)9*B12	HD36	1.01	1.00	0.97

COOLING PERFORMANCE DATA																	
AIR CONDITIONER MODEL NO.		H3RE030S06															
INDOOR COIL MODEL NO.		FC/MC/PC/UC36															
CONDENSER ENTERING AIR TEMPERATURE	ID CFM	800					1000					1200					
		ID DB	80	80	75	80	80	80	80	75	80	80	80	80	75	80	80
		ID WB	57	62	62	67	72	57	62	62	67	72	57	62	62	67	72
65	T.C.	27.4	30.6	30.1	33.7	38.0	29.1	31.6	31.1	34.6	38.8	30.8	32.5	32.1	35.5	39.5	
	S.C.	27.3	24.2	20.2	20.1	16.7	28.8	27.1	22.4	22.4	18.1	30.2	30.0	24.6	24.6	19.4	
	K.W	1.5	1.5	1.5	1.5	1.6	1.5	1.5	1.5	1.6	1.6	1.5	1.5	1.5	1.6	1.6	
75	T.C.	26.4	28.9	28.7	32.0	36.0	27.9	29.8	29.6	32.8	36.8	29.4	30.7	30.6	33.6	37.6	
	S.C.	25.9	23.3	19.6	19.5	16.0	27.4	26.0	21.8	21.7	17.4	28.9	28.7	24.0	23.8	18.8	
	K.W	1.7	1.7	1.7	1.7	1.7	1.7	1.7	1.7	1.7	1.7	1.7	1.7	1.7	1.7	1.7	
85	T.C.	25.5	27.2	27.3	30.3	34.0	26.7	28.0	28.2	31.0	34.8	28.0	28.8	29.0	31.7	35.7	
	S.C.	24.4	22.4	19.0	19.0	15.3	26.0	24.9	21.2	21.0	16.7	27.6	27.4	23.5	23.0	18.1	
	K.W	1.8	1.9	1.9	1.9	1.9	1.9	1.9	1.9	1.9	1.9	1.9	1.9	1.9	1.9	1.9	
95	T.C.	24.5	25.5	25.9	28.6	32.0	25.5	26.2	26.7	29.2	32.9	26.6	27.0	27.5	29.8	33.8	
	S.C.	23.0	21.5	18.4	18.4	14.6	24.7	23.8	20.7	20.3	16.0	26.4	26.1	22.9	22.2	17.5	
	K.W	2.0	2.0	2.0	2.1	2.1	2.0	2.0	2.0	2.1	2.1	2.0	2.0	2.0	2.1	2.1	
105	T.C.	23.0	24.4	24.1	26.7	30.0	24.1	24.9	24.8	27.2	30.6	25.1	25.4	25.5	27.7	31.3	
	S.C.	21.9	20.5	17.7	17.7	14.0	23.4	22.7	19.8	19.6	15.3	24.8	24.8	21.9	21.5	16.6	
	K.W	2.2	2.2	2.2	2.2	2.3	2.2	2.2	2.2	2.2	2.3	2.2	2.2	2.2	2.3	2.3	
115	T.C.	21.6	23.4	22.4	24.9	28.0	22.6	23.6	23.0	25.3	28.4	23.6	23.9	23.6	25.7	28.9	
	S.C.	20.8	19.5	17.0	17.0	13.5	22.1	21.5	19.0	19.0	14.6	23.4	23.6	21.0	20.9	15.8	
	K.W	2.3	2.3	2.3	2.4	2.5	2.3	2.4	2.3	2.4	2.5	2.4	2.4	2.4	2.4	2.5	
125	T.C.	20.2	22.3	20.7	23.1	26.0	21.2	22.4	21.2	23.4	26.3	22.2	22.4	21.7	23.7	26.5	
	S.C.	19.7	18.5	16.3	16.4	12.9	20.8	20.4	18.2	18.3	14.0	21.9	22.4	20.1	20.3	15.0	
	K.W	2.5	2.5	2.5	2.5	2.6	2.5	2.5	2.5	2.6	2.7	2.6	2.6	2.5	2.6	2.7	

NOTE: ALL CAPACITIES INCLUDE INDOOR FAN HEAT AT 1250 BTUH/1000 CFM.

Multipliers for determining the performance with other indoor sections.

NOTE: For dry bulb temperatures different than those listed (between 73-87 F), sensible capacity increases by 1060 BTUH per 1000 CFM per degree above the listed temperature and decreases by 1060 BTUH per 1000 CFM per degree below the listed temperature.

Air Handler	Coil	T.C.	S.C.	KW
AHP30	-	1.02	1.20	1.02
AV36	-	1.01	1.00	0.97
F*FP040	-	1.02	1.20	1.02
MA12B	FC/MC36B	1.00	1.00	1.00
MV12B	FC/MC36B	1.01	1.00	0.97
MV16C	FC/MC36C	1.01	1.00	0.97
-	HC36	1.02	1.03	1.02
-	HD36	1.03	1.04	1.03

Variable Speed Furnace	Coil	T.C.	S.C.	KW
PV8*A12	FC/MC/PC36A	1.01	1.01	1.01
PV8*A12	HD36	1.03	1.04	0.99
PV8*B16	FC/MC/PC36B	1.01	1.01	0.97
PV8*B16	HC36	1.03	1.04	0.99
PV8*B16	HD36	1.03	1.05	0.99
PV8*C16	FC/MC/PC36C	1.01	1.01	0.97
PV8*C16	HD36	1.03	1.05	0.99
PV8*C20	FC/MC/PC36C	1.01	1.01	0.97
PV8*C20	HD36	1.03	1.05	0.99
PV9*A12	FC/MC/PC36A	1.01	1.01	1.01
PV9*A12	HD36	1.03	1.04	0.99
P(C,V)9*B12	FC/MC/PC36B	1.01	1.01	0.96
P(C,V)9*B12	HC36	1.03	1.03	0.99
P(C,V)9*B12	HD36	1.03	1.04	0.99
P(C,V)9*C16	FC/MC/PC36C	1.01	1.01	0.97
P(C,V)9*C16	HD36	1.03	1.05	0.99

COOLING PERFORMANCE DATA										
AIR CONDITIONER MODEL NO.		H1RE036S06								
INDOOR COIL MODEL NO.		AHP42								
CONDENSER ENTERING AIR TEMPERATURE	ID CFM	1000			1200			1400		
	ID DB	85	80	70	85	80	70	85	80	70
	ID WB	72	67	57	72	67	57	72	67	57
75	T.C.	40.0	36.9	34.3	41.3	38.1	35.7	42.0	38.9	36.7
	S.C.	25.4	24.4	23.4	27.6	26.3	25.5	29.6	27.9	27.2
	K.W.	1.98	1.96	1.94	1.99	1.97	1.95	2.00	1.98	1.96
85	T.C.	38.6	35.6	32.7	39.6	36.6	34.0	40.2	37.3	34.9
	S.C.	24.8	23.8	22.8	27.0	25.8	24.9	29.1	27.6	26.6
	K.W.	2.21	2.18	2.17	2.22	2.19	2.18	2.23	2.20	2.19
95	T.C.	37.2	34.2	31.0	37.8	35.2	32.4	38.4	35.8	33.0
	S.C.	24.2	23.3	22.3	26.4	25.3	24.2	28.5	27.2	25.9
	K.W.	2.44	2.41	2.40	2.45	2.42	2.41	2.46	2.42	2.42
105	T.C.	35.5	32.3	29.6	36.1	33.1	30.6	36.7	33.7	31.2
	S.C.	23.5	22.6	21.7	25.6	24.6	23.5	27.6	26.5	25.3
	K.W.	2.75	2.72	2.72	2.75	2.73	2.72	2.76	2.73	2.73
115	T.C.	33.7	30.4	28.1	34.4	31.1	28.7	35.0	31.7	29.4
	S.C.	22.8	21.8	21.1	24.7	23.9	22.8	26.8	25.8	24.6
	K.W.	3.06	3.04	3.03	3.06	3.04	3.02	3.07	3.04	3.03
125	T.C.	31.9	28.5	26.7	32.7	29.1	26.9	33.3	29.7	27.6
	S.C.	22.2	21.1	20.5	23.9	23.1	22.1	25.9	25.1	24.0
	K.W.	3.37	3.36	3.34	3.37	3.35	3.32	3.38	3.35	3.33

NOTE: ALL CAPACITIES INCLUDE INDOOR FAN HEAT AT 1250 BTUH/1000 CFM.

Multipliers for determining the performance with other indoor sections.

NOTE: For dry bulb temperatures different than those listed (between 73-87 F), sensible capacity increases by 1060 BTUH per 1000 CFM per degree above the listed temperature and decreases by 1060 BTUH per 1000 CFM per degree below the listed temperature.

Air Handler	Coil	T.C.	S.C.	KW
AV36	–	1.00	1.01	1.07
MA14D	FC/MC42D	0.99	1.01	1.06
MA14D	FC/MC48D	1.00	1.02	1.07
MV16C	FC/MC42C	1.00	1.01	1.07
MV16C	FC/MC48C	1.02	1.02	1.09
–	FC/MC/PC/UC42	0.99	1.01	1.06
–	FC/MC/PC/UC48	1.00	1.02	1.07
–	HC48	0.98	1.00	1.05
–	HD48	0.99	0.99	1.06

Variable Speed Furnace	Coil	T.C.	S.C.	KW
PV8*B16	FC/MC/PC42B	1.00	0.98	1.07
PV8*C16	FC/MC/PC42C	1.00	0.98	1.07
PV8*C16	FC/MC/PC48C	1.02	1.01	1.09
PV8*C16	HC48	1.00	0.98	1.07
PV8*C16	HD48	1.00	0.98	1.07
PV8*C20	FC/MC/PC42C	1.00	0.98	1.07
PV8*C20	FC/MC/PC48C	1.02	1.01	1.09
PV8*C20	HC48	1.00	0.98	1.07
PV8*C20	HD48	1.00	0.98	1.07
P(C,V)9*B12	FC/MC/PC42B	1.00	0.98	1.07
P(C,V)9*C16	FC/MC/PC42C	1.00	0.98	1.07
P(C,V)9*C16	FC/MC/PC48C	1.01	1.00	1.08
P(C,V)9*C16	HC48	1.00	0.98	1.07
P(C,V)9*C16	HD48	1.00	0.98	1.07
P(C,V)9*C20	FC/MC/PC42C	1.00	0.98	1.07
P(C,V)9*C20	FC/MC/PC48C	1.01	1.00	1.08
P(C,V)9*C20	HC48	1.00	0.98	1.07
P(C,V)9*C20	HD48	1.00	0.98	1.07
P(C,V)9*D20	FC/MC/PC48D	1.01	1.00	1.08

COOLING PERFORMANCE DATA													
AIR CONDITIONER MODEL NO.		H2RE042S06											
INDOOR COIL MODEL NO.		FC/MC/PC/UC60											
CONDENSER ENTERING AIR TEMPERATURE	ID CFM	1300				1450				1550			
	ID DB	85	80	75	70	85	80	75	70	85	80	75	70
	ID WB	72	67	62	57	72	67	62	57	72	67	62	57
75	T.C.	47.3	43.8	40.3	37.2	47.7	44.3	40.9	37.7	48.0	44.5	41.2	38.0
	S.C.	28.3	28.5	28.9	29.2	29.8	30.0	30.6	30.7	30.8	31.0	31.6	31.7
	K.W.	2.88	2.84	2.80	2.77	2.95	2.90	2.87	2.84	3.00	2.95	2.91	2.88
85	T.C.	44.6	41.3	38.1	35.1	45.0	41.8	38.6	35.5	45.2	42.1	38.8	35.9
	S.C.	27.4	27.6	28.1	28.2	29.0	29.2	29.6	29.8	30.0	30.2	30.6	30.8
	K.W.	3.14	3.10	3.06	3.04	3.20	3.16	3.13	3.11	3.25	3.21	3.17	3.15
95	T.C.	42.2	39.0	36.0	33.1	42.5	39.5	36.4	33.7	42.8	39.7	36.6	33.9
	S.C.	26.6	26.8	27.2	27.4	28.2	28.4	28.7	28.9	29.3	29.4	29.7	29.8
	K.W.	3.45	3.41	3.39	3.37	3.52	3.48	3.45	3.43	3.56	3.52	3.49	3.47
105	T.C.	39.7	36.8	33.9	31.2	40.1	37.2	34.2	31.8	40.3	37.3	34.4	32.2
	S.C.	25.9	26.1	26.4	26.6	27.5	27.6	27.9	28.2	28.5	28.5	28.9	28.6
	K.W.	3.82	3.79	3.77	3.75	3.89	3.86	3.83	3.81	3.93	3.90	3.87	3.85
115	T.C.	37.2	34.5	31.7	29.3	37.6	34.8	32.1	30.0	37.8	35.0	32.3	30.3
	S.C.	25.1	25.2	25.5	25.6	26.7	26.7	27.1	26.6	27.7	27.7	27.9	26.9
	K.W.	4.26	4.23	4.21	4.19	4.32	4.29	4.27	4.26	4.36	4.34	4.31	4.30
125	T.C.	34.7	32.2	29.5	27.4	35.1	32.4	30.0	28.2	35.3	32.7	30.2	28.4
	S.C.	24.3	24.3	24.6	24.6	25.9	25.8	26.3	25.0	26.9	26.9	26.9	25.2
	K.W.	4.70	4.67	4.65	4.63	4.75	4.72	4.71	4.71	4.79	4.78	4.75	4.75

NOTE: ALL CAPACITIES INCLUDE INDOOR FAN HEAT AT 1250 BTUH/1000 CFM.

Multipliers for determining the performance with other indoor sections.

NOTE: For dry bulb temperatures different than those listed (between 73-87 F), sensible capacity increases by 1060 BTUH per 1000 CFM per degree above the listed temperature and decreases by 1060 BTUH per 1000 CFM per degree below the listed temperature.

Air Handler	Coil	T.C.	S.C.	KW
AHP/SHP48	-	1.00	1.01	1.00
AV/SV48	-	1.00	1.01	0.96
AV/SV60	-	1.00	1.01	0.96
AHP/SHP60	-	1.00	1.01	0.96
MA14D	FC/MC48D	0.98	0.98	1.02
MA14D	FC/MC60D	1.00	1.00	1.00
MA16C	FC60C	1.00	1.00	1.00
MV16C	FC/MC48C	1.00	0.98	1.00
MV20D	FC/MC60D	1.02	1.00	1.02
-	FC/MC/PC/UC48	0.98	0.98	1.02
-	HC48	0.96	0.96	1.01
-	HC60	0.99	1.00	0.99
-	HD48	0.96	0.96	1.01
-	HD60	0.99	0.96	0.99

Variable Speed Furnace	Coil	T.C.	S.C.	KW
PV8*C16	FC/MC/PC48C	0.99	0.97	0.99
PV8*C16	FC/PC60C	0.99	0.97	0.99
PV8*C20	FC/MC/PC48C	0.99	0.97	0.99
PV8*C20	FC/PC60C	1.01	1.00	1.01
PV8*C20	HC60	1.01	1.00	1.01
PV8*C20	HD60	1.01	1.00	1.01
P(C,V)9*C16	FC/MC/PC48C	0.98	0.96	0.98
P(C,V)9*C16	FC/PC60C	1.00	0.98	1.00
P(C,V)9*C20	FC/MC/PC48C	0.98	0.96	0.98
P(C,V)9*C20	FC/PC60C	1.00	0.98	1.00
P(C,V)9*C20	HD60	1.00	0.98	1.00
P(C,V)9*D20	FC/MC/PC48D	0.98	0.96	0.98
P(C,V)9*D20	FC/MC/PC60D	1.00	0.98	1.00
P(C,V)9*D20	HC60	1.00	0.98	1.00
P(C,V)9*D20	HD60	1.00	0.98	1.00

COOLING PERFORMANCE DATA										
AIR CONDITIONER MODEL NO.		H2RE048S06								
INDOOR COIL MODEL NO.		FC/MC/PC/UC60								
CONDENSER ENTERING AIR TEMPERATURE	ID CFM	1400			1600			1800		
	ID DB	85	80	70	85	80	70	85	80	70
	ID WB	72	67	57	72	67	57	72	67	57
75	T.C.	53.3	49.5	45.5	54.3	50.2	46.4	55.2	51.0	47.3
	S.C.	33.4	32.6	31.1	35.9	35.0	33.0	38.3	37.4	34.9
	K.W.	2.76	2.72	2.69	2.77	2.74	2.70	2.77	2.76	2.70
85	T.C.	51.2	47.7	43.9	52.0	48.4	44.8	52.8	49.1	45.7
	S.C.	33.1	32.1	30.6	35.4	34.5	32.6	37.7	36.8	34.6
	K.W.	3.07	3.04	3.01	3.07	3.05	3.02	3.08	3.06	3.03
95	T.C.	49.0	45.9	42.4	49.7	46.5	43.2	50.3	47.2	44.1
	S.C.	32.7	31.6	30.0	34.9	33.9	32.2	37.1	36.2	34.4
	K.W.	3.37	3.35	3.33	3.38	3.36	3.34	3.38	3.37	3.35
105	T.C.	46.6	43.5	40.1	47.3	44.1	40.8	48.0	44.7	41.6
	S.C.	31.7	30.7	29.0	34.0	32.9	31.2	36.3	35.1	33.3
	K.W.	3.78	3.75	3.74	3.79	3.76	3.75	3.79	3.77	3.75
115	T.C.	44.1	41.1	37.8	44.9	41.6	38.4	45.6	42.2	39.1
	S.C.	30.8	29.8	28.1	33.1	31.9	30.2	35.4	34.1	32.3
	K.W.	4.18	4.16	4.15	4.19	4.16	4.15	4.21	4.16	4.15
125	T.C.	41.7	38.7	35.5	42.5	39.2	36.0	43.3	39.7	36.6
	S.C.	29.8	28.8	27.1	32.2	31.0	29.2	34.6	33.1	31.3
	K.W.	4.59	4.56	4.56	4.60	4.56	4.55	4.62	4.56	4.55

NOTE: ALL CAPACITIES INCLUDE INDOOR FAN HEAT AT 1250 BTUH/1000 CFM.

Multipliers for determining the performance with other indoor sections.

NOTE: For dry bulb temperatures different than those listed (between 73-87 F), sensible capacity increases by 1060 BTUH per 1000 CFM per degree above the listed temperature and decreases by 1060 BTUH per 1000 CFM per degree below the listed temperature.

Air Handler	Coil	T.C.	S.C.	KW
AHP/SHP48	–	1.00	0.99	1.07
AHP/SHP60	–	1.00	0.99	1.03
AV/SV48	–	1.02	1.03	0.91
AV/SV60	–	1.02	1.03	0.91
F*FV060	–	1.02	1.03	0.91
MA16C	FC/MC48C	0.97	0.98	1.04
MA16C	FC60C	1.00	1.00	1.07
MA20D	FC/MC48D	0.97	0.98	1.04
MA20D	FC/MC60D	1.00	1.00	1.07
MA20D	MC61D	1.01	1.01	1.04
MV20D	FC/MC48D	0.99	0.98	1.02
MV20D	FC/MC60D	1.01	1.00	1.04
–	FC/MC/PC/UC48	0.97	0.98	1.04
–	HC48	0.97	0.96	1.04
–	HC60	0.99	1.00	1.06
–	HD48	0.97	0.96	1.04
–	HD60	0.99	1.00	1.06
–	MC61	1.01	1.01	1.04

Variable Speed Furnace	Coil	T.C.	S.C.	KW
PV8*C20	FC/PC60C	1.00	1.00	1.03
PV8*C20	MC60D	1.00	1.00	1.03
PV8*C20	MC61D	1.01	1.01	1.04
P(C,V)9*C20	FC/PC60C	1.00	1.00	1.03
P(C,V)9*C20	MC60D	1.00	1.00	1.03
P(C,V)9*C20	MC61D	1.01	1.01	1.04
P(C,V)9*D20	FC/MC/PC60D	1.00	1.00	1.03
P(C,V)9*D20	MC61D	1.01	1.01	1.04

COOLING PERFORMANCE DATA																
AIR CONDITIONER MODEL NO.		H3RE060S06														
INDOOR COIL MODEL NO.		MC61														
CONDENSER ENTERING AIR TEMPERATURE	ID CFM	1550					1800					2050				
	ID DB	80	80	75	80	80	80	80	75	80	80	80	80	75	80	80
	ID WB	57	62	62	67	72	57	62	62	67	72	57	62	62	67	72
65	T.C.	52.7	58.9	53.1	62.5	62.4	55.9	60.2	55.2	64.0	62.9	59.1	61.5	57.2	65.6	63.5
	S.C.	47.9	48.5	38.3	38.0	28.9	50.5	51.7	41.4	42.2	30.4	53.1	54.9	44.5	46.4	31.9
	K.W.	2.7	2.8	2.8	2.9	2.9	2.8	2.8	2.8	2.9	2.9	2.8	2.8	2.8	2.8	2.9
75	T.C.	52.0	56.8	51.6	59.9	60.5	54.9	58.2	53.4	61.5	61.3	57.9	59.6	55.3	63.1	62.1
	S.C.	46.8	47.3	37.7	37.6	28.4	49.3	50.3	40.7	41.4	30.0	51.7	53.4	43.7	45.2	31.7
	K.W.	3.2	3.2	3.2	3.3	3.3	3.2	3.2	3.2	3.3	3.3	3.2	3.2	3.2	3.3	3.3
85	T.C.	51.2	54.7	50.0	57.4	58.7	54.0	56.2	51.7	59.0	59.7	56.7	57.7	53.3	60.7	60.7
	S.C.	45.8	46.0	37.1	37.2	27.9	48.0	48.9	40.0	40.6	29.7	50.3	51.8	42.9	44.0	31.5
	K.W.	3.6	3.6	3.6	3.6	3.7	3.6	3.6	3.6	3.7	3.7	3.6	3.6	3.6	3.7	3.7
95	T.C.	50.5	52.6	48.4	54.9	56.9	53.0	54.2	49.9	56.6	58.1	55.5	55.8	51.4	58.2	59.4
	S.C.	44.7	44.8	36.4	36.8	27.4	46.8	47.5	39.2	39.8	29.3	48.8	50.3	42.0	42.8	31.2
	K.W.	4.0	4.0	4.0	4.0	4.1	4.0	4.0	4.0	4.1	4.1	4.0	4.1	4.0	4.1	4.1
105	T.C.	48.3	49.8	46.0	52.6	54.4	50.8	51.8	47.4	54.1	55.5	53.4	53.7	48.8	55.6	56.7
	S.C.	42.9	43.1	35.3	35.9	26.3	44.8	45.5	38.0	38.9	28.2	46.8	48.0	40.6	41.8	30.2
	K.W.	4.6	4.6	4.6	4.6	4.7	4.6	4.6	4.6	4.6	4.7	4.6	4.6	4.6	4.7	4.7
115	T.C.	46.1	47.1	43.7	50.4	52.0	48.7	49.4	45.0	51.7	53.0	51.3	51.7	46.3	53.1	54.1
	S.C.	41.1	41.5	34.2	35.1	25.3	43.0	43.6	36.7	38.0	27.2	44.8	45.7	39.3	40.8	29.1
	K.W.	5.1	5.2	5.2	5.2	5.2	5.1	5.2	5.2	5.2	5.3	5.2	5.2	5.2	5.2	5.3
125	T.C.	44.0	44.4	41.3	48.2	49.6	46.6	47.0	42.5	49.4	50.5	49.2	49.7	43.7	50.5	51.4
	S.C.	39.4	39.9	33.1	34.3	24.2	41.1	41.7	35.5	37.0	26.1	42.9	43.5	37.9	39.8	28.1
	K.W.	5.7	5.7	5.7	5.7	5.8	5.7	5.7	5.7	5.8	5.8	5.7	5.8	5.7	5.8	5.8

NOTE: ALL CAPACITIES INCLUDE INDOOR FAN HEAT AT 1250 BTUH/1000 CFM.

Multipliers for determining the performance with other indoor sections.

NOTE: For dry bulb temperatures different than those listed (between 73-87 F), sensible capacity increases by 1060 BTUH per 1000 CFM per degree above the listed temperature and decreases by 1060 BTUH per 1000 CFM per degree below the listed temperature.

Air Handler	Coil	T.C.	S.C.	KW
AHP/SHP60	-	1.00	1.06	1.00
AV/SV60	-	1.00	1.06	1.00
F*FV060	-	1.00	1.06	1.00
MA20D	FC/MC60D	1.00	1.04	1.00
MA20D	MC61D	1.01	1.05	1.01
MV20D	FC/MC60D	1.00	1.01	1.00
MV20D	MC61D	1.01	1.02	1.01
-	FC/MC/PC/UC60	1.00	1.04	1.00
-	HC60	1.00	1.04	1.00
-	HD60	1.00	1.04	1.00

Variable Speed Furnace	Coil	T.C.	S.C.	KW
PV8*C20	FC/PC60C	0.98	1.02	0.98
PV8*C20	HC60	0.98	1.02	0.98
PV8*C20	HD60	1.00	1.02	1.00
PV8*C20	MC61D	1.01	1.03	1.01
P(C,V)9*C20	FC/PC60C	0.99	0.99	0.99
P(C,V)9*C20	HD60	0.99	0.99	0.99
P(C,V)9*C20	MC61D	1.00	1.00	1.00
P(C,V)9*D20	FC/MC/PC60D	0.99	0.99	0.99
P(C,V)9*D20	HC60	0.99	0.99	0.99
P(C,V)9*D20	HD60	1.00	1.00	1.00
P(C,V)9*D20	MC61D	1.00	1.00	1.00