



## Heating and Air Conditioning

### TECHNICAL GUIDE

#### AFFINITY

#### SPLIT-SYSTEM AIR CONDITIONERS

13 SEER – R-22

#### MODELS:

CMB018 THRU 060

(1.5 THRU 5 NOMINAL TONS)



Due to continuous product improvement, specifications are subject to change without notice.

Visit us on the web at [www.york](http://www.york)

Additional rating information can be found at [www.ari.org/aridirectory](http://www.ari.org/aridirectory)

### DESCRIPTION

The CMB Series condensing unit is the outdoor part of a versatile air conditioning system. It is designed to be custom matched with one of our complete line of evaporator sections, each designed to serve a specific function. Matching air handlers are available for upflow, downflow, and horizontal left or right application to provide a complete system. Electric heaters are available if required. Add-on coils are available for use with upflow, downflow, or horizontal furnaces. Field installed accessories are available as needed.

### WARRANTY

5-year limited parts warranty.

10-year limited compressor warranty.

### FEATURES

- **Superior Coil Protection** – A stamped decorative metal coil guard completely protects coil from debris and other large damaging material while a polymer mesh further protects the coil against smaller particles.
- **Color Grilles** - Engineered around the needs and wants of the consumer, Affinity units are now available with a choice of color options designed to compliment any home.
- **Isolated Compressor Compartment** – A molded composite bulkhead isolates the compressor from the rest of the unit reducing sound and vibration.
- **Protected Compressors** – Each compressor is protected against abnormal pressures by an internal pressure relief valve and factory installed high and low pressure controls. Additional protection against moisture and debris is provided by factory installed liquid line filter driers.
- **Durable Finish** – Automotive quality finish provides the ultimate protection from harmful U.V. rays and rust creep ensuring long-lasting high quality appearance. A powder-paint topcoat is applied over a baked-on primer, using a galvanized, zinc coated steel base material. The result is a finish that has been proven in testing to provide 33% greater durability than conventional powder-coat finishes.
- **Lower Installed Cost** – Designed to provide enhanced installability by featuring a slide-down control compartment and angled service valves to reduce overall installation time and cost.
- **Low Operating Sound Levels** – A fan design boasting technology adapted from aeronautic and defense engineering provides for whisper quiet operation by allowing airflow to flow smoothly and efficiently across the fan tips.
- **Filter-Drier** – A factory installed, solid core liquid line filter-drier filters harmful debris and moisture from the system.
- **Easy Service Access** – A full end, full service, access panel with handle makes for easy entry to internal components.
- **Composite Base** - Strong and durable composite base pan resists rust and corrosion while it helps reduce vibrations and noise.
- **Quiet drive system** - Features combination of swept-wing fan, composite base pan, isolated compressor compartment and two-stage compressor to reduce overall sound to a mere whisper.
- **Low RPM fan motor** - Helps to reduce airflow noise.

Certified in accordance with the Unitary Small Equipment certification program, which is based on ARI Standard 210/240.

**Physical and Electrical Data**

MODEL		CMB01811	CMB02411	CMB03011	CMB03611	CMB04211	CMB04811	CMB06011
Unit Supply Voltage		208-230V, 1 $\phi$ , 60Hz						
Normal Voltage Range <sup>1</sup>		187 to 252						
Minimum Circuit Ampacity		8.9	14.3	15.1	18.3	25.5	30.3	32.7
Max. Overcurrent Device Amps <sup>2</sup>		15.0	20.0	25.0	30.0	40.0	50.0	50.0
Min. Overcurrent Device Amps <sup>3</sup>		10.0	15.0	15.0	20.0	30.0	30.0	35.0
Compressor Type		Recip	Recip	Recip	Recip	Scroll	Scroll	Scroll
Compressor Amps	Rated Load	6.7	10.2	10.9	13.4	19.2	23.0	25.0
	Locked Rotor	36.0	54.0	61.0	78.0	105.0	115.0	150.0
Crankcase Heater		No	No	No	No	No	No	No
Fan Motor Amps	Rated Load	0.50	0.50	1.5	1.5	1.5	1.5	1.5
Fan Diameter Inches		22	22	22	22	22	24	24
Fan Motor	Rated HP	1/15	1/15	1/4	1/4	1/4	1/4	1/4
	Nominal RPM	850	850	850	850	850	850	850
	Nominal CFM	1900	2000	3100	3300	3300	3650	3600
Coil	Face Area Sq. Ft.	14.86	14.86	17.15	17.15	20.58	23.58	23.58
	Rows Deep	1	1	1	1	1	1	2
	Fins / Inch	22	22	22	22	22	22	18
Liquid Line Set OD (Field Installed)		3/8	3/8	3/8	3/8	3/8	3/8	3/8
Vapor Line Set OD (Field Installed)		3/4	3/4	3/4	3/4	7/8	7/8	1-1/8
Unit Charge (Lbs. - Oz.) <sup>4</sup>		5 - 6	5 - 9	6 - 6	7 - 4	8 - 15	8 - 12	15 - 0
Charge Per Foot, Oz.		0.68	0.68	0.68	0.68	0.70	0.70	0.76
Operating Weight Lbs.		195	195	215	215	225	240	285

- 1 Rated in accordance with ARI Standard 110, utilization range "A".
- 2 Dual element fuses or HACR circuit breaker. Maximum allowable overcurrent protection.
- 3 Dual element fuses or HACR circuit breaker. Minimum recommended overcurrent protection.
- 4 The Unit Charge is correct for the outdoor unit, matched indoor coil and 15 feet of refrigerant tubing. For tubing lengths other than 15 feet, add or subtract the amount of refrigerant, using the difference in length multiplied by the per foot value.

All dimensions are in inches. They are subject to change without notice. Certified dimensions will be provided upon request.

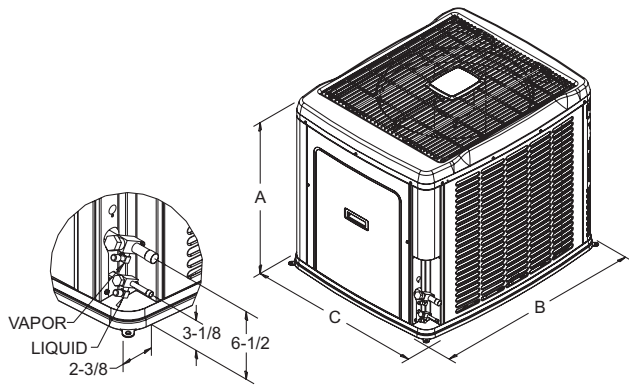

Unit Model	Dimensions (Inches)			Refrigerant Connection Service Valve Size	
	A	B	C	Liquid	Vapor
018	29-1/2	37	31	3/8"	3/4"
024	29-1/2	37	31		
030	33-1/2	37	31		
036	33-1/2	37	31		
042	39-1/2	37	31		7/8"
048	39-1/2	42	34		
060	39-1/2	42	34		7/8"*

\* Expander fitting required for 1-1/8" lineset.

Additional R-22 Charge / TXV Size for Various Matched Systems							
Outdoor Unit	CMB01811	CMB02411	CMB03011	CMB03611	CMB04211	CMB04811	CMB06011
Unit Orifice (s)	1TVM2A1	1TVM2A1	1TVM2A1	1TVM2C1	1TVM2C1	1TVM2C1	1TVM2C1
Factory R-22 Charge, lbs-oz	5 - 6	5 - 9	6 - 6	7 - 4	8 - 15	8 - 12	15 - 0
Indoor Coil <sup>1, 2</sup>	TXV Kit <sup>3</sup> - Additional Charge, Oz						
FC/MC/PC/UC18A2A	0	-	-	-	-	-	-
FC/MC/PC/UC18B2A	0	-	-	-	-	-	-
FC/MC/PC/UC24A2A	0	0	-	-	-	-	-
FC/MC/PC/UC24B2A	0	0	-	-	-	-	-
FC/MC/PC/UC30A2A	-	0	0	-	-	-	-
FC/MC/PC/UC30B2A	-	0	0	-	-	-	-
FC/MC/PC35B2A	-	-	-	0	-	-	-
FC/MC/PC35B2C	-	-	-	0	-	-	-
FC/MC/PC/UC36A2A	-	-	0	-	-	-	-
FC/MC/PC/UC36B2A	-	-	0	-	-	-	-
FC/MC/PC/UC36C2A	-	-	0	-	-	-	-
FC/MC/PC/UC42B2C	-	-	-	0	-	-	-
FC/MC/PC/UC42C2C	-	-	-	0	-	-	-
FC/MC/PC/UC48C2C	-	-	-	0	0	0	-
FC/MC/PC/UC48D2C	-	-	-	0	0	0	-
FC/PC/UC60C2C	-	-	-	-	-	-	0
FC/MC/PC/UC60D2C	-	-	-	-	-	-	0
MC61D2C	-	-	-	-	-	-	0
HC18A2A	0	-	-	-	-	-	-
HC30A2A	-	0	0	-	-	-	-
HC36B2A	-	-	0	-	-	-	-
HC42C2C	-	-	-	0	0	-	-
HC60D2C	-	-	-	-	-	-	0
HD24A2A	0	0	-	-	-	-	-
HD36B2A	-	-	-	-	-	-	-
HD48C2C	-	-	-	0	0	0	-
HD60D2C	-	-	-	-	-	-	0
AHP18B2A	0	-	-	-	-	-	-
AHP24B2A	0	0	-	-	-	-	-
AHP30B2A	-	0	0	-	-	-	-
AHP36C2A	-	-	0	0	-	-	-
AHP42C2C	-	-	-	0	-	-	-
AHP/SHP48D2C	-	-	-	-	0	0	-
AHP/SHP60D2C	-	-	-	0	0	0	0
AV24B2A	0	0	-	-	-	-	-
AV36C2A	-	-	0	0	-	-	-
AV/SV48D2C	-	-	-	-	0	0	-
AV/SV60D2C	-	-	-	-	0	0	0
FC/MC/PC/UC18A3X	0	-	-	-	-	-	-
FC/MC/PC/UC18B3X	0	-	-	-	-	-	-
FC/MC/PC/UC24A3X	0	0	-	-	-	-	-
FC/MC/PC/UC24B3X	0	0	-	-	-	-	-
FC/MC/PC/UC30A3X	-	0	0	-	-	-	-
FC/MC/PC/UC30B3X	-	0	0	-	-	-	-
FC/MC/PC/35B3X	-	-	-	0	-	-	-
FC/MC/PC35C3X	-	-	-	0	-	-	-
FC/MC/PC/UC36A3X	-	-	0	-	-	-	-
FC/MC/PC/UC36B3X	-	-	0	-	-	-	-
FC/MC/PC/UC36C3X	-	-	0	-	-	-	-
FC/MC/PC/UC42B3X	-	-	-	0	-	-	-
FC/MC/PC/UC42C3X	-	-	-	0	-	-	-
FC/MC/PC/UC48C3X	-	-	-	0	0	0	-
FC/MC/PC/UC48D3X	-	-	-	0	0	0	-
FC/PC/UC60C3X	-	-	-	-	-	-	0
FC/MC/PC/UC60D3X	-	-	-	-	-	-	0
MC61D3X	-	-	-	-	-	-	0

For Notes See Page 4.

Additional R-22 Charge / TXV Size for Various Matched Systems							
Outdoor Unit	CMB01811	CMB02411	CMB03011	CMB03611	CMB04211	CMB04811	CMB06011
Unit Orifice (s)	1TVM2A1	1TVM2A1	1TVM2A1	1TVM2C1	1TVM2C1	1TVM2C1	1TVM2C1
Factory R-22 Charge, lbs-oz	5 - 6	5 - 9	6 - 6	7 - 4	8 - 15	8 - 12	15 - 0
Indoor Coil <sup>1,2</sup>	TXV Kit <sup>3</sup> - Additional Charge, Oz						
HC18A3X	0	-	-	-	-	-	-
HC30A3X	-	0	0	-	-	-	-
HC36B3X	-	-	0	-	-	-	-
HC42C3X	-	-	-	0	0	-	-
HC60D3X	-	-	-	-	-	-	0
HD24A3X	0	0	-	-	-	-	-
HD36B3X	-	-	0	-	-	0	-
HD48C3X	-	-	-	0	0	0	-
HD60D3X	-	-	-	-	-	-	0
AHP18B3X	0	-	-	-	-	-	-
AHP24B3X	0	0	-	-	-	-	-
AHP30B3X	-	0	0	-	-	-	-
AHP36C3X	-	-	0	0	-	-	-
AHP42C3X	-	-	-	0	-	-	-
AHP/SHP48D3X	-	-	-	-	0	0	-
AHP/SHP60D3X	-	-	-	0	0	0	0
AV24B3X	0	0	-	-	-	-	-
AV36C3X	-	-	0	0	-	-	-
AV/SV48D3X	-	-	-	-	0	0	-
AV/SV60D3X	-	-	-	-	0	0	0
F*FP024	0	-	-	-	-	-	-
F*FP036	-	-	0	-	-	-	-
F*FV060	-	-	-	-	0	0	0

**FOOTNOTES:**

- 1 Systems matched with furnace or air handlers not equipped with blower-off delays may require blower Time Delay Kit 2FD06700224.
  - 2 PC coils cannot be used in downflow or horizontal applications. FC coils cannot be used in horizontal applications.
  - 3 A TXV kit must be used with these coils to obtain system performance (2A, 2B, and 2C indicate 1TVM series).
- \* This loose coil match does not achieve 13 SEER.

**PROCEDURES:**

1. Unit factory charge listed on the unit nameplate includes refrigerant for the condenser, the smallest evaporator and 15 feet of interconnecting line tubing.
2. Verify the TXV and additional charge required for specific evaporator coil in the system using the above table.
3. Additional charge for the amount of interconnecting line tubing greater than 15 feet at the rate specified in the Physical and Electrical Data Table.
4. Permanently mark the unit nameplate with the total system charge. Total System Charge = Base Charge (as shipped) + adder for evaporator + adder for line set.

**COOLING CAPACITY - With Air Handler Coils**

UNIT MODEL	AIR HANDLER		COIL <sup>1</sup> MODEL	COOLING				
	MODEL	W		RATED CFM	NET MBH		SEER	EER
					TOTAL	SENSIBLE		
<b>1 PH 13 SEER AC MA</b>								
CMB01811	MA08B	17	FC/MC18B	600	18.0	12.1	13.00	11.00
	MA12B	17	FC/MC18B	600	18.0	12.1	13.00	11.00
	MA08B	17	FC/MC24B	600	18.2	12.3	13.00	11.00
	MA12B	17	FC/MC24B	600	18.2	12.3	13.00	11.00
CMB02411	MA08B	17	FC/MC24B	800	23.0	16.8	13.00	11.00
	MA12B	17	FC/MC24B	800	23.0	16.8	13.00	11.00
	MA08B	17	FC/MC30B	800	23.0	16.8	13.00	11.00
	MA12B	17	FC/MC30B	800	23.0	16.8	13.00	11.00
CMB03011	MA12B	17	FC/MC30B	1000	29.6	20.7	13.00	11.00
	MA12B	17	FC/MC36B	1000	29.6	20.9	13.00	11.00
CMB03611	MA12B	17	FC/MC35B	1200	35.4	26.6	13.00	11.00
	MA16C	21	FC/MC35C	1200	35.4	26.6	13.00	11.00
	MA12B	17	FC/MC42B	1200	35.4	26.6	13.00	11.00
	MA16C	21	FC/MC42C	1200	35.4	26.6	13.00	11.00
	MA14D	24	FC/MC48D	1200	36.0	27.1	13.00	11.00
CMB04211	MA16C	21	FC/MC48C	1400	41.5	30.7	13.00	11.00
CMB04811	MA16C	21	FC/MC48C	1600	47.5	34.2	13.00	11.00
	MA20D	24	FC/MC48D	1600	47.5	34.2	13.00	11.00
CMB06011	MA20D	24	FC/MC60D	1800	55.5	40.0	13.00	11.00
	MA20D	24	MC61D	1800	56.0	40.4	13.00	11.00
<b>1 PH 13 SEER AC WITH MV - VARIABLE SPEED</b>								
CMB01811	MV12B	17	FC/MC18B	600	18.3	12.0	14.00	11.50
	MV12B	17	FC/MC24B	600	18.6	12.2	14.00	11.50
CMB02411	MV12B	17	FC/MC24B	800	23.4	16.8	14.00	11.50
	MV12B	17	FC/MC30B	800	23.4	16.8	14.00	11.50
CMB03011	MV12B	17	FC/MC30B	1000	30.0	20.6	14.00	11.50
	MV12B	17	FC/MC36B	1000	30.0	20.6	14.00	11.50
	MV16C	21	FC/MC36C	1000	30.0	20.7	14.00	11.50
CMB03611	MV12B	17	FC/MC35B	1200	35.6	26.2	13.75	11.00
	MV16C	21	FC/MC35C	1200	35.8	26.4	14.00	11.50
	MV12B	17	FC/MC42B	1200	35.6	26.2	13.75	11.00
	MV16C	21	FC/MC42C	1200	35.8	26.4	14.00	11.50
	MV16C	21	FC/MC48C	1200	36.4	26.9	14.00	11.50
	MV20D	24	FC/MC48D	1200	36.4	26.9	14.00	11.50
CMB04211	MV16C	21	FC/MC48C	1400	41.0	30.2	13.75	11.00
	MV20D	24	FC/MC48D	1400	41.0	30.3	14.00	11.50
CMB04811	MV16C	21	FC/MC48C	1600	47.5	33.6	13.50	11.00
	MV20D	24	FC/MC48D	1600	47.5	33.5	13.50	11.00
CMB06011	MV20D	24	FC/MC60D	1800	55.5	39.1	13.00	11.00
	MV20D	24	MC61D	1800	55.0	39.4	13.25	11.00

For Notes See Page 6.

**COOLING CAPACITY - With Air Handler Coils (Continued)**

UNIT MODEL	AIR HANDLER		COIL <sup>1</sup> MODEL	COOLING				
	MODEL	W		RATED CFM	NET MBH		SEER	EER
					TOTAL	SENSIBLE		
<b>1 PH 13 SEER AC WITH AHP / F*FP / F*FV</b>								
CMB01811	AHP18	17	—	650	18.0	12.6	13.00	11.00
	AHP24	17	—	655	18.2	12.8	13.25	11.00
	F*FP024	17	—	650	18.0	12.6	13.00	11.00
CMB02411	AHP24	17	—	830	23.0	17.1	13.00	11.00
	AHP30	17	—	795	23.6	17.2	13.25	11.00
CMB03011	AHP30	17	—	1015	30.6	21.7	13.00	11.00
	AHP36	21	—	1040	31.0	22.2	13.25	11.00
CMB03611	AHP36	21	—	1235	36.0	27.9	13.00	11.00
	AHP42	21	—	1255	36.0	27.9	13.25	11.00
	AHP/SHP60	24	—	1255	36.0	27.9	14.00	11.50
CMB04211	AHP/SHP48	24	—	1400	42.0	31.4	13.00	11.00
	AHP/SHP60	24	—	1400	42.0	31.6	14.00	11.50
CMB04811	AHP/SHP48	24	—	1675	48.0	35.1	13.00	11.00
	AH/SHP60	24	—	1600	48.0	35.1	13.50	11.00
	F*FV060	24	—	1600	48.0	35.1	13.50	11.00
CMB06011	AHP/SHP60	24	—	1850	55.5	40.5	13.00	11.00
	F*FV060	24	—	1850	55.5	40.5	13.00	11.00
<b>1 PH 13 SEER AC WITH AV - VARIABLE SPEED</b>								
CMB01811	AV24	17	—	600	18.0	12.6	14.00	11.50
CMB02411	AV24	17	—	800	23.4	17.3	14.00	11.50
CMB03011	AV36	21	—	1000	30.0	21.7	14.00	11.50
CMB03611	AV/SV48	24	—	1200	36.0	27.9	13.50	11.00
CMB04211	AV/SV48	24	—	1400	42.0	31.6	14.00	11.50
CMB04811	AV/SV48	24	—	1600	47.5	34.7	13.75	11.00
CMB06011	AV/SV60	24	—	1800	55.0	40.1	13.25	11.00
<p>Rated in accordance with DOE test procedures (Federal Register 12-27-79 and 3-18-88) and ARI Standards 210.  Cooling MBH based on 80°F entering air temperature, 50% RH, and rated air flow.  EER (Energy Efficiency Ratio) is the total cooling output in electric power in watt-hours at those conditions.  SEER (Seasonal Energy Efficiency Ratio) is the total cooling output in BTU's during a normal annual usage period for cooling divided by the total electric power input in watt-hours during the same period.</p>								

<sup>1</sup> MC coils available with a factory installed horizontal drain pan. See price pages for specific model number.

— = Not applicable.

Go to [www.ari.org/aridirectory](http://www.ari.org/aridirectory) for the latest additional matches.

**COOLING CAPACITY - Upflow, Downflow & Horizontal Furnaces and Coils**

UNIT MODEL	FURNACE**		COIL MODEL	RATED CFM	COOLING		SEER <sup>1</sup>	EER
	CFM RANGE (Min.-max.)	W			NET MBH			
					TOTAL	SENSIBLE		
CMB01811	450 750	14,17	FC/MC/PC/UC18	600	18.0	12.1	13.00	11.00
		14,17	FC/MC/PC/UC24	600	18.0	12.3	13.00	11.00
		14	HC18	600	18.0	12.1	13.00	11.00
		–	HD24	600	18.0	12.5	13.00	11.00
CMB02411	600 1000	14,17	FC/MC/PC/UC24	800	23.0	16.8	13.00	11.00
		14,17	FC/MC/PC/UC30	800	23.0	16.8	13.00	11.00
		14	HC30	800	23.4	17.1	13.00	11.00
		–	HD24	800	23.4	17.3	13.00	11.00
CMB03011	800 1200	14,17	FC/MC/PC/UC30	1000	29.6	20.7	13.00	11.00
		14,17,21	FC/MC/PC/UC36	1000	29.6	20.9	13.00	11.00
		14	HC30	1000	29.6	21.3	13.00	11.00
		17	HC36	1000	30.0	21.5	13.00	11.00
		–	HD36	1000	30.0	21.5	13.00	11.00
CMB03611	1000 1400		FC/MC/PC/UC35	1200	35.4	26.6	13.00	11.00
		17,21	FC/MC/PC/UC42	1200	35.4	26.6	13.00	11.00
		21,24	FC/MC/PC/UC48	1200	36.0	27.1	13.00	11.00
		21	HC42	1200	36.0	27.0	13.00	11.00
		–	HD48	1140	36.0	26.6	13.00	11.00
CMB04211	1200 1600	21,24	FC/MC/PC/UC48	1400	41.5	30.7	13.00	11.00
		21	HC42	1400	41.0	30.6	13.00	11.00
		–	HD48	1330	41.5	30.4	13.00	11.00
CMB04811	1400 1800	21,24	FC/MC/PC/UC48	1600	47.5	34.2	13.00	11.00
		21	HC42	1600	47.0	33.9	13.00	11.00
		–	HD48	1520	48.0	33.9	13.00	11.00
CMB06011	1600 2000	21,24	FC/MC/PC/UC60	1800	55.5	40.0	13.00	11.00
		24	FC/MC/PC/UC61	1800	56.0	40.4	13.00	11.00
		24	HC60	1800	55.5	40.0	13.00	11.00
		–	HD60	1800	55.0	40.3	13.00	11.00

<sup>1</sup> Requires a 2FD06700224 Blower Time Delay unless a standard furnace is equipped with one.

\*\* Refer to Quick Selection Chart for specific furnace match-up.

**COOLING CAPACITY - With Variable Speed Furnaces**

UNIT MODEL	VARIABLE SPEED FURNACE MODEL	COIL MODEL <sup>1</sup>	W	COOLING				
				RATED CFM	NET MBH		SEER	EER
					TOTAL	SENSIBLE		
<b>1 PH 13 SEER AC WITH PV8 / PV9 - VARIABLE SPEED<sup>2</sup></b>								
CMB01811	PV8*A12	FC/MC/PC18A	14	600	18.0	12.2	14.00	11.50
	PV8*B16	FC/MC/PC18B	17	600	18.0	12.2	14.00	11.50
	PV9*A12	FC/MC/PC18A	14	600	18.0	12.2	14.00	11.50
	P(C,V)9*B12	FC/MC/PC18B	17	600	18.0	12.2	14.00	11.50
	PV8*A12	FC/MC/PC24A	14	600	18.0	12.4	14.00	11.50
	PV8*B16	FC/MC/PC24B	17	600	18.0	12.4	14.00	11.50
	PV9*A12	FC/MC/PC24A	14	600	18.0	12.4	14.00	11.50
	P(C,V)9*B12	FC/MC/PC24B	17	600	18.0	12.4	14.00	11.50
	PV8*A12	HC18	14	600	18.0	12.2	14.00	11.50
	PV9*A12	HC18	14	600	18.0	12.2	14.00	11.50
CMB02411	PV8*A12	FC/MC/PC24A	14	800	23.2	16.9	14.00	11.50
	PV8*B16	FC/MC/PC24B	17	800	23.4	16.9	14.00	11.50
	PV9*A12	FC/MC/PC24A	14	800	23.2	16.9	14.00	11.50
	P(C,V)9*B12	FC/MC/PC24B	17	800	23.2	16.9	14.00	11.50
	PV8*A12	FC/MC/PC30A	14	800	23.2	16.9	14.00	11.50
	PV8*B16	FC/MC/PC30B	17	800	23.4	16.9	14.00	11.50
	PV9*A12	FC/MC/PC30A	14	800	23.2	16.9	14.00	11.50
	P(C,V)9*B12	FC/MC/PC30B	17	800	23.2	16.9	14.00	11.50
	PV8*A12	HC30	14	800	23.6	17.2	14.00	11.50
	PV9*A12	HC30	14	800	23.6	17.2	14.00	11.50
CMB03011	PV8*A12	FC/MC/PC30A	14	1000	30.0	20.9	13.75	11.00
	PV8*B16	FC/MC/PC30B	17	1000	30.0	21.0	14.00	11.50
	PV9*A12	FC/MC/PC30A	14	1000	29.8	20.9	13.50	11.00
	P(C,V)9*B12	FC/MC/PC30B	17	1000	30.0	20.9	13.75	11.00
	PV8*A12	FC/MC/PC36A	14	1000	30.0	21.0	13.75	11.00
	PV8*B16	FC/MC/PC36B	17	1000	30.0	21.0	14.00	11.50
	PV8*C16	FC/MC/PC36C	21	1000	30.0	21.0	14.00	11.50
	PV8*C20	FC/MC/PC36C	21	1000	30.0	21.0	14.00	11.50
	PV9*A12	FC/MC/PC36A	14	1000	30.0	21.0	13.75	11.00
	P(C,V)9*B12	FC/MC/PC36B	17	1000	30.0	21.0	14.00	11.50
	P(C,V)9*C16	FC/MC/PC36C	21	1000	30.0	21.0	14.00	11.50
	P(C,V)9*C20	FC/MC/PC36C	21	1000	30.0	21.0	14.00	11.50
	PV8*A12	HC30	14	1000	30.0	21.0	14.00	11.50
	PV9*A12	HC30	14	1000	30.0	21.0	14.00	11.50
	PV8*B16	HC36	17	1000	30.0	21.0	14.00	11.50
	P(C,V)9*B12	HC36	17	1000	30.0	21.0	14.00	11.50
	PV8*A12	HD36	-	1000	30.0	21.0	14.00	11.50
	PV8*B16	HD36	-	1000	30.0	21.0	14.00	11.50
	PV8*C16	HD36	-	1000	30.0	21.0	14.00	11.50
	PV8*C20	HD36	-	1000	30.0	21.0	14.00	11.50
CMB03611	PV8*B16	FC/MC/PC35B	17	1200	35.8	26.8	13.75	11.00
	PV8*C16	FC/MC/PC35C	21	1200	36.0	26.8	14.00	11.50
	PV8*C20	FC/MC/PC35C	21	1200	36.0	26.8	14.00	11.50
	P(C,V)9*B12	FC/MC/PC35B	17	1200	35.6	26.7	13.50	11.00
	P(C,V)9*C16	FC/MC/PC35C	21	1200	35.8	26.8	13.75	11.00
	P(C,V)9*C20	FC/MC/PC35C	21	1200	35.8	26.8	13.75	11.00

For Notes see Page 9.

## COOLING CAPACITY - With Variable Speed Furnaces

UNIT MODEL	VARIABLE SPEED FURNACE MODEL	COIL MODEL <sup>1</sup>	W	COOLING				
				RATED CFM	NET MBH		SEER	EER
					TOTAL	SENSIBLE		
<b>1 PH 13 SEER AC WITH PV8 / PV9 - VARIABLE SPEED<sup>2</sup></b>								
CMB03611	PV8*B16	FC/MC/PC42B	17	1200	35.8	26.8	13.75	11.00
	PV8*C16	FC/MC/PC42C	21	1200	36.0	26.8	14.00	11.50
	PV8*C20	FC/MC/PC42C	21	1200	36.0	26.8	14.00	11.50
	P(C,V)9*B12	FC/MC/PC42B	17	1200	35.6	26.7	13.50	11.00
	P(C,V)9*C16	FC/MC/PC42C	21	1200	35.8	26.8	13.75	11.00
	P(C,V)9*C20	FC/MC/PC42C	21	1200	35.8	26.8	13.75	11.00
	PV8*C16	FC/MC/PC48C	21	1200	36.0	27.4	14.00	11.50
	PV8*C20	FC/MC/PC48C	21	1200	36.0	27.4	14.00	11.50
	P(C,V)9*C16	FC/MC/PC48C	21	1200	36.0	27.4	14.00	11.50
	P(C,V)9*C20	FC/MC/PC48C	21	1200	36.0	27.4	14.00	11.50
	P(C,V)9*D20	FC/MC/PC48D	24	1200	36.0	27.4	14.00	11.50
	PV8*C16	HC42	21	1200	36.0	27.2	14.00	11.50
	PV8*C20	HC42	21	1200	36.0	27.2	14.00	11.50
	P(C,V)9*C16	HC42	21	1200	36.0	27.2	14.00	11.50
	P(C,V)9*C20	HC42	21	1200	36.0	27.2	14.00	11.50
	PV8*C16	HD48	—	1200	36.0	27.4	14.00	11.50
	PV8*C20	HD48	—	1200	36.0	27.4	14.00	11.50
	P(C,V)9*C16	HD48	—	1200	36.0	27.4	14.00	11.50
P(C,V)9*C20	HD48	—	1200	36.0	27.4	14.00	11.50	
P(C,V)9*D20	HD48	—	1200	36.0	27.4	14.00	11.50	
CMB04211	PV8*C16	FC/MC/PC48C	21	1400	41.5	30.8	13.50	11.00
	PV8*C20	FC/MC/PC48C	21	1400	41.0	30.9	13.50	11.00
	P(C,V)9*C16	FC/MC/PC48C	21	1400	41.5	30.8	13.25	11.00
	P(C,V)9*C20	FC/MC/PC48C	21	1400	41.5	30.8	13.50	11.00
	P(C,V)9*D20	FC/MC/PC48D	24	1400	41.5	30.8	13.50	11.00
	PV8*C16	HC42	21	1400	41.5	30.8	13.25	11.00
	PV8*C20	HC42	21	1400	41.5	30.7	13.50	11.00
	P(C,V)9*C16	HC42	21	1400	41.5	30.8	13.25	11.00
	P(C,V)9*C20	HC42	21	1400	41.5	30.9	13.50	11.00
	PV8*C16	HD48	—	1400	42.0	31.2	13.75	11.00
	PV8*C20	HD48	—	1400	42.0	31.2	13.75	11.00
	P(C,V)9*C16	HD48	—	1400	42.0	31.2	13.50	11.00
	P(C,V)9*C20	HD48	—	1400	42.0	31.2	13.75	11.00
	P(C,V)9*D20	HD48	—	1400	42.0	31.2	13.50	11.00
CMB04811	PV8*C16	FC/MC/PC48C	21	1500	47.0	33.2	13.05	11.00
	PV8*C20	FC/MC/PC48C	21	1600	47.0	34.3	13.05	11.00
	P(C,V)9*C16	FC/MC/PC48C	21	1600	47.0	34.2	13.05	11.00
	P(C,V)9*C20	FC/MC/PC48C	21	1600	47.0	34.2	13.05	11.00
	P(C,V)9*D20	FC/MC/PC48D	24	1600	47.0	34.3	13.05	11.00
	PV8*C16	HC42	21	1500	46.5	33.0	13.05	11.00
	PV8*C20	HC42	21	1600	47.0	34.0	13.05	11.00
	P(C,V)9*C16	HC42	21	1600	46.5	33.9	13.05	11.00
	P(C,V)9*C20	HC42	21	1600	46.5	33.9	13.05	11.00
	PV8*C16	HD48	—	1500	47.5	33.7	13.25	11.00
	PV8*C20	HD48	—	1600	48.0	34.9	13.25	11.00
	P(C,V)9*C16	HD48	—	1600	48.0	34.8	13.05	11.00
	P(C,V)9*C20	HD48	—	1600	48.0	34.8	13.25	11.00
	P(C,V)9*D20	HD48	—	1600	48.0	34.9	13.25	11.00
CMB06011	PV8*C20	FC/PC60C	21	1730	55.5	39.2	13.05	11.00
	P(C,V)9*C20	FC/PC60C	21	1620	55.0	38.2	13.05	11.00
	P(C,V)9*D20	FC/MC/PC60D	24	1620	55.0	38.2	13.25	11.00
	PV8*C20	MC61D	24	1730	55.5	39.6	13.05	11.00
	P(C,V)9*C20	MC61D	24	1620	55.0	38.3	13.05	11.00
	P(C,V)9*D20	MC61D	24	1620	55.5	38.4	13.25	11.00
	PV8*C20	HC60	24	1730	55.5	39.2	13.05	11.00
	P(C,V)9*D20	HC60	24	1620	55.0	38.2	13.25	11.00
	PV8*C20	HD60	—	1730	55.5	39.5	13.05	11.00
	P(C,V)9*C20	HD60	—	1620	55.0	38.3	13.05	11.00
P(C,V)9*D20	HD60	—	1620	55.5	38.4	13.25	11.00	

1 MC coils available with a factory installed horizontal drain pan. See price pages for specific model number.

2 Variable speed furnaces have B.O.D (Blower on Delay) standard.

**ACCESSORIES\***

**Hard Start Kit** - Provides increased starting torque for areas with low voltage.

**TXV Kits** - 1TVM2\* series thermal expansion valves precisely meter refrigerant for optimum performance

**Low Ambient Pressure Switch Kit (2LA06700224)**- Allows use of air conditioning at low outdoor ambient temperatures. For use with models containing R-22 refrigerant only.

**Dehumidistat (2HU16700124)** - Provides increased dehumidification when matched with variable speed furnace or air handler.

**Room Thermostats** - A wide selection of compatible thermostats are available to provide optimum performance and features for any installation.

1 Heat Stage only, manual, mechanical thermostat. Add sub-base for 1H/1C.

1H/1C, manual changeover electronic non-programmable thermostat.

1H/1C, auto/manual changeover, electronic programmable, deluxe 7-day, thermostat.

1H/1C, auto/manual changeover, electronic programmable.

\* For the most current accessory information, refer to the price book or consult factory.

**SOUND POWER RATINGS\***

UNIT MODEL	(dBA)
018	69
024	71
030	72
036	72
042	72
048	73
060	73

\* Rated in accordance with ARI 270-95 Standards.

**COLOR GRILLES**

CHOICE OF SEVERAL COLOR COIL GRILLES TO COMPLIMENT ANY HOME.		
Color Grill	Color Description	
1CP0126	Terra Cotta	018, 024
1CP0130		030, 036
1CP0136		042
1CP1136		048, 060
1CP0226	Jet Black	018, 024
1CP0230		030, 036
1CP0236		042
1CP1236		048, 060
1CP0326	Stone	018, 024
1CP0330		030, 036
1CP0336		042
1CP1336		048, 060
1CP0426	Bermuda	018, 024
1CP0430		030, 036
1CP0436		042
1CP1436		048, 060
1CP0526	Gunmetal	018, 024
1CP0530		030, 036
1CP0536		042
1CP1536		048, 060
1CP0626	Chocolate	018, 024
1CP0630		030, 036
1CP0636		042
1CP1636		048, 060

COOLING PERFORMANCE DATA																
OUTDOOR UNIT MODEL NO.		CMB01811														
INDOOR COIL MODEL NO.		FC/MC/PC/UC18														
CONDENSER ENTERING AIR TEMPERATURE	ID CFM	450					600					750				
	ID DB (°F)	80	80	75	80	80	80	80	75	80	80	80	80	75	80	80
	ID WB (°F)	57	62	62	67	72	57	62	62	67	72	57	62	62	67	72
65	T.C.	16.4	19.6	19.1	21.8	23.9	18.8	20.7	20.2	22.5	24.6	21.2	21.8	21.2	23.2	25.4
	S.C.	15.5	13.9	12.1	12.4	10.4	17.8	16.5	13.9	14.0	11.4	20.2	19.1	15.6	15.6	12.5
	K.W.	1.3	1.3	1.3	1.3	1.3	1.3	1.3	1.3	1.3	1.3	1.3	1.3	1.3	1.3	1.3
75	T.C.	15.6	18.3	17.9	20.3	22.4	17.7	19.3	18.8	21.0	23.1	19.8	20.3	19.8	21.7	23.9
	S.C.	14.8	13.3	11.5	11.8	9.8	16.8	15.8	13.2	13.3	10.8	18.8	18.2	14.9	14.9	11.9
	K.W.	1.3	1.4	1.4	1.4	1.4	1.4	1.4	1.4	1.4	1.4	1.4	1.4	1.4	1.4	1.4
85	T.C.	14.9	17.0	16.6	18.9	20.9	16.6	17.9	17.5	19.5	21.6	18.4	18.8	18.3	20.1	22.3
	S.C.	14.2	12.8	10.9	11.1	9.2	15.8	15.1	12.5	12.7	10.2	17.5	17.3	14.1	14.2	11.3
	K.W.	1.4	1.5	1.5	1.5	1.5	1.5	1.5	1.5	1.5	1.5	1.5	1.5	1.5	1.5	1.6
95	T.C.	14.1	15.8	15.4	17.4	19.4	15.6	16.5	16.1	18.0	20.1	17.0	17.3	16.8	18.6	20.8
	S.C.	13.5	12.3	10.4	10.5	8.6	14.8	14.4	11.9	12.0	9.7	16.1	16.4	13.4	13.5	10.7
	K.W.	1.5	1.6	1.6	1.6	1.6	1.6	1.6	1.6	1.6	1.7	1.6	1.6	1.6	1.7	1.7
105	T.C.	13.1	14.6	14.3	16.1	18.0	14.4	15.3	14.9	16.6	18.5	15.7	16.0	15.5	17.0	19.0
	S.C.	12.5	11.8	9.9	10.0	8.1	13.7	13.5	11.4	11.5	9.1	14.9	15.2	12.9	12.9	10.0
	K.W.	1.6	1.7	1.7	1.7	1.8	1.7	1.7	1.7	1.7	1.8	1.7	1.7	1.7	1.8	1.8
115	T.C.	12.1	13.5	13.2	14.9	16.6	13.3	14.1	13.7	15.2	16.9	14.4	14.7	14.1	15.5	17.2
	S.C.	11.6	11.4	9.5	9.6	7.6	12.7	12.7	10.9	10.9	8.5	13.7	14.0	12.4	12.3	9.4
	K.W.	1.7	1.7	1.7	1.8	1.9	1.8	1.8	1.8	1.8	1.9	1.8	1.8	1.8	1.9	1.9
125	T.C.	11.2	12.4	12.1	13.7	15.2	12.1	12.9	12.5	13.8	15.3	13.1	13.5	12.8	13.9	15.4
	S.C.	10.7	11.0	9.0	9.1	7.1	11.6	11.9	10.5	10.4	8.0	12.5	12.9	11.9	11.7	8.8
	K.W.	1.8	1.8	1.8	1.9	2.0	1.9	1.9	1.9	1.9	2.0	1.9	1.9	1.9	2.0	2.0

NOTE: ALL CAPACITIES ARE NET (KBTUH) WITH INDOOR FAN HEAT ALREADY DEDUCTED AT 1250 BTUH/1000 CFM.

### Multipliers for determining the performance with other indoor sections.

NOTE: For dry bulb temperatures different than those listed (between 73-87 F), sensible capacity increases by 1060 BTUH per 1000 CFM per degree above the listed temperature and decreases by 1060 BTUH per 1000 CFM per degree below the listed temperature.

Air Handler	Coil	T.C.	S.C.	KW
AHP18	–	1.00	1.04	1.00
AHP24	–	1.01	1.06	1.01
AV24	–	1.00	1.04	0.96
F*FP024	–	1.00	1.04	1.00
MA08B	FC/MC18B	1.00	1.00	1.00
MA08B	FC/MC24B	1.01	1.02	1.01
MA12B	FC/MC18B	1.00	1.00	1.00
MA12B	FC/MC24B	1.01	1.02	1.01
MV12B	FC/MC18B	1.02	0.99	0.97
MV12B	FC/MC24B	1.03	1.01	0.99
–	FC/MC/PC/UC18	1.00	1.00	1.00
–	FC/MC/PC/UC24	1.01	1.02	1.01
–	HC18	1.00	1.00	1.00

Variable Speed Furnace	Coil	T.C.	S.C.	KW
PV8*A12	FC/MC/PC18A	1.02	1.01	0.98
PV8*B16	FC/MC/PC18B	1.02	1.01	0.98
PV9*A12	FC/MC/PC18A	1.02	1.01	0.97
P(C,V)9*B12	FC/MC/PC18B	1.02	1.01	0.97
PV8*A12	FC/MC/PC24A	1.03	1.02	0.99
PV8*B16	FC/MC/PC24B	1.03	1.02	0.99
PV9*A12	FC/MC/PC24A	1.03	1.02	0.99
P(C,V)9*B12	FC/MC/PC24B	1.03	1.02	0.99
PV8*A12	HC18	1.02	1.01	0.98
PV9*A12	HC18	1.02	1.01	0.97
PV8*A12	HD24	1.06	1.05	1.01
PV9*A12	HD24	1.05	1.04	1.00

<b>COOLING PERFORMANCE DATA</b>																
<b>OUTDOOR UNIT MODEL NO.</b>		<b>CMB02411</b>														
<b>INDOOR COIL MODEL NO.</b>		<b>FC/MC/PC/UC24</b>														
<b>CONDENSER ENTERING AIR TEMPERATURE</b>	ID CFM	600					800					1000				
	ID DB (°F)	80	80	75	80	80	80	80	75	80	80	80	80	75	80	80
	ID WB (°F)	57	62	62	67	72	57	62	62	67	72	57	62	62	67	72
65	T.C.	21.9	24.4	22.1	26.4	28.8	23.8	25.6	24.1	27.1	30.6	25.7	26.7	26.2	27.7	32.5
	S.C.	21.1	18.9	15.9	15.9	13.2	23.1	22.2	18.1	18.3	14.8	25.0	25.5	20.3	20.6	16.3
	K.W.	1.5	1.6	1.6	1.6	1.6	1.6	1.6	1.6	1.6	1.6	1.6	1.6	1.6	1.6	1.7
75	T.C.	21.1	23.1	21.5	24.9	27.0	22.9	24.2	23.1	25.7	28.6	24.7	25.4	24.7	26.5	30.1
	S.C.	20.4	18.5	15.5	15.4	12.6	22.3	21.2	17.7	17.7	14.1	24.1	23.9	19.9	20.0	15.6
	K.W.	1.7	1.7	1.7	1.7	1.8	1.7	1.7	1.7	1.8	1.8	1.7	1.7	1.7	1.8	1.8
85	T.C.	20.3	21.8	21.0	23.3	25.3	22.1	22.9	22.1	24.4	26.5	23.8	24.0	23.2	25.4	27.8
	S.C.	19.6	18.0	15.1	15.0	12.1	21.4	20.1	17.3	17.2	13.5	23.2	22.2	19.4	19.5	14.9
	K.W.	1.8	1.8	1.8	1.9	1.9	1.9	1.9	1.8	1.9	1.9	1.9	1.9	1.9	2.0	2.0
95	T.C.	19.5	20.5	20.4	21.8	23.6	21.2	21.6	21.1	23.0	24.5	22.9	22.7	21.7	24.2	25.4
	S.C.	18.9	17.5	14.8	14.5	11.5	20.5	19.0	16.8	16.7	12.8	22.2	20.6	18.9	18.9	14.2
	K.W.	2.0	2.0	1.9	2.1	2.0	2.0	2.0	2.0	2.1	2.1	2.1	2.0	2.0	2.1	2.1
105	T.C.	18.5	19.2	19.0	20.4	22.4	20.0	20.3	19.8	21.6	22.8	21.5	21.4	20.5	22.8	23.1
	S.C.	17.9	16.9	14.2	14.1	11.0	19.4	18.3	16.3	16.3	12.3	20.9	19.8	18.3	18.4	13.7
	K.W.	2.1	2.1	2.1	2.2	2.2	2.2	2.2	2.1	2.2	2.2	2.2	2.2	2.1	2.3	2.3
115	T.C.	17.5	17.8	17.6	19.1	21.3	18.9	19.0	18.5	20.2	21.1	20.3	20.2	19.4	21.4	20.8
	S.C.	16.9	16.3	13.6	13.7	10.5	18.3	17.7	15.7	15.8	11.8	19.7	19.1	17.8	17.9	13.1
	K.W.	2.3	2.2	2.2	2.3	2.4	2.3	2.3	2.2	2.4	2.4	2.4	2.4	2.3	2.4	2.5
125	T.C.	16.5	16.5	16.3	17.8	20.2	17.7	17.7	17.3	18.9	19.4	19.0	18.9	18.3	20.0	18.6
	S.C.	15.9	15.6	13.0	13.4	10.0	17.2	17.0	15.1	15.4	11.3	18.4	18.3	17.2	17.4	12.6
	K.W.	2.4	2.3	2.3	2.4	2.6	2.5	2.4	2.4	2.5	2.6	2.6	2.5	2.4	2.5	2.6

NOTE: ALL CAPACITIES ARE NET (KBTUH) WITH INDOOR FAN HEAT ALREADY DEDUCTED AT 1250 BTUH/1000 CFM.

### Multipliers for determining the performance with other indoor sections.

NOTE: For dry bulb temperatures different than those listed (between 73-87 F), sensible capacity increases by 1060 BTUH per 1000 CFM per degree above the listed temperature and decreases by 1060 BTUH per 1000 CFM per degree below the listed temperature.

Air Handler	Coil	T.C.	S.C.	KW
AHP24	–	1.00	1.02	1.00
AHP30	–	1.03	1.02	0.98
AV24	–	1.01	1.02	0.96
MA08B	FC/MC24B	1.00	1.00	1.00
MA08B	FC/MC30B	1.00	1.00	1.00
MA12B	FC/MC24B	1.00	1.00	1.00
MA12B	FC/MC30B	1.00	1.00	1.00
MV12B	FC/MC24B	1.02	1.00	0.97
MV12B	FC/MC30B	1.02	1.00	0.97
–	FC/MC/PC/UC24	1.00	1.00	1.00
–	FC/MC/PC/UC30	1.00	1.00	1.00
–	HD24	1.02	1.03	1.02
–	HC30	1.02	1.02	1.02

Variable Speed Furnace	Coil	T.C.	S.C.	KW
PV8*A12	FC/MC/PC24A	1.01	1.01	0.96
PV8*B16	FC/MC/PC24B	1.02	1.01	0.97
PV9*A12	FC/MC/PC24A	1.01	1.01	0.96
P(C,V)9*B12	FC/MC/PC24B	1.01	1.01	0.96
PV8*A12	FC/MC/PC30A	1.01	1.01	0.96
PV8*B16	FC/MC/PC30B	1.02	1.01	0.97
PV9*A12	FC/MC/PC30A	1.01	1.01	0.96
P(C,V)9*B12	FC/MC/PC30B	1.01	1.01	0.96
PV8*A12	HC30	1.03	1.02	0.98
PV9*A12	HC30	1.03	1.02	0.98
PV8*A12	HD24	1.03	1.04	0.99
PV9*A12	HD24	1.03	1.04	0.99

<b>COOLING PERFORMANCE DATA</b>																
<b>OUTDOOR UNIT MODEL NO.</b>		<b>CMB03011</b>														
<b>INDOOR COIL MODEL NO.</b>		<b>FC/MC/PC/UC30</b>														
<b>CONDENSER ENTERING AIR TEMPERATURE</b>	ID CFM	800					1000					1200				
	ID DB (°F)	80	80	75	80	80	80	80	75	80	80	80	80	75	80	80
	ID WB (°F)	57	62	62	67	72	57	62	62	67	72	57	62	62	67	72
65	T.C.	25.9	30.2	30.4	33.9	37.1	22.1	25.5	25.0	27.6	30.2	18.4	20.8	19.7	21.2	23.4
	S.C.	25.8	24.3	20.7	20.8	16.8	21.5	22.9	20.1	19.8	15.4	17.1	20.6	19.4	18.9	14.0
	K.W.	2.1	2.0	2.0	2.1	2.0	2.8	2.8	2.8	2.9	3.0	3.5	3.7	3.6	3.8	3.9
75	T.C.	25.2	28.7	28.8	32.1	35.5	23.3	26.0	25.5	28.2	31.2	21.4	23.2	22.2	24.3	26.9
	S.C.	25.0	23.4	20.0	20.0	16.1	22.7	23.3	20.2	20.1	15.7	20.4	23.1	20.4	20.2	15.3
	K.W.	2.2	2.2	2.2	2.3	2.3	2.7	2.8	2.8	2.8	2.9	3.2	3.3	3.3	3.4	3.5
85	T.C.	24.6	27.1	27.3	30.3	33.9	24.5	26.4	26.0	28.9	32.2	24.4	25.7	24.8	27.4	30.5
	S.C.	24.3	22.6	19.2	19.2	15.5	24.0	23.7	20.3	20.3	16.0	23.7	24.7	21.4	21.5	16.5
	K.W.	2.4	2.4	2.4	2.5	2.5	2.7	2.7	2.7	2.8	2.8	2.9	3.0	3.0	3.1	3.1
95	T.C.	24.0	25.5	25.7	28.5	32.3	25.7	26.8	26.5	29.5	33.1	27.4	28.1	27.4	30.5	34.0
	S.C.	23.5	21.7	18.4	18.4	14.9	25.3	24.0	20.4	20.6	16.3	27.0	26.4	22.4	22.8	17.8
	K.W.	2.6	2.6	2.6	2.7	2.7	2.6	2.6	2.6	2.7	2.7	2.7	2.7	2.7	2.7	2.8
105	T.C.	22.9	24.0	24.3	26.8	30.2	24.5	26.6	26.5	29.3	32.7	26.0	29.2	28.6	31.8	35.3
	S.C.	22.5	20.9	17.6	17.7	14.2	24.1	24.2	20.4	20.6	16.2	25.7	27.4	23.2	23.4	18.2
	K.W.	2.8	2.8	2.8	2.9	3.0	2.8	2.7	2.7	2.7	2.8	2.9	2.5	2.5	2.6	2.6
115	T.C.	21.9	22.5	23.0	25.1	28.1	23.3	26.4	26.4	29.1	32.3	24.7	30.2	29.9	33.1	36.6
	S.C.	21.4	20.2	16.8	17.1	13.5	22.9	24.3	20.4	20.6	16.0	24.3	28.5	24.0	24.1	18.6
	K.W.	3.0	3.0	3.0	3.1	3.2	3.1	2.7	2.7	2.8	2.8	3.1	2.4	2.4	2.4	2.4
125	T.C.	20.8	21.0	21.6	23.4	26.0	22.1	26.1	26.4	28.9	31.9	23.3	31.2	31.1	34.4	37.8
	S.C.	20.4	19.5	16.1	16.4	12.8	21.7	24.5	20.4	20.5	15.9	23.0	29.6	24.7	24.7	19.0
	K.W.	3.2	3.2	3.2	3.3	3.5	3.3	2.7	2.7	2.8	2.9	3.3	2.3	2.3	2.3	2.3

NOTE: ALL CAPACITIES ARE NET (KBTUH) WITH INDOOR FAN HEAT ALREADY DEDUCTED AT 1250 BTUH/1000 CFM.

**Multipliers for determining the performance with other indoor sections.**

NOTE: For dry bulb temperatures different than those listed (between 73-87 F), sensible capacity increases by 1060 BTUH per 1000 CFM per degree above the listed temperature and decreases by 1060 BTUH per 1000 CFM per degree below the listed temperature.

Air Handler	Coil	T.C.	S.C.	KW
AHP30	-	1.03	1.05	1.03
AHP36	-	1.05	1.07	1.05
AV36	-	1.01	1.05	0.96
MA12B	FC/MC30B	1.00	1.00	1.00
MA12B	FC/MC36B	1.00	1.01	1.00
MA16C	FC/MC36B	1.00	1.01	1.00
MV12B	FC/MC30B	1.01	1.00	0.97
MV12B	FC/MC36B	1.01	1.00	0.97
MV16C	FC/MC36C	1.01	1.00	0.97
-	FC/MC/PC/UC30	0.99	1.00	0.99
-	FC/MC/PC/UC36	1.00	1.00	1.00
-	HC30	1.00	1.00	1.00
-	HC36	1.01	1.04	1.01
-	HD36	1.01	1.04	1.01

Variable Speed Furnace	Coil	T.C.	S.C.	KW
PV8*A12	FC/MC/PC30A	1.01	1.01	1.01
PV8*B16	FC/MC/PC30B	1.01	1.01	0.97
PV9*A12	FC/MC/PC30A	1.01	1.01	1.01
P(C,V)9*B12	FC/MC/PC30B	1.01	1.01	1.01
PV8*A12	FC/MC/PC36A	1.01	1.01	1.01
PV8*B16	FC/MC/PC36B	1.02	1.01	0.98
PV8*C16	FC/MC/PC36C	1.02	1.01	0.98
PV8*C20	FC/MC/PC36C	1.02	1.01	0.98
PV9*A12	FC/MC/PC36A	1.01	1.01	1.01
P(C,V)9*B12	FC/MC/PC36B	1.01	1.01	0.97
P(C,V)9*C16	FC/MC/PC36C	1.01	1.01	0.97
P(C,V)9*C20	FC/MC/PC36C	1.02	1.01	0.98
PV8*A12	HC30	1.03	1.03	0.98
PV9*A12	HC30	1.03	1.03	0.98
PV8*B16	HC36	1.05	1.05	1.00
P(C,V)9*B12	HC36	1.05	1.04	1.00
PV8*A12	HD36	1.05	1.04	1.00
PV8*B16	HD36	1.05	1.05	1.01
PV8*C16	HD36	1.05	1.05	1.01
PV8*C20	HD36	1.05	1.05	1.01
PV9*A12	HD36	1.05	1.04	1.00
P(C,V)9*B12	HD36	1.05	1.04	1.00
P(C,V)9*C16	HD36	1.05	1.05	1.00
P(C,V)9*C20	HD36	1.05	1.05	1.01

<b>COOLING PERFORMANCE DATA</b>																
<b>OUTDOOR UNIT MODEL NO.</b>		<b>CMB03611</b>														
<b>INDOOR COIL MODEL NO.</b>		<b>FC/MC/PC/UC42</b>														
<b>CONDENSER ENTERING AIR TEMPERATURE</b>	ID CFM	1000					1200					1400				
	ID DB (°F)	80	80	75	80	80	80	80	75	80	80	80	80	75	80	80
	ID WB (°F)	57	62	62	67	72	57	62	62	67	72	57	62	62	67	72
65	T.C.	33.6	39.7	39.2	43.6	51.0	35.9	40.3	39.7	44.0	49.5	38.3	40.9	40.3	44.5	48.1
	S.C.	32.3	32.8	28.0	27.8	22.3	34.6	36.0	30.7	29.1	23.5	36.9	39.3	33.3	30.3	24.7
	K.W.	2.5	2.5	2.5	2.6	2.6	2.5	2.6	2.6	2.6	2.6	2.6	2.6	2.6	2.6	2.6
75	T.C.	32.2	37.0	36.7	40.8	47.2	34.2	37.4	37.2	41.2	46.3	36.1	37.9	37.6	41.6	45.4
	S.C.	31.1	31.3	26.8	26.7	21.3	32.9	33.8	29.2	28.2	22.6	34.7	36.4	31.7	29.8	23.9
	K.W.	2.7	2.7	2.7	2.8	2.8	2.7	2.8	2.7	2.8	2.9	2.8	2.8	2.8	2.8	2.9
85	T.C.	30.8	34.2	34.2	38.0	43.4	32.4	34.5	34.6	38.3	43.1	33.9	34.9	35.0	38.7	42.7
	S.C.	29.8	29.8	25.6	25.6	20.4	31.2	31.7	27.8	27.4	21.7	32.6	33.5	30.1	29.3	23.1
	K.W.	2.9	2.9	2.9	3.0	3.1	2.9	2.9	2.9	3.0	3.1	3.0	3.0	3.0	3.0	3.1
95	T.C.	29.4	31.4	31.7	35.1	39.6	30.6	31.6	32.0	35.5	39.8	31.7	31.9	32.4	35.9	40.0
	S.C.	28.5	28.3	24.5	24.5	19.4	29.5	29.5	26.4	26.6	20.8	30.5	30.7	28.4	28.7	22.2
	K.W.	3.0	3.1	3.1	3.2	3.3	3.1	3.1	3.1	3.2	3.3	3.2	3.2	3.2	3.3	3.4
105	T.C.	27.4	29.4	29.6	33.0	37.0	28.6	29.6	29.9	33.2	37.1	29.7	29.8	30.2	33.3	37.2
	S.C.	26.5	27.0	23.4	23.6	18.6	27.5	27.8	25.3	25.6	19.9	28.5	28.7	27.1	27.6	21.3
	K.W.	3.2	3.3	3.3	3.4	3.5	3.3	3.3	3.3	3.4	3.6	3.4	3.4	3.3	3.5	3.6
115	T.C.	25.5	27.5	27.6	30.9	34.5	26.6	27.6	27.8	30.9	34.5	27.7	27.8	28.0	30.9	34.5
	S.C.	24.4	25.7	22.5	22.8	17.7	25.5	26.2	24.1	24.7	19.0	26.6	26.7	25.8	26.6	20.3
	K.W.	3.4	3.5	3.4	3.6	3.8	3.5	3.5	3.5	3.6	3.8	3.6	3.6	3.5	3.7	3.8
125	T.C.	23.5	25.6	25.5	28.8	31.9	24.6	25.7	25.7	28.6	31.8	25.6	25.8	25.9	28.4	31.7
	S.C.	22.4	24.5	21.5	22.0	16.9	23.5	24.6	23.0	23.7	18.2	24.7	24.8	24.5	25.5	19.4
	K.W.	3.6	3.6	3.6	3.8	4.0	3.7	3.7	3.7	3.8	4.0	3.8	3.8	3.7	3.9	4.1

NOTE: ALL CAPACITIES ARE NET (KBTUH) WITH INDOOR FAN HEAT ALREADY DEDUCTED AT 1250 BTUH/1000 CFM.

### Multipliers for determining the performance with other indoor sections.

NOTE: For dry bulb temperatures different than those listed (between 73-87 F), sensible capacity increases by 1060 BTUH per 1000 CFM per degree above the listed temperature and decreases by 1060 BTUH per 1000 CFM per degree below the listed temperature.

Air Handler	Coil	T.C.	S.C.	KW
AHP36	–	1.02	1.05	1.02
AHP42	–	1.02	1.05	1.02
AHP/SHP60	–	1.02	1.05	0.98
AV/SV48	–	1.02	1.05	1.02
MA12B	FC/MC35B	1.00	1.00	1.00
MA16C	FC/MC35C	1.00	1.00	1.00
MA12B	FC/MC42B	1.00	1.00	1.00
MA14D	FC/MC/PC48D	1.02	1.02	1.02
MA16C	FC/MC42C	1.00	1.00	1.00
MA16C	FC/MC48C	1.02	1.02	1.02
MV12B	FC/MC35	1.01	0.98	1.01
MV16C	FC/MC35	1.01	0.99	0.97
MV12B	FC/MC42B	1.01	0.98	1.01
MV16C	FC/MC42C	1.01	0.99	0.97
MV16C	FC/MC48C	1.03	1.01	0.98
MV20D	FC/MC48D	1.03	1.01	0.98
–	FC/MC/PC/UC42	1.00	1.00	1.00
–	FC/MC/PC/UC48	1.02	1.02	1.02
–	HC42	1.02	1.02	1.02
–	HD48	1.02	1.00	1.02

Variable Speed Furnace	Coil	T.C.	S.C.	KW
PV8*B16	FC/MC/PC35B	1.01	1.01	1.01
PV8*C16	FC/MC/PC35C	1.02	1.01	0.97
PV8*C20	FC/MC/PC35C	1.02	1.01	0.97
P(C,V)9*B12	FC/MC/PC35B	1.01	1.00	1.01
P(C,V)9*C16	FC/MC/PC35C	1.01	1.01	1.01
P(C,V)9*C20	FC/MC/PC35C	1.01	1.01	1.01
PV8*B16	FC/MC/PC42B	1.01	1.01	1.01
PV8*C16	FC/MC/PC42C	1.02	1.01	0.97
PV8*C20	FC/MC/PC42C	1.02	1.01	0.97
P(C,V)9*B12	FC/MC/PC42B	1.01	1.00	1.01
P(C,V)9*C16	FC/MC/PC42C	1.01	1.01	1.01
P(C,V)9*C20	FC/MC/PC42C	1.01	1.01	1.01
PV8*C16	FC/MC/PC48C	1.03	1.03	0.99
PV8*C20	FC/MC/PC48C	1.03	1.03	0.99
P(C,V)9*C16	FC/MC/PC48C	1.03	1.03	0.98
P(C,V)9*C20	FC/MC/PC48C	1.03	1.03	0.98
P(C,V)9*D20	FC/MC/PC48D	1.03	1.03	0.98
PV8*C16	HC42	1.02	1.02	0.98
PV8*C20	HC42	1.03	1.02	0.98
P(C,V)9*C16	HC42	1.02	1.02	0.98
P(C,V)9*C20	HC42	1.02	1.02	0.98
PV8*C16	HD48	1.04	1.03	0.99
PV8*C20	HD48	1.05	1.03	1.00
P(C,V)9*C16	HD48	1.04	1.03	0.99
P(C,V)9*C20	HD48	1.04	1.03	0.99
P(C,V)9*D20	HD48	1.04	1.03	0.99

<b>COOLING PERFORMANCE DATA</b>																
<b>OUTDOOR UNIT MODEL NO.</b>		<b>CMB04211</b>														
<b>INDOOR COIL MODEL NO.</b>		<b>FC/MC/PC/UC48</b>														
<b>CONDENSER ENTERING AIR TEMPERATURE</b>	ID CFM	1200					1400					1600				
	ID DB (°F)	80	80	75	80	80	80	80	75	80	80	80	80	75	80	80
	ID WB (°F)	57	62	62	67	72	57	62	62	67	72	57	62	62	67	72
65	T.C.	37.2	43.6	42.3	46.6	49.6	42.4	45.5	43.4	47.9	50.7	47.6	47.5	44.6	49.2	51.7
	S.C.	36.9	36.9	31.0	30.6	23.5	39.5	39.6	33.4	33.2	25.4	42.1	42.4	35.7	35.8	27.3
	K.W.	2.8	2.7	2.7	2.7	2.7	2.8	2.7	2.7	2.7	2.7	2.7	2.7	2.7	2.7	2.7
75	T.C.	36.6	42.1	40.8	44.7	47.7	41.4	43.9	41.8	45.8	48.5	46.1	45.7	42.9	46.8	49.3
	S.C.	36.2	36.0	30.1	29.9	22.9	38.4	38.6	32.5	32.3	24.7	40.7	41.2	34.8	34.8	26.4
	K.W.	3.1	3.0	3.0	3.0	3.1	3.1	3.0	3.0	3.1	3.1	3.0	3.1	3.0	3.1	3.1
85	T.C.	36.0	40.6	39.3	42.8	45.7	40.3	42.3	40.3	43.6	46.3	44.7	43.9	41.2	44.4	46.9
	S.C.	35.5	35.1	29.3	29.2	22.4	37.4	37.6	31.6	31.5	24.0	39.3	40.0	33.9	33.9	25.5
	K.W.	3.4	3.4	3.4	3.4	3.4	3.4	3.4	3.4	3.4	3.4	3.4	3.4	3.4	3.4	3.5
95	T.C.	35.4	39.1	37.8	40.9	43.7	39.3	40.6	38.7	41.5	44.0	43.3	42.2	39.6	42.1	44.4
	S.C.	34.7	34.3	28.4	28.5	21.8	36.3	36.5	30.7	30.7	23.2	37.9	38.8	33.1	32.9	24.7
	K.W.	3.7	3.7	3.7	3.8	3.8	3.7	3.7	3.7	3.8	3.8	3.8	3.8	3.7	3.8	3.8
105	T.C.	33.6	37.3	35.7	39.0	41.2	37.6	38.9	36.6	39.6	41.5	41.6	40.5	37.4	40.2	41.9
	S.C.	32.9	32.9	27.3	27.6	21.1	34.6	34.9	29.6	29.9	22.5	36.3	36.9	31.9	32.1	23.9
	K.W.	4.3	4.2	4.2	4.3	4.3	4.3	4.3	4.2	4.3	4.3	4.3	4.3	4.2	4.3	4.4
115	T.C.	31.9	35.6	33.8	37.1	38.7	36.0	37.2	34.6	37.8	39.1	40.0	38.8	35.4	38.4	39.4
	S.C.	31.1	31.7	26.3	26.8	20.4	32.9	33.4	28.6	29.0	21.8	34.7	35.1	30.8	31.3	23.2
	K.W.	4.8	4.8	4.7	4.8	4.8	4.8	4.8	4.7	4.8	4.8	4.8	4.8	4.7	4.8	4.9
125	T.C.	30.2	33.9	31.8	35.2	36.3	34.3	35.5	32.5	35.9	36.6	38.4	37.1	33.3	36.7	37.0
	S.C.	29.3	30.4	25.3	26.0	19.8	31.3	31.9	27.5	28.2	21.1	33.2	33.3	29.8	30.5	22.4
	K.W.	5.4	5.3	5.3	5.3	5.3	5.3	5.3	5.3	5.3	5.3	5.3	5.3	5.3	5.3	5.4

NOTE: ALL CAPACITIES ARE NET (KBTUH) WITH INDOOR FAN HEAT ALREADY DEDUCTED AT 1250 BTUH/1000 CFM.

### Multipliers for determining the performance with other indoor sections.

NOTE: For dry bulb temperatures different than those listed (between 73-87 F), sensible capacity increases by 1060 BTUH per 1000 CFM per degree above the listed temperature and decreases by 1060 BTUH per 1000 CFM per degree below the listed temperature.

Air Handler	Coil	T.C.	S.C.	KW
AHP/SHP48	-	1.01	1.02	1.01
AHP/SHP60	-	1.02	1.03	0.98
AV/SV48	-	1.01	1.03	0.96
MA16C	FC/MC48C	1.00	1.00	1.00
MV16C	FC/MC48C	0.99	0.98	0.99
MV20D	FC/MC48D	0.99	0.99	0.94
-	FC/MC/PC/UC48	1.00	1.01	1.00
-	HC42	0.99	1.00	0.99
-	HD48	1.00	0.99	1.00

Variable Speed Furnace	Coil	T.C.	S.C.	KW
PV8*C16	FC/MC/PC48C	1.00	1.00	1.00
PV8*C20	FC/MC/PC48C	0.99	1.01	0.99
P(C,V)9*C16	FC/MC/PC48C	1.00	1.00	1.00
P(C,V)9*C20	FC/MC/PC48C	1.00	1.00	1.00
P(C,V)9*D20	FC/MC/PC48D	1.00	1.00	1.00
PV8*C16	HC42	1.00	1.00	1.00
PV8*C20	HC42	1.00	1.00	1.00
P(C,V)9*C16	HC42	1.00	1.00	1.00
P(C,V)9*C20	HC42	1.00	1.01	1.00
PV8*C16	HD48	1.01	1.02	1.01
PV8*C20	HD48	1.02	1.02	1.02
P(C,V)9*C16	HD48	1.01	1.02	1.01
P(C,V)9*C20	HD48	1.01	1.02	1.01
P(C,V)9*D20	HD48	1.01	1.02	1.01

<b>COOLING PERFORMANCE DATA</b>																
<b>OUTDOOR UNIT MODEL NO.</b>		<b>CMB04811</b>														
<b>INDOOR COIL MODEL NO.</b>		<b>FC/MC/PC/UC48</b>														
<b>CONDENSER ENTERING AIR TEMPERATURE</b>	ID CFM	1400					1600					1800				
	ID DB (°F)	80	80	75	80	80	80	80	75	80	80	80	80	75	80	80
	ID WB (°F)	57	62	62	67	72	57	62	62	67	72	57	62	62	67	72
65	T.C.	46.8	48.9	48.6	52.4	57.4	48.3	49.6	49.4	53.3	58.2	49.9	50.3	50.1	54.1	58.9
	S.C.	45.7	42.6	36.0	35.4	27.5	47.3	45.0	38.0	37.4	28.8	48.9	47.5	39.9	39.4	30.0
	K.W.	2.9	3.0	3.0	3.0	3.0	2.9	3.0	3.0	3.0	3.0	3.0	3.0	3.0	3.0	3.0
75	T.C.	45.0	47.0	46.7	50.4	55.4	46.5	47.6	47.4	51.2	56.0	47.9	48.2	48.1	52.0	56.6
	S.C.	44.0	41.3	34.9	34.3	26.8	45.5	43.7	37.0	36.4	28.1	47.0	46.1	39.0	38.4	29.3
	K.W.	3.4	3.4	3.4	3.4	3.4	3.4	3.4	3.4	3.4	3.4	3.4	3.4	3.4	3.4	3.4
85	T.C.	43.3	45.0	44.8	48.4	53.4	44.6	45.6	45.4	49.1	53.8	45.9	46.2	46.1	49.8	54.3
	S.C.	42.4	39.9	33.8	33.3	26.1	43.7	42.3	36.0	35.3	27.3	45.1	44.8	38.1	37.3	28.6
	K.W.	3.8	3.8	3.8	3.8	3.9	3.8	3.8	3.8	3.8	3.9	3.8	3.8	3.8	3.9	3.9
95	T.C.	41.5	43.0	42.9	46.4	51.4	42.8	43.6	43.5	47.0	51.7	44.0	44.2	44.0	47.6	52.0
	S.C.	40.7	38.5	32.7	32.3	25.5	42.0	41.0	35.0	34.3	26.6	43.2	43.4	37.2	36.3	27.8
	K.W.	4.2	4.2	4.2	4.3	4.3	4.2	4.3	4.2	4.3	4.3	4.2	4.3	4.2	4.3	4.3
105	T.C.	39.3	40.8	40.9	44.0	48.7	40.6	41.4	41.3	44.5	48.9	41.8	41.9	41.6	45.0	49.2
	S.C.	38.6	37.5	31.7	31.5	24.7	39.8	39.3	34.0	33.4	25.9	41.0	41.2	36.2	35.4	27.1
	K.W.	4.9	4.9	4.8	4.9	4.9	4.9	4.9	4.8	4.9	4.9	4.9	4.9	4.8	4.9	4.9
115	T.C.	37.2	38.7	38.9	41.7	46.0	38.4	39.2	39.1	42.2	46.2	39.7	39.7	39.3	42.6	46.4
	S.C.	36.5	36.4	30.8	30.8	23.9	37.7	37.7	33.0	32.6	25.2	38.9	39.0	35.3	34.5	26.5
	K.W.	5.5	5.5	5.4	5.5	5.5	5.5	5.5	5.4	5.5	5.5	5.5	5.5	5.4	5.5	5.5
125	T.C.	35.1	36.6	36.8	39.4	43.4	36.3	37.1	36.9	39.8	43.5	37.6	37.6	37.0	40.1	43.7
	S.C.	34.4	35.4	29.8	30.0	23.1	35.6	36.1	32.1	31.8	24.4	36.9	36.9	34.3	33.5	25.8
	K.W.	6.2	6.1	6.1	6.1	6.1	6.2	6.1	6.0	6.1	6.1	6.1	6.1	6.0	6.1	6.1

NOTE: ALL CAPACITIES ARE NET (KBTUH) WITH INDOOR FAN HEAT ALREADY DEDUCTED AT 1250 BTUH/1000 CFM.

### Multipliers for determining the performance with other indoor sections.

NOTE: For dry bulb temperatures different than those listed (between 73-87 F), sensible capacity increases by 1060 BTUH per 1000 CFM per degree above the listed temperature and decreases by 1060 BTUH per 1000 CFM per degree below the listed temperature.

Air Handler	Coil	T.C.	S.C.	KW
AHP/SHP48	–	1.02	1.05	1.02
AHP/SHP60	–	1.01	1.03	1.01
AV/SV48	–	1.00	1.01	1.00
F*FV060	–	1.01	1.03	1.01
MA16C	FC/MC48C	1.02	1.04	1.02
MA20D	FC/MC48D	1.00	1.00	1.00
MV16C	FC/MC48C	1.00	0.98	1.00
MV20D	FC/MC48D	1.00	0.98	1.00
–	FC/MC/PC/UC48	1.00	1.01	1.00
–	HC42	0.99	0.99	0.99
–	HD48	1.01	0.99	1.01

Variable Speed Furnace	Coil	T.C.	S.C.	KW
PV8*C16	FC/MC/PC48C	0.99	0.97	0.99
PV8*C20	FC/MC/PC48C	1.00	1.00	1.00
P(C,V)9*C16	FC/MC/PC48C	1.00	1.00	1.00
P(C,V)9*C20	FC/MC/PC48C	1.00	1.00	1.00
P(C,V)9*D20	FC/MC/PC48D	1.00	1.00	1.00
PV8*C16	HC42	0.99	0.96	0.99
PV8*C20	HC42	1.00	0.99	1.00
P(C,V)9*C16	HC42	0.99	0.99	0.99
P(C,V)9*C20	HC42	0.99	0.99	0.99
PV8*C16	HD48	1.01	0.99	1.01
PV8*C20	HD48	1.02	1.02	1.02
P(C,V)9*C16	HD48	1.01	1.02	1.01
P(C,V)9*C20	HD48	1.02	1.02	1.02
P(C,V)9*D20	HD48	1.02	1.02	1.02

<b>COOLING PERFORMANCE DATA</b>																
<b>OUTDOOR UNIT MODEL NO.</b>		<b>CMB06011</b>														
<b>INDOOR COIL MODEL NO.</b>		<b>FC/MC/PC/UC60</b>														
<b>CONDENSER ENTERING AIR TEMPERATURE</b>	ID CFM	1600					1800					2000				
	ID DB (°F)	80	80	75	80	80	80	80	75	80	80	80	80	75	80	80
	ID WB (°F)	57	62	62	67	72	57	62	62	67	72	57	62	62	67	72
65	T.C.	54.2	57.8	53.9	59.6	61.3	56.6	59.2	55.5	61.3	63.0	59.0	60.6	57.0	62.9	64.8
	S.C.	51.0	47.8	39.2	39.5	28.9	53.2	51.1	41.4	42.0	30.9	55.4	54.4	43.6	44.5	32.9
	K.W.	3.4	3.4	3.6	3.5	3.5	3.4	3.4	3.5	3.5	3.5	3.4	3.5	3.4	3.5	3.5
75	T.C.	53.1	55.7	52.3	57.8	59.4	55.4	57.2	53.8	59.3	60.8	57.6	58.7	55.3	60.9	62.2
	S.C.	49.5	47.0	38.8	38.8	28.8	51.6	49.9	41.0	41.3	30.5	53.7	52.9	43.2	43.8	32.1
	K.W.	3.9	4.0	4.1	4.0	4.0	4.0	4.0	4.0	4.0	4.1	4.0	4.0	4.0	4.0	4.1
85	T.C.	52.0	53.7	50.6	55.9	57.6	54.1	55.2	52.1	57.4	58.7	56.2	56.8	53.6	58.9	59.7
	S.C.	48.0	46.2	38.3	38.1	28.7	49.9	48.8	40.5	40.6	30.0	51.9	51.4	42.7	43.1	31.3
	K.W.	4.5	4.5	4.5	4.5	4.6	4.5	4.5	4.5	4.5	4.6	4.5	4.5	4.5	4.5	4.6
95	T.C.	50.8	51.6	49.0	54.1	55.8	52.9	53.2	50.4	55.5	56.5	54.9	54.9	51.8	56.9	57.2
	S.C.	46.5	45.4	37.8	37.4	28.5	48.3	47.6	40.0	39.9	29.5	50.2	49.9	42.3	42.4	30.5
	K.W.	5.0	5.0	5.0	5.0	5.1	5.0	5.0	5.0	5.0	5.1	5.0	5.0	5.0	5.1	5.2
105	T.C.	48.7	49.2	46.6	51.5	52.6	50.7	50.9	47.8	52.7	53.2	52.6	52.6	49.0	54.0	53.9
	S.C.	44.5	43.8	36.4	36.2	27.2	46.2	45.8	38.7	38.7	28.3	48.0	47.8	40.9	41.2	29.5
	K.W.	5.7	5.7	5.7	5.7	5.8	5.8	5.7	5.7	5.8	5.8	5.8	5.7	5.7	5.8	5.9
115	T.C.	46.7	46.9	44.2	49.0	49.4	48.5	48.7	45.2	50.1	50.0	50.4	50.4	46.3	51.1	50.6
	S.C.	42.6	42.2	35.1	35.1	25.9	44.2	44.0	37.4	37.5	27.2	45.8	45.9	39.6	40.0	28.5
	K.W.	6.5	6.4	6.4	6.4	6.5	6.5	6.4	6.4	6.4	6.5	6.5	6.4	6.4	6.5	6.6
125	T.C.	44.7	44.6	41.9	46.5	46.2	46.4	46.4	42.7	47.4	46.8	48.1	48.3	43.5	48.2	47.4
	S.C.	40.7	40.6	33.8	34.0	24.6	42.2	42.3	36.1	36.4	26.0	43.7	43.9	38.4	38.8	27.5
	K.W.	7.2	7.1	7.1	7.1	7.2	7.2	7.1	7.1	7.1	7.2	7.2	7.1	7.1	7.2	7.3

NOTE: ALL CAPACITIES ARE NET (KBTUH) WITH INDOOR FAN HEAT ALREADY DEDUCTED AT 1250 BTUH/1000 CFM.

### Multipliers for determining the performance with other indoor sections.

NOTE: For dry bulb temperatures different than those listed (between 73-87 F), sensible capacity increases by 1060 BTUH per 1000 CFM per degree above the listed temperature and decreases by 1060 BTUH per 1000 CFM per degree below the listed temperature.

<b>Air Handler</b>	<b>Coil</b>	<b>T.C.</b>	<b>S.C.</b>	<b>KW</b>
AHP/SHP60	–	1.00	1.01	1.00
AV/SV60	–	0.99	1.00	0.99
F*FV060	–	1.00	1.01	1.00
MA20D	FC/MC60D	1.00	1.00	1.00
MA20D	MC61D	1.01	1.01	1.01
MV20D	FC/MC60D	1.00	0.98	1.00
MV20D	FC/MC61D	0.99	0.99	0.99
–	FC/MC/PC/UC60	0.99	1.00	0.99
–	MC61D	1.01	1.01	1.01
–	HC60	1.00	1.00	1.00
–	HD60	0.99	1.01	0.99

<b>Variable Speed Furnace</b>	<b>Coil</b>	<b>T.C.</b>	<b>S.C.</b>	<b>KW</b>
PV8*C20	FC/PC60C	1.00	0.98	1.00
P(C,V)9*C20	FC/PC60C	0.99	0.96	0.99
P(C,V)9*D20	FC/MC/PC60D	0.99	0.96	0.99
PV8*C20	MC61D	1.00	0.99	1.00
P(C,V)9*C20	MC61D	0.99	0.96	0.99
P(C,V)9*D20	MC61D	1.00	0.96	1.00
PV8*C20	HC60	1.00	0.98	1.00
P(C,V)9*D20	HC60	0.99	0.96	0.99
PV8*C20	HD60	1.00	0.99	1.00
P(C,V)9*C20	HD60	0.99	0.96	0.99
P(C,V)9*D20	HD60	1.00	0.96	1.00

## NOTES

# NOTES

Subject to change without notice. Printed in U.S.A.  
Copyright © by York International Corp. 2007. All rights reserved.

256913-YTG-E-0607  
Supersedes: 256913-YTG-D-0906

---

**Unitary  
Products  
Group**

**5005  
York  
Drive**

**Norman  
OK  
73069**