



Heating and Air Conditioning

SPLIT-SYSTEM AIR CONDITIONERS

13 SEER

AY012MA THRU 030

(1 THRU 2.5 NOMINAL TONS, 1 PH)



CERTIFICATION APPLIES ONLY
WHEN THE COMPLETE
SYSTEM IS LISTED
WITH ARI.



ISO 9001
Certified Quality
Management System

Due to continuous product improvement, specifications are subject to change without notice.

Visit us on the web at www.york.com for the most up-to-date technical information.

Additional rating information can be found at www.ari.org/aridirectory

DESCRIPTION

The 13 SEER Series condensing unit is the outdoor part of a versatile system of air conditioning. It is designed to be custom-matched with one of UPG's complete line of evaporator sections, each designed to serve a specific function.

WARRANTY

5-year limited parts warranty.

5-year limited compressor warranty.

FEATURES

- **QUALITY CONDENSER COILS** - The coil is constructed of aluminum microchannel tubing and enhanced aluminum fins for increased efficiency and corrosion protection.
- **COIL PROTECTION** - Coils are protected from damage by a polymer mesh applied between the coil face, and a coated steel coil guard.
- **PROTECTED COMPRESSOR** - Compressors are internally protected against high pressure and temperature. This is accomplished by the simultaneous operation of high pressure relief valve and a temperature sensor which protects the compressor if undesirable operating conditions occur. A liquid line filter-drier further protects the compressor.
- **DURABLE FINISH** - The cabinet is made of pre-painted steel. The pre-treated flat galvanized steel provides a better paint-to-steel bond, which resists corrosion and rust creep. Special primer formulas and matted champagne finish insure less fading when exposed to sunlight.
- **LOWER INSTALLED COST** - Installation time and costs are reduced by easy power and control wiring connections. The small base dimension means less space is required on the ground or roof.
- **TOP DISCHARGE** - The warm air from the top mounted fan is blown away from the structure and any landscaping. This allows compact location on multi-unit applications.
- **LOW OPERATING SOUND LEVEL** - The upward air flow carries the normal operating noise away from the living area. The rigid top panel effectively isolates any motor sound. Isolator mounted compressor and the condenser coil muffle the normal fan motor and compressor operating sounds.
- **LOW MAINTENANCE** - Long life permanently lubricated motor-bearings need no annual servicing.
- **EASY SERVICE ACCESS** - Fully exposed refrigerant connections and a single panel covering the electrical controls make for easy servicing of the unit.
- **SECURED SERVICE VALVES** - Secured re-usable service valves are provided on both the liquid and vapor sweat connections for ease of evacuating and charging.
- **U.L. AND C.U.L. LISTED** - Approved for outdoor application.

Certified in accordance with the Unitary Small Equipment certification program, which is based on ARI Standard 210/240.

PHYSICAL AND ELECTRICAL DATA

MODEL		AY012MA322	AY018MA322	AY024MA322	AY030MA322
Unit Supply Voltage		208-230V, 1 ϕ , 60Hz			
Normal Voltage Range ¹		187 to 252			
Minimum Circuit Ampacity		8.8	9.5	13.6	14.0
Max. Overcurrent Device Amps ²		15	15	20	20
Min. Overcurrent Device Amps ³		10	10	15	15
Compressor Type		Rotary	Rotary	Recip	Recip
Compressor Amps	Rated Load	6.7	7.2	10.2	10.6
	Locked Rotor	33	40	54	61
Crankcase Heater		No	No	No	No
Fan Motor Amps	Rated Load	0.5	0.5	0.8	0.8
Fan Diameter Inches		17-1/2	17-1/2	17-1/2	17-1/2
Fan Motor	Rated HP	1/12	1/12	1/8	1/8
	Nominal RPM	1100	1100	1075	1075
	Nominal CFM	1450	1450	1750	1850
Coil	Face Area Sq. Ft.	7.26	7.89	8.77	10.17
	Rows Deep	1	1	1	1
	Fin/Inches	23	23	23	23
Liquid Line Set OD (Field Installed)		3/8"	3/8"	3/8"	3/8"
Vapor Line Set OD (Field Installed)		5/8"	5/8"	3/4"	3/4"
Unit Charge (Lbs. - Oz.) ⁴		2 - 13	3 - 0	3 - 0	3 - 11
Charge Per Foot, Oz.		0.66	0.66	0.68	0.68
Operating Weight Lbs.		85	100	140	145

1. Rated in accordance with ARI Standard 110, utilization range "A".
2. Dual element fuses or HACR circuit breaker. Maximum allowable overcurrent protection.
3. Dual element fuses or HACR circuit breaker. Minimum recommended overcurrent protection.
4. The Unit Charge is correct for the outdoor unit, matched indoor coil and 15 feet of refrigerant tubing. For tubing lengths other than 15 feet, add or subtract the amount of refrigerant, using the difference in length multiplied by the per foot value.

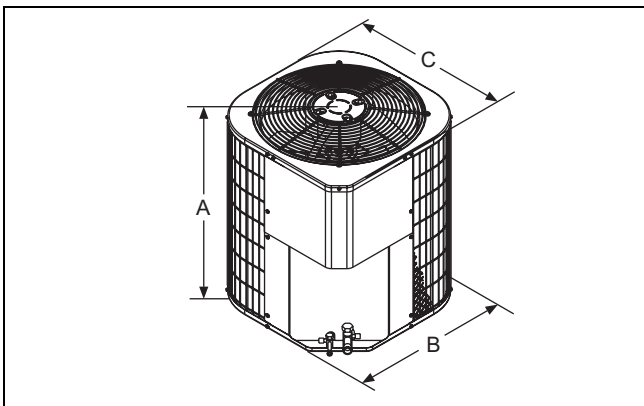

1. Including Fan Guard.

All dimensions are in inches. They are subject to change without notice. certified dimensions will be provided upon request.

Unit Model	Dimensions (Inches)			Refrigerant Connection Service Valve Size	
	A ¹	B	C	Liquid	Vapor
012	22-1/2	21-3/4	21-3/4	3/8"	3/4"
018	24-1/4	21-3/4	21-3/4		
024	26-3/4	21-3/4	21-3/4		
030	30-3/4	21-3/4	21-3/4		

Additional R-22 Charge/Orifice Size for Various Matched Systems - 1 Phase				
Outdoor Unit	AY012MA322	AY018MA322	AY024MA322	AY030MA322
Required Orifice or TXV ^{1,2}	0.048 / 2A	0.053 / 2A	0.059 / 2A 0.061	0.067 / 2A
Factory R-22 Charge, lbs-oz	2 - 13	3 - 0	3 - 0	3 - 11
Indoor Coil ^{3,4}	Additional Charge, Oz			
FC/MC/PC/UC18A2A	0	0	—	—
FC/MC/PC/UC18B2A	0	0	—	—
FC/MC/PC/UC24A2A	—	2	—	—
FC/MC/PC/UC24B2A	—	2	—	—
FC/MC/PC/UC30A2A	—	2	—	—
FC/MC/PC/UC30B2A	—	2	—	—
FC/MC/PC/UC35B2A	—	—	5	0
FC/MC/PC/UC35C2A	—	—	5	0
FC/MC/PC/UC36A2A	—	—	5	—
FC/MC/PC/UC36B2A	—	—	5	—
FC/MC/PC/UC36C2A	—	—	5	—
HC18A2A	0	0	—	—
HC30A2A	—	—	5	—
AHP18B2A	0	0	—	—
AHP24B2A	—	0	—	—
AHP30B2A	—	—	5	0
AHP30C2A	—	—	5	0
AV24B2A	—	0	—	—
AV36C2A	—	—	8	4
FC/MC/PC/UC18A3X	48 + 0	53 + 0	—	—
FC/MC/PC/UC18B3X	48 + 0	53 + 0	—	—
FC/MC/PC/UC24A3X	—	53 + 2	—	—
FC/MC/PC/UC24B3X	—	53 + 2	—	—
FC/MC/PC/UC30A3X	—	53 + 2	—	—
FC/MC/PC/UC30B3X	—	53 + 2	—	—
FC/MC/PC/UC35B3X	—	—	61 + 5	67 + 0
FC/MC/PC/UC35C3X	—	—	61 + 5	67 + 0
FC/MC/PC/UC36A3X	—	—	5	—
FC/MC/PC/UC36B3X	—	—	5	—
FC/MC/PC/UC36C3X	—	—	5	—
HC18A3X	48 + 0	53 + 0	—	—
HC30A3X	—	—	5	—
AHP18B3X	48 + 0	53 + 0	—	—
AHP30C3X	—	—	61 + 5	67 + 0
AV24B3X	—	53 + 0	—	—
AV36C3X	—	—	61 + 8	67 + 4

FOOTNOTES:

1. For applications requiring a TXV use 1TVM series kit.
2. Approved orifice shipped with outdoor unit.
3. Systems matched with furnace or air handlers not equipped with blower-off delays may require blower Time Delay Kit 2FD06700224.
4. PC coils cannot be used in downflow or horizontal applications. FC coils cannot be used in horizontal applications.

All models require Start Kits for TXV matches. Refer to Price Pages for kit number reference.

PROCEDURES:

1. Unit factory charge listed on the unit nameplate includes refrigerant for the condenser, the smallest evaporator and 15 feet of interconnecting line tubing.
2. Verify the TXV or orifice and additional charge required for specific evaporator coil in the system using the above table.
3. Additional charge for the amount of interconnecting line tubing greater than 15 feet at the rate specified in Physical and Electrical Data Table.
4. Permanently mark the unit nameplate with the total system charge. Total System Charge = Base Charge (as shipped) + adder for evaporator + adder for line set.

COOLING CAPACITY - With Air Handler Coils

UNIT MODEL	AIR HANDLER		COIL ¹ MODEL	COOLING				
	MODEL	W		RATED CFM	NET MBH		SEER	EER
					TOTAL	SENS.		
1 PH 13 SEER AC WITH MA								
AY018MA322	MA08B	17	FC/MC18B	600	18.0	13.4	13.0	11.0
AY024MA322	MA08B	17	FC/MC36B	800	24.0	17.5	13.0	11.0
AY030MA322	MA12B	17	FC/MC35B	1000	28.6	20.8	13.0	11.0
1 PH 13 SEER AC WITH MV - VARIABLE SPEED								
AY018MA322	MV12B	17	FC/MC18B	600	18.0	13.4	14.0	12.0
AY024MA322	MV12B	17	FC/MC35B	800	24.0	17.5	14.0	12.0
	MV12B	17	FC/MC36B	800	24.0	17.5	14.0	12.0
AY030MA322	MV12B	17	FC/MC35B	1000	28.6	20.8	14.0	12.0
	MV16C	21	FC/MC35C	1000	28.6	20.8	14.0	12.0
1 PH 13 SEER AC WITH AV - VARIABLE SPEED								
AY018MA322	AV24	17	–	600	18.0	13.4	14.0	12.0
AY024MA322	AV36	17	–	800	24.0	17.5	14.0	12.0
AY030MA322	AV36	17	–	1000	29.2	21.4	14.0	12.0
1 PH 13 SEER AC WITH AHP								
AY012MA322	AHP18	17	–	430	14.5	9.5	13.0	11.0
AY018MA322	AHP18	17	–	650	18.0	13.1	13.0	11.0
	AHP24	17	–	655	18.0	13.1	13.0	11.0
AY024MA322	AHP30	17	–	830	24.0	17.5	13.0	11.0
AY030MA322	AHP30	17	–	1040	28.6	20.8	13.0	11.0
1 PH 13 SEER AC WITH F*FP								
AY018MA322	F*FP024H06	17	–	600	18.0	13.1	13.0	11.0
AY030MA322	F*FP040H06	21	–	1000	28.6	20.8	13.0	11.0

Rated in accordance with DOE test procedures (Federal Register 12-27-79 and 3-18-88) and ARI Standards 210.
Cooling MBH based on 80°F entering air temperature, 50% RH, and rated air flow.
EER (Energy Efficiency Ratio) is the total cooling output in BTU's at 95°F outdoor ambient divided by the total electric power in watt-hours at those conditions.
SEER (Seasonal Energy Efficiency Ratio) is the total cooling output in BTU's during a normal annual usage period for cooling divided by the total electric power input in watt-hours during the same period.

1. MC coils available with a factory installed horizontal drain pan. See price pages for specific model number.

Go to www.ari.org/ariDirectory for the latest additional matches.

COOLING CAPACITY - Upflow, Downflow & Horizontal Furnaces and Coils

UNIT MODEL	FURNACE**		COIL MODEL	COOLING				
	CFM RANGE (MIN.-MAX.)	W		RATED CFM	NET MBH		SEER ¹	EER
					TOTAL	SENS.		
AY012MA322	250	14,17	FC/MC/PC/UC18	400	14.5	9.5	13.0	11.0
	550	14	HC18	400	14.5	9.5	13.0	11.0
AY018MA322	450 750	14,17	FC/MC/PC/UC18	600	18.0	13.1	13.0	11.0
		14,17	FC/MC/PC/UC24	600	18.0	13.1	13.0	11.0
		14,17	FC/MC/PC/UC30	600	18.0	13.1	13.0	11.0
		14	HC18	600	18.0	13.1	13.0	11.0
AY024MA322	600 1000	17	FC/MC/PC35	800	24.0	17.5	13.0	11.0
		14,17,21	FC/MC/PC/UC36	800	24.0	17.5	13.0	11.0
		14	HC30	800	24.0	17.5	13.0	11.0
AY030MA322	800 1200	17,21	FC/MC/PC35	1000	28.6	20.8	13.0	11.0

1. Requires a 2FD06700224 Blower Time Delay unless a standard furnace is equipped with one.

** Refer to Quick Selection Chart for specific furnace match-up.

COOLING CAPACITY - With Variable Speed Furnaces

UNIT MODEL	VARIABLE SPEED FURNACE MODEL	COIL MODEL ¹	W	COOLING				
				RATED CFM	NET MBH		SEER	EER
					TOTAL	SENS.		
1 PH 13 SEER AC WITH VARIABLE SPEED FURNACES²								
AY018MA322	PV8*A12	FC/MC/PC18A	14	600	18.0	13.1	14.0	12.0
	PV9*A12	FC/MC/PC18A	14	600	18.0	13.1	14.0	12.0
	P(C,V)9*B12	FC/MC/PC18B	17	600	18.0	13.1	14.0	12.0
	PV8*A12	FC/MC/PC24A	14	600	18.0	13.1	14.0	12.0
	P(C,V)9*B12	FC/MC/PC24B	17	600	18.0	13.1	14.0	12.0
	PV9*A12	FC/MC/PC24A	14	600	18.0	13.1	14.0	12.0
	PV8*A12	FC/MC/PC30A	14	600	18.0	13.1	14.0	12.0
	P(C,V)9*B12	FC/MC/PC30B	17	600	18.0	13.1	14.0	12.0
	PV9*A12	FC/MC/PC30A	14	600	18.0	13.1	14.0	12.0
	PV8*A12	HC18	14	600	18.0	13.1	14.0	12.0
PV9*A12	HC18	14	600	18.0	13.1	14.0	12.0	
AY024MA322	PV8*A12	FC/MC/PC36A	14	800	24.0	17.5	14.0	12.0
	PV9*A12	FC/MC/PC36A	14	800	24.0	17.5	14.0	12.0
	P(C,V)9*B12	FC/MC/PC36B	17	800	24.0	17.5	14.0	12.0
	PV8*A12	HC30	14	800	24.0	17.5	14.0	12.0
	PV9*A12	HC30	14	800	24.0	17.5	14.0	12.0
AY030MA322	PV8*B16	FC/MC/PC35B	17	1000	28.6	20.8	14.0	12.0
	PV8*C16	FC/MC/PC35C	21	1000	28.6	20.8	14.0	12.0
	PV8*C20	FC/MC/PC35C	21	1000	28.6	20.8	14.0	12.0
	P(C,V)9*B12	FC/MC/PC35B	17	1000	28.6	20.8	13.5	11.0
	P(C,V)9*C16	FC/MC/PC35C	21	1000	28.6	20.8	13.5	11.0

1. MC coils available with a factory installed horizontal drain pan. See price pages for specific model number.

2. Variable speed furnaces have B.O.D (Blower on Delay) standard.

CONDENSER ONLY DATA

Model	Suct. T/P @ Compr.		Air Temp on Condenser					
			75° F		95° F		115° F	
			Temp.	PSIG	MBH	KW	MBH	KW
AY012MA322	35	61.5	12.69	0.97	9.87	1.17	5.61	1.33
	40	68.6	14.78	0.97	12.13	1.17	7.98	1.35
	45	76.1	16.99	0.97	14.53	1.17	10.49	1.38
	50	84.1	19.35	0.97	17.08	1.17	13.16	1.42
AY018MA322	35	61.5	19.75	1.13	16.62	1.33	13.02	1.63
	40	68.6	19.88	1.12	17.5	1.34	13.97	1.64
	45	76.1	20.02	1.11	18.43	1.35	14.98	1.65
	50	84.1	20.16	1.1	19.42	1.37	16.06	1.67
AY024MA322	35	61.5	20.35	1.43	14.61	1.63	7.46	1.88
	40	68.6	23.36	1.48	18.07	1.69	10.71	1.93
	45	76.1	26.54	1.53	21.71	1.76	14.14	1.99
	50	84.1	29.93	1.59	25.6	1.83	17.8	2.05
AY030MA322	35	61.5	20.62	1.74	17.48	1.92	11.16	2.22
	40	68.6	25.47	1.78	21.15	2	14.5	2.3
	45	76.1	30.59	1.82	25.02	2.08	18.02	2.38
	50	84.1	36.05	1.87	29.15	2.17	21.79	2.47

1. For condensing unit only. Does not include effect of evaporator motor power or heat.

2. Sub-cooling in excess of 20° may result in excessively high condensing temperature with air on condenser above 115° Maximum recommended condensing temperature is 140°F.

ACCESSORIES*

Refer to Price Manual for specific model numbers.

OFF CYCLE TIMER DELAY - Provides a 5-minute off cycle to prevent rapid recycling of the compressor.

ROOM THERMOSTATS - A wide selection of compatible thermostats are available to provide optimum performance and features for any installation.

1H/1C, manual changeover electronic non-programmable therm stat.

1H/1C, auto/manual changeover, electronic programmable, deluxe 7-day, thermostat.

1H/1C, auto/manual changeover, electronic programmable.

* For the most current accessory information, refer to the price book or consult factory.

SOUND POWER RATINGS*

UNIT MODEL	(dBA)
012	74
018	72
024	76
030	76

*Rated in accordance with ARI 270-95 Standards.

TYPICAL INSTALLATION

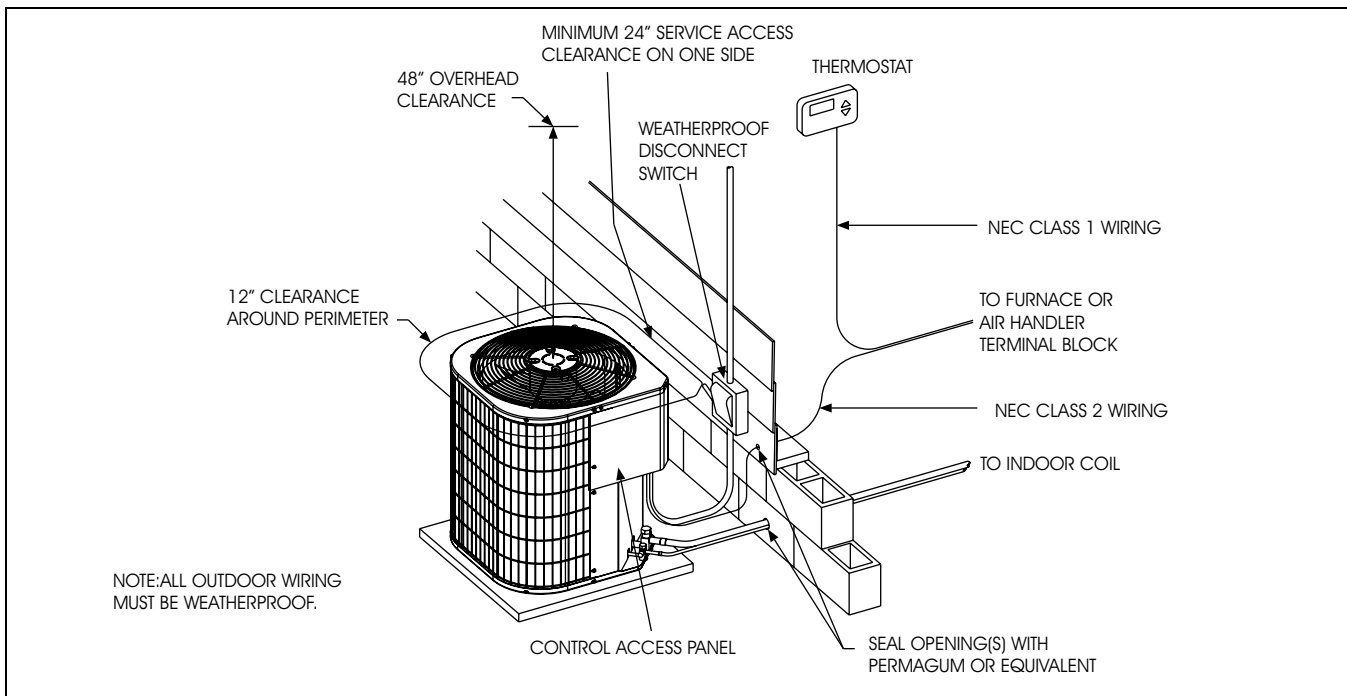

TYPICAL FIELD WIRING

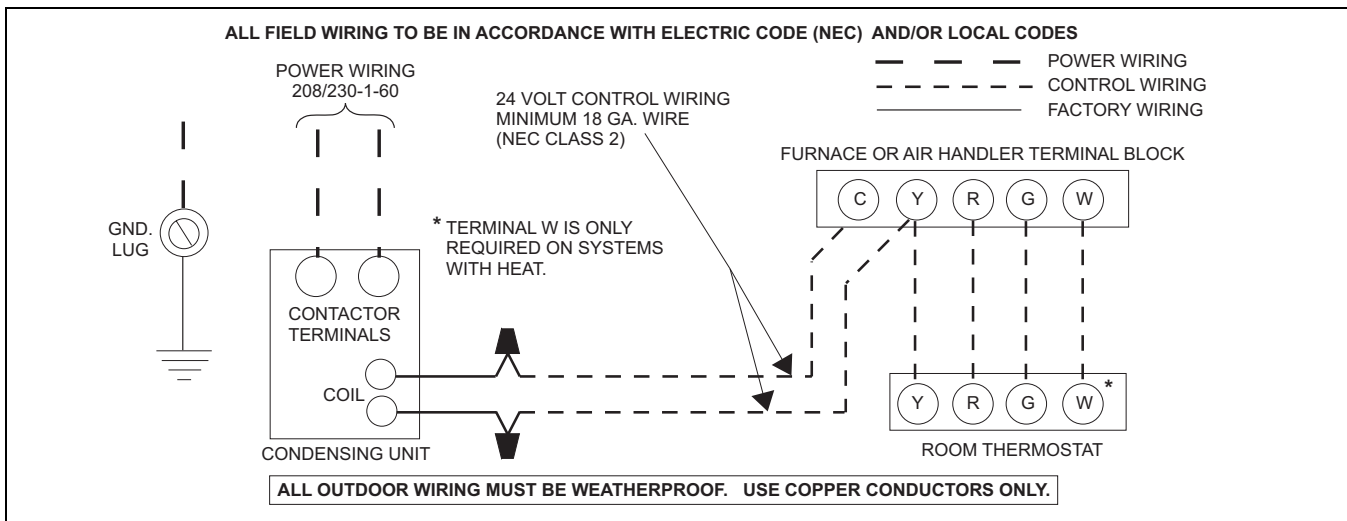

COOLING PERFORMANCE DATA																
AIR CONDITIONER MODEL NO.		AY012MA322														
INDOOR COIL MODEL NO.		FC/MC/PC/UC18														
CONDENSING ENTERING AIR TEMPERATURE	IDCFM	400					450					500				
	ID DB (°F)	80	80	75	80	80	80	80	75	80	80	80	80	75	80	80
	ID WB (°F)	57	62	62	67	72	57	62	62	67	72	57	62	62	67	72
65	T.C.	14.9	15.9	15.6	16.7	17.8	15.5	16.3	15.9	16.9	18.1	16.0	16.6	16.2	17.1	18.4
	S.C.	14.3	12.8	10.8	10.7	8.5	15.0	13.5	11.5	11.2	9.0	15.7	14.3	12.1	11.7	9.5
	KW	0.9	0.9	0.9	0.9	0.9	0.9	0.9	0.9	0.9	0.9	0.9	0.9	0.9	0.9	0.9
75	T.C.	14.2	15.2	15.0	16.2	17.5	14.8	15.6	15.3	16.5	17.9	15.5	16.0	15.7	16.8	18.2
	S.C.	13.8	12.5	10.6	10.5	8.4	14.5	13.4	11.2	11.1	8.9	15.2	14.2	11.9	11.6	9.4
	KW	1.0	1.0	1.0	1.0	1.0	1.0	1.0	1.0	1.0	1.0	1.0	1.0	1.0	1.0	1.0
85	T.C.	13.4	14.6	14.3	15.8	17.3	14.2	15.0	14.7	16.1	17.7	15.0	15.5	15.1	16.5	18.1
	S.C.	13.2	12.3	10.3	10.3	8.3	14.0	13.2	11.0	10.9	8.9	14.7	14.1	11.7	11.6	9.4
	KW	1.1	1.1	1.1	1.1	1.1	1.1	1.1	1.1	1.1	1.1	1.1	1.1	1.1	1.1	1.1
95	T.C.	12.7	13.9	13.7	15.4	17.1	13.6	14.4	14.2	15.8	17.5	14.5	14.9	14.6	16.2	17.9
	S.C.	12.7	12.1	10.1	10.1	8.3	13.5	13.1	10.8	10.8	8.8	14.3	14.0	11.6	11.5	9.3
	KW	1.2	1.2	1.2	1.2	1.2	1.2	1.2	1.2	1.2	1.2	1.2	1.2	1.2	1.2	1.2
105	T.C.	11.7	12.8	12.5	14.3	15.9	12.6	13.4	13.0	14.7	16.5	13.4	14.0	13.5	15.1	17.0
	S.C.	11.7	11.7	9.6	9.8	7.9	12.5	12.6	10.4	10.5	8.5	13.3	13.5	11.1	11.2	9.0
	KW	1.3	1.3	1.3	1.3	1.3	1.3	1.3	1.3	1.3	1.3	1.3	1.3	1.3	1.3	1.3
115	T.C.	10.8	11.8	11.4	13.3	14.8	11.6	12.5	11.9	13.7	15.5	12.5	13.1	12.3	14.0	16.1
	S.C.	10.7	11.2	9.1	9.5	7.6	11.5	12.1	9.9	10.2	8.1	12.3	13.0	10.7	10.9	8.7
	KW	1.4	1.4	1.4	1.4	1.5	1.4	1.4	1.4	1.4	1.5	1.4	1.4	1.4	1.4	1.5
125	T.C.	9.8	10.8	10.2	12.3	13.7	10.6	11.5	10.7	12.7	14.5	11.5	12.2	11.2	13.0	15.3
	S.C.	9.8	10.8	8.7	9.1	7.3	10.6	11.6	9.5	9.8	7.8	11.4	12.4	10.3	10.6	8.4
	KW	1.5	1.5	1.5	1.6	1.6	1.5	1.5	1.5	1.6	1.6	1.6	1.6	1.5	1.6	1.6

NOTE: ALL CAPACITIES INCLUDE INDOOR FAN HEAT AT 1250 BTUH/1000 CFM.

Multipliers for determining the performance with other indoor sections.

NOTE: For dry bulb temperatures different than those listed (between 73-87 F), sensible capacity increases by 1060 BTUH per 1000 CFM per degree above the listed temperature and decreases by 1060 BTUH per 1000 CFM per degree below the listed temperature.

Air Handler	Coil	T.C.	S.C.	KW
AHP18	–	1.00	1.00	1.00
F*FP024	–	1.00	1.00	1.00
–	HC18	1.00	1.00	1.00

COOLING PERFORMANCE DATA																
AIR CONDITIONER MODEL NO.		AY018MA322														
INDOOR COIL MODEL NO.		FC/MC/PC/UC18														
CONDENSER ENTERING AIR TEMPERATURE	ID CFM	450					600					750				
	ID DB (°F)	80	80	75	80	80	80	80	75	80	80	80	80	75	80	80
	ID WB (°F)	57	62	62	67	72	57	62	62	67	72	57	62	62	67	72
65	T.C.	17.5	19.4	18.9	20.9	22.3	18.3	19.7	19.4	20.9	21.8	19.0	20.0	19.8	20.9	21.3
	S.C.	17.2	15.3	12.8	12.7	10.1	18.2	17.3	14.1	13.6	10.7	19.2	19.3	15.4	14.4	11.3
	KW	1.0	1.0	1.0	1.0	1.0	1.0	1.0	1.0	1.0	1.0	1.0	1.0	1.0	1.0	1.0
75	T.C.	16.8	18.4	18.0	19.9	21.6	17.6	18.8	18.5	20.0	21.3	18.5	19.2	18.9	20.1	21.0
	S.C.	16.5	14.8	12.4	12.3	9.9	17.5	16.8	13.9	13.4	10.5	18.6	18.8	15.3	14.4	11.2
	KW	1.1	1.1	1.1	1.1	1.1	1.1	1.1	1.1	1.1	1.1	1.1	1.1	1.1	1.1	1.1
85	T.C.	16.0	17.3	17.1	19.0	20.8	17.0	17.9	17.6	19.1	20.8	18.0	18.5	18.1	19.3	20.7
	S.C.	15.7	14.4	12.0	11.9	9.6	16.9	16.4	13.6	13.2	10.3	18.1	18.4	15.3	14.4	11.0
	KW	1.2	1.2	1.2	1.2	1.2	1.2	1.2	1.2	1.2	1.2	1.2	1.2	1.2	1.2	1.2
95	T.C.	15.3	16.2	16.2	18.1	20.1	16.4	17.0	16.7	18.3	20.2	17.5	17.7	17.2	18.4	20.4
	S.C.	14.9	13.9	11.6	11.5	9.4	16.2	16.0	13.4	13.0	10.1	17.5	18.0	15.2	14.4	10.9
	KW	1.3	1.3	1.3	1.4	1.4	1.4	1.4	1.4	1.4	1.4	1.4	1.4	1.4	1.4	1.4
105	T.C.	14.4	14.9	14.8	16.7	18.8	15.4	15.7	15.3	16.9	18.9	16.4	16.5	15.8	17.1	19.0
	S.C.	14.0	13.3	11.0	11.0	9.0	15.2	15.2	12.8	12.5	9.8	16.4	17.0	14.5	14.0	10.6
	KW	1.5	1.5	1.5	1.5	1.5	1.5	1.5	1.5	1.5	1.5	1.5	1.5	1.5	1.5	1.5
115	T.C.	13.4	13.6	13.4	15.4	17.6	14.4	14.5	13.9	15.6	17.7	15.4	15.4	14.5	15.8	17.7
	S.C.	13.1	12.8	10.5	10.5	8.5	14.2	14.4	12.2	12.1	9.4	15.3	16.0	13.9	13.7	10.2
	KW	1.7	1.7	1.7	1.7	1.7	1.7	1.7	1.7	1.7	1.7	1.7	1.7	1.7	1.7	1.7
125	T.C.	12.5	12.3	12.0	14.0	16.4	13.4	13.3	12.6	14.3	16.4	14.3	14.3	13.1	14.5	16.4
	S.C.	12.3	12.3	9.9	10.0	8.1	13.2	13.6	11.6	11.7	9.0	14.2	14.9	13.2	13.4	9.9
	KW	1.8	1.8	1.8	1.8	1.8	1.8	1.8	1.8	1.8	1.8	1.8	1.8	1.8	1.8	1.9

NOTE: ALL CAPACITIES INCLUDE INDOOR FAN HEAT AT 1250 BTUH/1000 CFM.

Multipliers for determining the performance with other indoor sections.

NOTE: For dry bulb temperatures different than those listed (between 73-87 F), sensible capacity increases by 1060 BTUH per 1000 CFM per degree above the listed temperature and decreases by 1060 BTUH per 1000 CFM per degree below the listed temperature.

Air Handler	Coil	T.C.	S.C.	KW
MA08	FC/MC/UC18B	1.00	1.00	1.00
MV12B	FC/MC/UC18B	1.02	1.02	0.92
AV24	-	1.02	1.02	0.92
AHP18	-	1.00	1.00	1.00
AHP24	-	1.00	1.00	1.00
F*FP024H06	-	1.00	1.00	1.00
-	FC/MC/PC/UC24	1.00	1.00	1.00
-	FC/MC/PC/UC30	1.00	1.00	1.00
-	HC18	1.00	1.00	1.00

Variable Speed Furnace	Coil	T.C.	S.C.	KW
PV8*A12	FC/MC/PC18A	1.02	1.02	0.92
PV9*A12	FC/MC/PC18A	1.02	1.02	0.92
P(C,V)9*B12	FC/MC/PC18B	1.02	1.02	0.92
PV8*A12	FC/MC/PC24A	1.02	1.02	0.92
P(C,V)9*B12	FC/MC/PC24B	1.02	1.02	0.92
PV9*A12	FC/MC/PC24A	1.01	1.01	0.92
PV8*A12	FC/MC/PC30A	1.02	1.02	0.92
P(C,V)9*B12	FC/MC/PC30B	1.02	1.02	0.92
PV9*A12	FC/MC/PC30A	1.01	1.01	0.92
PV8*A12	HC18	1.02	1.02	0.92
PV9*A12	HC18	1.02	1.02	0.92

COOLING PERFORMANCE DATA																
AIR CONDITIONER MODEL NO.		AY024MA322														
INDOOR COIL MODEL NO.		FC/MC/PC/UC36														
CONDENSER ENTERING AIR TEMPERATURE	ID CFM	600					800					1000				
	ID DB (°F)	80	80	75	80	80	80	80	75	80	80	80	80	75	80	80
	ID WB (°F)	57	62	62	67	72	57	62	62	67	72	57	62	62	67	72
65	T.C.	20.7	23.8	24.5	26.2	27.0	22.1	25.2	25.5	26.9	27.6	23.4	26.7	26.4	27.7	28.2
	S.C.	20.1	17.5	15.7	15.5	11.5	21.5	19.7	17.7	16.7	12.1	23.0	21.8	19.7	17.9	12.6
	KW	1.3	1.4	1.4	1.4	1.4	1.3	1.4	1.4	1.4	1.4	1.4	1.4	1.4	1.4	1.4
75	T.C.	19.5	22.5	23.1	25.1	26.7	21.1	23.9	24.1	26.0	27.3	22.6	25.3	25.0	26.9	27.8
	S.C.	18.9	17.3	15.2	15.1	11.4	20.5	19.7	17.4	16.7	12.2	22.1	22.1	19.6	18.3	13.0
	KW	1.5	1.5	1.5	1.5	1.5	1.5	1.5	1.5	1.5	1.5	1.5	1.5	1.5	1.5	1.6
85	T.C.	18.4	21.2	21.7	24.1	26.4	20.1	22.6	22.7	25.1	26.9	21.8	24.0	23.7	26.1	27.4
	S.C.	17.8	17.0	14.7	14.7	11.3	19.6	19.7	17.1	16.7	12.3	21.3	22.4	19.4	18.8	13.3
	KW	1.6	1.6	1.6	1.7	1.7	1.6	1.6	1.6	1.7	1.7	1.7	1.7	1.7	1.7	1.7
95	T.C.	17.2	19.9	20.2	23.0	26.1	19.1	21.3	21.2	24.2	26.6	21.0	22.6	22.3	25.3	27.0
	S.C.	16.7	16.8	14.2	14.3	11.3	18.6	19.7	16.7	16.8	12.5	20.5	22.7	19.3	19.2	13.7
	KW	1.7	1.8	1.8	1.8	1.9	1.8	1.8	1.8	1.8	1.9	1.8	1.8	1.8	1.9	1.9
105	T.C.	15.8	17.9	18.1	20.7	24.0	17.6	19.5	19.1	21.7	24.6	19.3	21.0	20.0	22.8	25.2
	S.C.	15.3	15.8	13.4	13.4	10.6	17.1	18.4	15.8	15.8	11.9	18.9	21.0	18.2	18.2	13.2
	KW	1.9	1.9	1.9	1.9	2.0	1.9	1.9	1.9	2.0	2.0	2.0	2.0	1.9	2.0	2.0
115	T.C.	14.5	16.1	16.0	18.4	22.0	16.1	17.7	17.0	19.4	22.7	17.7	19.4	17.9	20.3	23.4
	S.C.	14.0	15.0	12.5	12.4	10.0	15.6	17.2	14.9	14.8	11.3	17.3	19.4	17.2	17.2	12.7
	KW	2.0	2.0	2.0	2.1	2.1	2.1	2.1	2.0	2.1	2.2	2.1	2.1	2.1	2.1	2.2
125	T.C.	13.1	14.2	14.0	16.2	20.0	14.6	16.0	14.8	17.0	20.8	16.1	17.8	15.7	17.8	21.7
	S.C.	12.7	14.1	11.7	11.5	9.3	14.2	15.9	14.0	13.9	10.8	15.7	17.7	16.2	16.2	12.3
	KW	2.2	2.2	2.1	2.2	2.3	2.2	2.2	2.2	2.2	2.3	2.3	2.3	2.2	2.3	2.4

NOTE: ALL CAPACITIES INCLUDE INDOOR FAN HEAT AT 1250 BTUH/1000 CFM.

Multipliers for determining the performance with other indoor sections.

NOTE: For dry bulb temperatures different than those listed (between 73-87 F), sensible capacity increases by 1060 BTUH per 1000 CFM per degree above the listed temperature and decreases by 1060 BTUH per 1000 CFM per degree below the listed temperature.

Air Handler	Coil	T.C.	S.C.	KW
MA08	FC/MC/UC36B	1.00	1.00	1.00
MV12B	FC/MC35B	1.00	1.03	0.91
MV12B	FC/MC/UC36B	1.02	1.02	0.92
AV36	–	1.00	1.03	0.91
AHP30	–	1.00	1.00	1.00
–	FC/MC/PC35	1.00	1.00	1.00
–	HC30	1.00	1.00	1.00

Variable Speed Furnace	Coil	T.C.	S.C.	KW
PV8*A12	FC/MC/PC/UC36A	1.02	1.02	0.96
PV9*A12	FC/MC/PC/UC36A	1.02	1.02	0.96
P(C,V)9*B12	FC/MC/PC/UC36B	1.02	1.02	0.96
PV8*A12	HC30	1.02	1.02	0.96
PV9*A12	HC30	1.02	1.02	0.96

COOLING PERFORMANCE DATA																
AIR CONDITIONER MODEL NO.		AY030MA322														
INDOOR COIL MODEL NO.		FC/MC/PC35														
CONDENSER ENTERING AIR TEMPERATUR	ID CFM	800					1000					1200				
	ID DB (°F)	80	80	75	80	80	80	80	75	80	80	80	80	75	80	80
	ID WB (°F)	57	62	62	67	72	57	62	62	67	72	57	62	62	67	72
65	T.C.	29.5	31.7	31.0	34.2	36.5	28.6	31.0	30.3	33.0	35.2	27.6	30.3	29.6	31.8	34.0
	S.C.	29.2	28.4	23.9	22.5	16.8	28.3	26.5	22.2	21.0	15.6	27.4	24.6	20.4	19.4	14.5
	KW	1.6	1.6	1.7	1.7	1.7	1.6	1.6	1.7	1.7	1.7	1.6	1.6	1.6	1.7	1.7
75	T.C.	28.7	30.8	29.6	33.1	35.4	27.4	29.7	28.7	31.9	34.2	26.1	28.6	27.9	30.7	33.1
	S.C.	28.4	28.2	23.7	22.8	16.9	27.1	26.1	21.8	21.1	15.7	25.9	24.1	19.8	19.3	14.5
	KW	1.8	1.8	1.8	1.8	1.9	1.8	1.8	1.8	1.8	1.9	1.8	1.8	1.8	1.8	1.9
85	T.C.	27.9	30.0	28.2	32.0	34.2	26.3	28.5	27.2	30.8	33.3	24.7	27.0	26.1	29.6	32.3
	S.C.	27.5	27.9	23.5	23.2	16.9	26.0	25.8	21.3	21.1	15.7	24.4	23.6	19.2	19.1	14.4
	KW	2.0	2.0	2.0	2.0	2.1	2.0	2.0	2.0	2.0	2.1	2.0	2.0	2.0	2.0	2.0
95	T.C.	27.1	29.1	26.8	30.9	33.1	25.1	27.2	25.6	29.7	32.3	23.2	25.4	24.4	28.5	31.5
	S.C.	26.7	27.7	23.3	23.5	17.0	24.8	25.4	20.9	21.2	15.7	22.9	23.1	18.5	19.0	14.4
	KW	2.2	2.2	2.2	2.2	2.3	2.2	2.2	2.2	2.2	2.3	2.1	2.1	2.1	2.2	2.2
105	T.C.	25.4	26.9	24.5	28.4	30.7	23.5	25.2	23.4	27.2	29.8	21.5	23.5	22.2	26.0	28.9
	S.C.	24.7	25.6	21.7	22.6	16.3	23.0	23.6	19.6	20.3	14.9	21.3	21.6	17.5	18.0	13.5
	KW	2.4	2.4	2.4	2.4	2.5	2.4	2.4	2.3	2.4	2.4	2.3	2.3	2.3	2.4	2.4
115	T.C.	23.8	24.8	22.3	25.9	28.3	21.9	23.2	21.2	24.8	27.4	19.9	21.7	20.1	23.6	26.5
	S.C.	22.8	23.5	20.2	21.7	15.7	21.2	21.8	18.4	19.4	14.2	19.7	20.1	16.6	17.1	12.7
	KW	2.6	2.6	2.5	2.6	2.7	2.5	2.5	2.5	2.6	2.6	2.5	2.5	2.5	2.6	2.6
125	T.C.	22.2	22.6	20.1	23.4	26.0	20.3	21.2	19.0	22.3	25.0	18.4	19.8	17.9	21.2	24.0
	S.C.	20.8	21.4	18.6	20.7	15.0	19.5	20.1	17.1	18.5	13.4	18.1	18.7	15.7	16.2	11.8
	KW	2.8	2.8	2.7	2.8	2.8	2.7	2.7	2.7	2.8	2.8	2.7	2.7	2.6	2.7	2.8

NOTE: ALL CAPACITIES INCLUDE INDOOR FAN HEAT AT 1250 BTUH/1000 CFM.

Multipliers for determining the performance with other indoor sections.

NOTE: For dry bulb temperatures different than those listed (between 73-87 F), sensible capacity increases by 1060 BTUH per 1000 CFM per degree above the listed temperature and decreases by 1060 BTUH per 1000 CFM per degree below the listed temperature.

Air Handler	Coil	T.C.	S.C.	KW
MA12B	FC/MC/PC35B	1.00	1.00	1.00
MV12B	FC/MC/PC35B	1.02	1.02	0.92
MV16C	FC/MC/PC35B	1.02	1.02	0.92
AV36	—	1.02	1.02	0.92
AHP30	—	1.00	1.00	1.00
F*FP040H06	—	1.00	1.00	1.00

Variable Speed Furnace	Coil	T.C.	S.C.	KW
PV8*B16	FC/MC/PC35B	1.01	1.01	0.92
PV8*C16	FC/MC/PC35C	1.01	1.01	0.92
PV8*C20	FC/MC/PC35C	1.01	1.01	0.92
P(C,V)9*B12	FC/MC/PC35B	1.01	1.01	0.96
P(C,V)9*C16	FC/MC/PC35C	1.01	1.01	0.96

NOTES

NOTES